



MOKTRANS



SRC HELICAL
GEAR REDUCER



SRC GEARBOX
WITH AC MOTOR



TWO GEAR-STEP
REDUCTION



THREE GEAR-STEP
REDUCTION

目录
CONTENTS

Page		
1	技术特征	TECHNICAL FEATURES
2	产品结构图	PRODUCT STRUCTURE PICTURE
3	型号说明	MODEL ILLUMINATE
4-7	选型相关参数	RELEVANT PARAMETER
8	选型举例	SELECTION EXAMPLE
9	速比与IEC接口	RATIO AND IEC MOTOR ADAPTERS
10-20	减速器选型表	SELECTION TABLES
21-28	外形尺寸图表	OUTLINE DIMENSION SHEET
29	安装方位	INSTALLATION POSITIONS
29	润滑油	LUBRICATION
	系列产品展示	SHOW THE SERIES PRODUCTS

1. 技术特征

SRC斜齿轮减速器具有高度模块化的设计特点。可分别与普通IEC、制动、防爆、变频、伺服等电机组合。本产品广泛用于纺织、食品、陶瓷、包装、物流、塑料等传动领域，可选用不同的法兰和底脚组建各种减速器的结构。

1.1 产品特点

SRC系列小型斜齿轮减速器共有4种机型号，功率0.12~4KW，速比3.66~54，最大扭矩120~500Nm。可根据用户要求进行任意组合(底脚、法兰)和多种安装位置的选择。

- 使用磨削硬齿面斜齿轮；
- 模块化，可组合多种结构形式；
- 铝制箱体，重量轻；
- 渗碳硬齿面，经久耐用；
- 安装方式多样；
- 设计精巧，结构紧凑，噪音小。

1. TECHNICAL FEATURES

The high degree of modularity is a design feature of SRC helical gearboxes range. It can be connected respectively with motors such as normal motor, brake motor, explosion-proof motor, frequency conversion motor, servo motor, IEC motor and so on. This kind of product is widely used in drive fields such as textile, foodstuff, ceramics packing, logistics , plastics and so on. It is possible to set up the version required using flanges or feet.

1.1 Products characteristics

SRC Series helical gear units has more than 4 types. Power 0.12-4KW; Ratio 3.66- 54; Torque max 120-500Nm. It can be connected (foot or flange) discretionary and use multi-mounting positions accordng to custom- ers' requirements.

- Ground-hardened helical gears;
- Modularity, Can be combined in many forms;
- Aluminium casing, light weight;
- Gears in carbonize hard,durable;
- Universal mounting;
- Refined design, space effective and low noise.

1.2 结构特点 / Structure feature

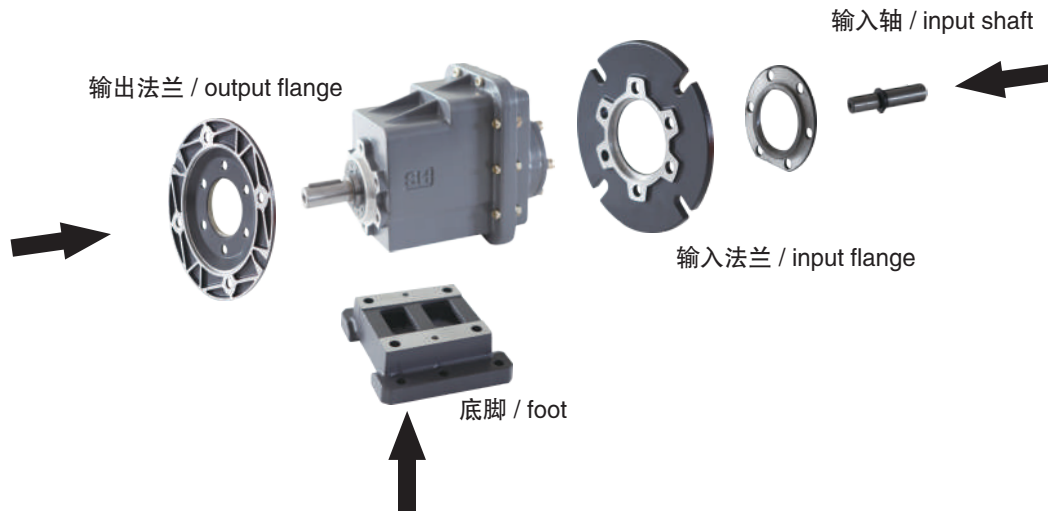

2. 产品结构 / PRODUCT STRUCTURE PICTURE



SRC..P(IEC)
底脚安装斜齿轮减速器
Foot-mounted helical gear unit



SRC..HS
轴输入底脚安装斜齿轮减速器
Shaft input foot-mounted helical gear unit



SRCZ..P(IEC)
B14形式法兰安装斜齿轮减速器
B14 Flange-mounted helical gear unit



SRCZ..HS
轴输入B14形式法兰安装斜齿轮减速器
Shaft input B14 Flange-mounted helical gear unit



SRCF..P(IEC)
法兰安装斜齿轮减速器
Flange-mounted helical gear unit



SRCF..HS
轴输入法兰安装斜齿轮减速器
Shaft input Flange-mounted helical gear unit

3. 型号说明 / MODEL ILLUMINATE

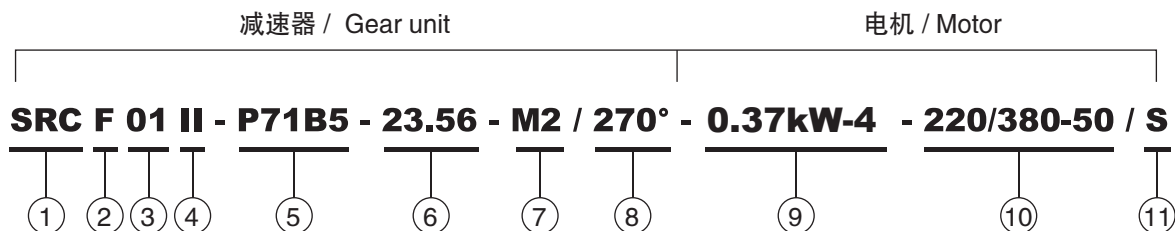

① SRC: 减速器系列代号	SRC: code for gear units series
1). 无代号表示底脚安装 ② 2). F: B5形式法兰安装 3). Z: B14形式法兰安装	1). No code means foot-mounted 2). F: B5 flange mounted 3). Z: B14 flange mounted
③ 减速器规格号 01、02、03、04	Specification code of gear units 01,02,03,04
④ 1). B01、M01.....表示底脚代号, 无法兰 2). I、II、III: B5形式输出法兰规格, 默认I可以不写	1). B01、M01.....means foot code,without flange 2). I, II, III. B5 Output flange specification, default I not to write out is ok
⑤ 1). IEC输入法兰 2). HS: 轴输入	1). IEC input flange 2). HS: Shaft input
⑥ 减速器传动比 (i)	Transmission ratio of gear units (i)
⑦ M1: 安装方位, 默认安装方位M1可以不写	M1: Mounting positio, default mounting position M1 not to write out is ok
⑧ 电机接线盒位置, 默认位置0° (R)可以不写	Position diagram for motor terminal box, default position 0°(R) not to write out is ok
⑨ 1). 无代号表示不带电机 2). 电机型号或功率、极数	1). No mark means without motor 2). Model motos (poles of power)
⑩ 电压-频率	Voltage - frequency
⑪ 电机进线位置, 默认位置S可以不写	Coil in pssition for motor, default position S not to write out is ok

示例 **Example** : SRC01B01 - P71 B5 - 23.56

SRCZ03 - HS - 6.31

SRCF02III - P80B14 - 8.78 - 0.75kW-4 - 220/380 - 50 / E

订单时请说明是否带电机, 一般按不带电机供应。

When ordering, you should show whether the reducers are equipped with motors, otherwise reducers aren't supplied with motors.

4. 选型相关参数

4.1 功率 P

$$P_1 = \frac{P_2}{\eta} \text{ [KW]}$$

$$P_{1n} \geq P_1 \cdot f_s \text{ [KW]}$$

P_1	输入功率
P_2	输出功率
P_{1n}	输入电机额定功率
f_s	使用系数
η	传动效率

SRC系列斜齿轮减速器的传动是2级齿轮传动，其效率 η 为96%。

4.2 转速 n

n_1	减速器输入转速
n_2	减速器输出转速

若是齿轮箱外部传动装置驱动，为了优化工作条件和提高使用寿命，建议使用1400r/min或更低转速。允许输入较高的输入转速，但在这种情况下，额定扭矩 M_2 会下降。

4.3 传动比 i

$$i = \frac{n_1}{n_2}$$

传动比通常为小数，在选型表中保留两位小数。

4.4 扭矩 M

$$M_2 = \frac{9550 \cdot P_1 \cdot \eta}{n_2} \text{ [Nm]}$$

$$M_{2n} \geq M_2 \cdot f_s \text{ [Nm]}$$

M_2	输出扭矩
M_{2n}	额定输出扭矩
P_1	输入功率
η	传动效率
f_s	使用系数

4. RELEVANT PARAMETER

4.1 Power P

$$P_1 = \frac{P_2}{\eta} \text{ [KW]}$$

$$P_{1n} \geq P_1 \cdot f_s \text{ [KW]}$$

P_1	Input power
P_2	Output power
P_{1n}	Rated input motor power
f_s	Service factor
η	Transmission efficiency

SRC Series helical gear units has 2 stage and the efficiency is about 96%.

4.2 Rotation speed n

n_1	Gear units input speed
n_2	Gear units output speed

If driven by the external gearing, 1400r/min or lower rotation speed is suggested so as to optimize the working conditions and prolong the service life. Higher input rotation speed is permitted, but in this situation, the rated torque M_2 will be reduced.

4.3 Transmission ratio i

$$i = \frac{n_1}{n_2}$$

Usually transmission ratio is decimal fraction with 2 radix point tagged in selection tables.

4.4 Torque M

$$M_2 = \frac{9550 \cdot P_1 \cdot \eta}{n_2} \text{ [Nm]}$$

$$M_{2n} \geq M_2 \cdot f_s \text{ [Nm]}$$

M_2	Output torque
M_{2n}	Rated output torque
P_1	Input power
η	Transmission efficiency
f_s	Service factor

4.5 使用系数 f_s

使用减速器时，应考虑一定的使用系数 f_s ，它是根据每天的运转时间和启动频率 Z 确定的。根据惯性加速系数确定三种负载类型，在下图中可以读取实际应用的使用系数，按下图选取的使用系数必须小于或等于从性能参数表中提供的使用系数。

4.5 Service factor f_s

The effect of the driven machine on the gear unit is taken into account to a sufficient level of accuracy using the service factor f_s . The service factor is determined according to the daily operating time and the starting frequency Z . Three load classifications are considered depending on the mass acceleration factor. You can read off the service factor applicable to your application in following Figure. The service factor selected using this diagram must be less than or equal to the service factor as given in the performance parameter table.

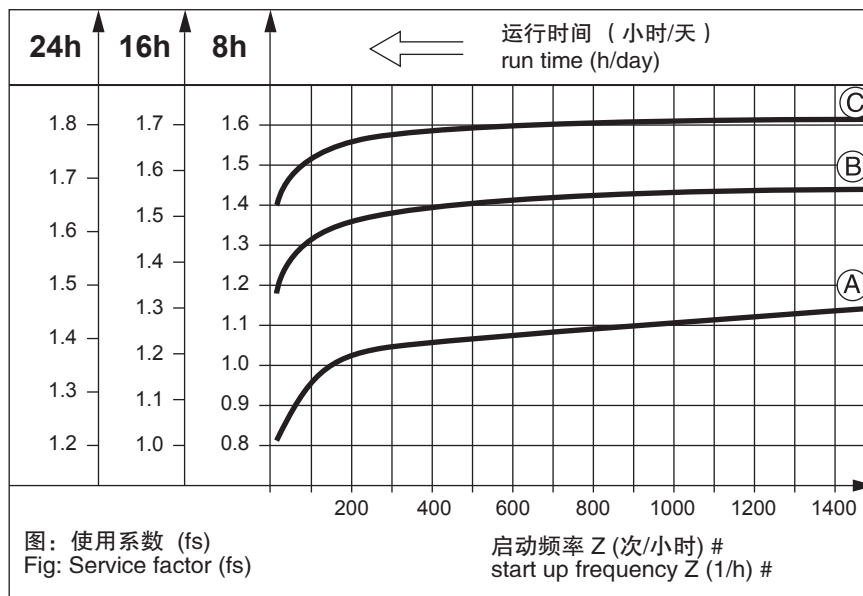

启动频率 Z : 周期包括所有启动、制动的次数以及变速电机高低速变化时的次数。

Starting frequency Z : The cycles include all starting and braking procedures as well as change overs from low to high speed.

4.5.1 负载类型

- (A) 均匀冲击负载，允许惯性加速系数 ≤ 0.2
- (B) 中等冲击负载，允许惯性加速系数 ≤ 3
- (C) 重冲击负载，允许惯性加速系数 ≤ 10

负载类型见附录。

4.5.1 Load classifications

- (A) Uniform shock load, permitted mass acceleration factor ≤ 0.2
- (B) Moderate shock load, permitted mass acceleration factor ≤ 3
- (C) Heavy shock load, permitted mass acceleration factor ≤ 10

Load classifications see the addendum.

4.5.2 惯性加速系数

惯性加速系数计算如下:

$$f_a = \frac{J_c}{J_m}$$

4.5.2 Mass acceleration factor

The mass acceleration factor is calculated as follows:

$$f_a = \frac{J_c}{J_m}$$

选型相关参数

RELEVANT PARAMETER

fa 惯性加速系数

Jc 所有外部传动惯量 [kgm²]

Jm 驱动电机的传动惯量 [kgm²]

如果惯性加速系数 $fa > 10$ ，请与我们联系。

为了保持减速器的使用寿命，从产品样本中的性能参数表所选择的使用系数 fs 应等于或略高于计算出的使用系数 fs 。

4.6 径向载荷 F_r

在确定影响径向载荷时，安装在轴端上的传动件类型必须考虑在内，不同类型的传动件对应不同传动附加系数 f_z ，列表如下：

传动件 Transmission element	传动附加系数 F_z Transmission element factor F_z	注释 Comments
齿轮 Gears	1.00	≥ 17 齿 teech
	1.15	< 17 齿 teech
链轮 Chain sprockets	1.00	≥ 20 齿 teech
	1.25	< 20 齿 teech
	1.40	< 13 齿 teech
V带轮 Narrow V-belt pulleys	1.75	有预紧力作用 Influence of the tensile force
平带轮 Flat belt pulleys	2.50	有预紧力作用 Influence of the tensile force
齿带轮 Toothed beld pulleys	2.50	有预紧力作用 Influence of the tensile force

作用在轴上的径向载荷按如下公式计算：

$$F_r = \frac{M \cdot 2000 \cdot f_z}{d_0} \text{ [N]}$$

F_r 作用在轴上的载荷 [N]

M 作用在轴上的扭矩 [Nm]

d_0 安装在轴上传动件的平均直径 [mm]

f_z 传动附加系数

当径向负荷不作用在轴中点时，按以下公式计算有效负荷：

$$F_{xL} \leq \frac{F_{r2} \cdot a}{(b+x)} \text{ [N]}$$

F_{r2} 依据下面表格给出中底脚安装式齿轮减速器的许可径向载荷 ($x = L/12$) [N]

a, b 减速器径向转换换算常量 [mm]

fa Mass acceleratio

Jc All external mass moments of inertia [kgm²]

Jm Mass moment of inertia on the motor end [kgm²]

If mass acceleration factors $fa > 10$, please call our Technical Service.

To keep the service-life of gear units, the use factor **fs** selected from the catalogue must lbe equal or slightly higher than the calculated use factor **fs**.

4.6 Radial loads F_r

When determining. the resulting radial loads, the type of transmission elements, mounted on the shaft end must be considered. Various transmission elements are corresponding with following transmiss-ion element factors f_z :

The radial loads exerted on the motor or gear shaft is then calculated as follows:

$$F_r = \frac{M \cdot 2000 \cdot f_z}{d_0} \text{ [N]}$$

F_r Resulting radial load [N]

M Torque on the shaft [Nm]

d_0 Mean diameter of the mounted transmiss-ion element in [mm]

f_z Transmission element factor

The allowed radial load force on the shaft is calculated with the following formula:

$$F_{xL} \leq \frac{F_{r2} \cdot a}{(b+x)} \text{ [N]}$$

F_{r2} Permitted overhung load ($x=L/2$) for foot-mounted gear units according to the selection tables in [N]

a, b Gear unit constant for overhung load conversion [mm]

选型相关参数

RELEVANT PARAMETER

x 轴肩到实际作用点的距离[mm]

x Distance from the force application point in [mm]

a, b, Fr₂的数值在下面表格给出:

The values of a, b, Fr₂ are given in the following tables:

	SRC01	SRC02	SRC03	SRC04
a	103	116.5	130	147
b	83	91.5	100	112

输出轴径向载荷和轴向载荷 Fr₂, Fa / Output shafts radial loads & axial loads Fr₂, Fa

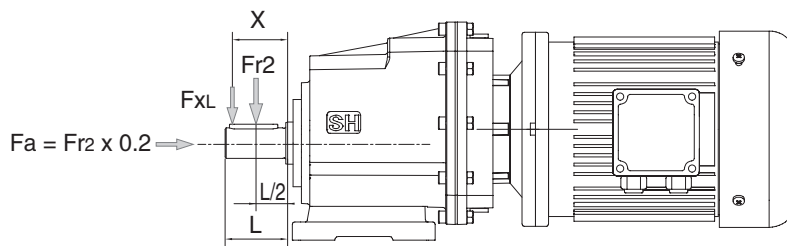

n ₂ [min ⁻¹]		10	40	60	80	100	120	150	180	250	400
Fr ₂ [N]	SRC01	2500	2500	2180	1980	1840	1630	1400	1320	1080	920
	SRC02	5000	5000	4370	3970	3680	3470	2710	2550	2150	1840
	SRC03	6500	6500	5550	5040	4510	3800	3530	3320	2800	2390
	SRC04	8000	8000	6590	5990	5230	4570	4240	3900	3350	2860

4.7 选型表注释 / SELECTION TABLES COMMENTS

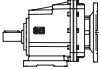
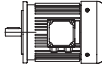
P _{1n} [KW]	n ₂ [r/min]	M _{2n} [Nm]	i	f _s			Page
----------------------	------------------------	----------------------	---	----------------	--	---	------

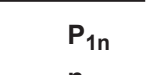
 表示IEC与减速器的组合是可行的
 表示IEC与减速器的组合是不可行的

P_{1n} 输入电机额定功率[kW];

n₂ 输出转速[r/min];

M_{2n} 额定输出扭矩[Nm];

M_{2 max} 最大允许输出扭矩[Nm];

i 减速器传动比;

f_s 使用系数;

 减速器型号;

 电机型号;

page 外型尺寸表页码;

* 表示速比可除尽。

 — Combination with the IEC in the header row is possible

 — Combination with the IEC in the header row is not possible

P_{1n} Rated power driving motor [kW];

n₂ Output speed [r/min];

M_{2n} Rated output torque [Nm]

M_{2 max} Permissible output torque [Nm];

i Gear unit ratio;

f_s Service factor;

 Gear unit type;

 Motor type;

page Dimension sheet page no;

* Finite gear unit reduction ratio.

5. 选型举例 / SELECTION EXAMPLE

5.1 减速器

例: 被驱动设备所需扭矩为200Nm, 工作6小时/天, 均匀冲击负载, 启动频率200次/小时, 输出转速 $n_2=50$ r/min, 要求减速器 Φ 160 mm输出法兰安装。

查表, 选使用系数 $f_s=1.02$

$$M_{2n} \geq M_2 \cdot f_s = 200 \times 1.02 = 204[\text{Nm}]$$

$$i = \frac{n_1}{n_2} = \frac{1400}{50} = 28$$

查SRC系列选型表可选定减速器为:

SRCF03 I - P90B5 - 30.57

5.2 减速电机

例: 被驱动设备所需功率0.75kW, 工作8小时/天, 中等冲击, 连续启动, 输出转速 $n_2=60$ r/min, 减速电机要求M2底脚安装。

查表, 选使用系数 $f_s=1.35$

$$i = \frac{n_1}{n_2} = \frac{1400}{60} = 23.33$$

$$P_{1n} \geq P_1 \cdot f_s = \frac{P_2}{\eta} \cdot f_s = \frac{0.75}{0.96} \times 1.35 = 1.05[\text{kW}]$$

查SRC系列选型表可选定减速电机型号为:

SRC02 - P90B5 - 23.85 - 1.1kW-4 - M2

5.1 Gear units

Example: The required torque on driven machine is 200Nm, works for 6 hours per day, Uniform shock load, start-up frequency is 200 times per hour, Φ 160mm output flange-mounted, $n_2=50$ r/min.

see tables, $f_s=1.02$

$$M_{2n} \geq M_2 \cdot f_s = 200 \times 1.02 = 204[\text{Nm}]$$

$$i = \frac{n_1}{n_2} = \frac{1400}{50} = 28$$

Choose type:

SRCF03 I - P90B5 - 30.57

5.2 gear motor

Example: The required power on driven machine 0.75kW, works for 8 hours per day, moderate shock load, start-up continuously, M2 foot-mounted, $n_2=60$ r/min.

see tables, $f_s=1.35$

$$i = \frac{n_1}{n_2} = \frac{1400}{60} = 23.33$$

$$P_{1n} \geq P_1 \cdot f_s = \frac{P_2}{\eta} \cdot f_s = \frac{0.75}{0.96} \times 1.35 = 1.05[\text{kW}]$$

Choose type:

SRC02 - P90B5 - 23.85 - 1.1kW-4 - M2

6. 速比与IEC接口 / RATIO AND IEC MOTOR ADAPTERS

SRC..01..P(IEC)				
i	63B5	71B5 71B14	80B5 80B14	90B5 90B14
53.33				
45.89				
40.10				
35.47				
28.50				
23.56				
(20.75)				
19.83				
17.86				
(15.6)				
14.62				
13.80*				
11.90				
(11.1)				
9.81				
9.17				
7.72				
5.69				
4.63				
3.82				

SRC..02..P(IEC)				
i	63B5	71B5 71B14	80B5 80B14	90B5 90B14
54.00*				
46.46*				
40.60*				
35.91*				
28.88*				
23.85*				
20.08*				
(19.87)				
17.10				
(14.94)				
14.81*				
13.21				
12.05				
(10.63)*				
9.93				
8.78				
7.39				
5.45				
4.43				
3.66				

SRC..03..P(IEC)					
i	71B5	80B5 80B14	90B5 90B14	100B5 100B14	112B5 112B14
51.30*					
44.18*					
38.63					
34.20*					
30.57					
24.99					
21.15*					
19.24*					
18.21*					
(15.93)					
15.30*					
(14.10)*					
13.30*					
12.60					
10.93*					
(10.3)					
9.08					
7.93*					
6.31					
5.48					
4.50					
3.74					

SRC..04..P(IEC)				
i	80B5 80B14	90B5 90B14	100B5 100B14	112B5 112B14
51.30*				
44.18*				
38.63				
34.20*				
30.57				
24.99				
21.15*				
19.24*				
(18.21)*				
(15.93)				
15.30*				
(14.10)*				
13.30*				
12.60				
10.93*				
(10.30)				
9.08				
7.93*				
6.31				
5.48				
4.50				
3.74				

“*” 表示速比可除尽 / Finite gear unit reduction ratio



() 表示尽量不用 / Barely suitable speed ratio

7. 减速器选型表 / GEAR UNIT SELECTION TABLES

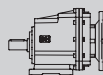
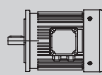

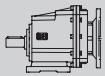
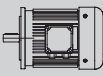
7.1 SRC..P(IEC).. 性能参数 / Performance parameter

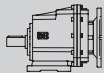
P _{1n} [KW]	n ₂ [r/min]	M _{2n} [Nm]	i	fs			Page	
0.12	26.3	42	53.33	2.9	SRC01	63B5	6314	21
	30.5	36	45.89	3.3	SRCF01	63B5	6314	21
	34.9	32	40.10	3.8	SRCZ01	63B5	6314	21
	39.5	28	35.47	4.3				
	49.1	22	28.50	5.4				
	59.4	18.5	23.56	6.5				
	70.6	15.6	19.83	7.7				
	78.4	14.0	17.86	7.1				
	95.8	11.5	14.62	10.4				
	101	10.8	13.80*	9.2				
	118	9.4	11.90	12.8				
	143	7.7	9.81	13.0				
	153	7.2	9.17	11.1				
	181	6.1	7.72	13.2				
	246	4.5	5.69	13.4				
302	3.6	4.63	16.5					
366	3.0	3.82	20.0					
0.18	16.9	98	53.33	1.2	SRC01	71B5	7116	21
	19.6	84	45.89	1.4	SRCF01	71B5	7116	21
	22.4	74	40.10	1.6	SRCZ01	71B5	7116	21
	25.4	65	35.47	1.8				
	31.6	52	28.50	2.3				
	26.3	63	53.33	1.9	SRC01	63B5	6324	21
	30.5	54	45.89	2.2	SRCF01	63B5	6324	21
	34.9	47	40.10	2.5	SRCZ01	63B5	6324	21
	39.5	42	35.47	2.9				
	49.1	34	28.50	3.6				
	59.4	28	23.56	4.3				
	70.6	23	19.83	5.1				
	78.4	21	17.86	4.8				
	95.8	17.2	14.62	7.0				
	101	16.3	13.80*	6.1				
118	14.0	11.90	8.6					
143	11.6	9.81	8.6					
153	10.8	9.17	7.4					
181	9.1	7.72	8.8					
246	6.7	5.69	8.9					
302	5.5	4.63	11.0					
366	4.5	3.82	13.3					
16.7	99	54.00*	2.0	SRC02	71B5	7116	23	
19.4	85	46.46*	2.3	SRCF02	71B5	7116	23	
22.2	74	40.60*	2.7	SRCZ02	71B5	7116	23	
25.1	66	35.91*	3.0					
31.2	53	28.88*	3.8					
25.9	64	54.00*	3.1	SRC02	63B5	6324	23	
30.1	55	46.46*	3.7	SRCF02	63B5	6324	23	
34.5	48	40.60*	4.2	SRCZ02	63B5	6324	23	

P_{1n} [KW]	n_2 [r/min]	M_{2n} [Nm]	i	f_s			Page	
0.25	16.9	136	53.33	0.88	SRC01	71B5/B14	7126	21
	19.6	117	45.89	1.0	SRCF01	71B5/B14	7126	21
	22.4	102	40.10	1.2	SRCZ01	71B5/B14	7126	21
	25.4	90	35.47	1.3				
	31.6	73	28.50	1.7				
	26.3	87	53.33	1.4	SRC01	71B5/B14	7114	21
	30.5	75	45.89	1.6	SRCF01	71B5/B14	7114	21
	34.9	66	40.10	1.8	SRCZ01	71B5/B14	7114	21
	39.5	58	35.47	2.1				
	49.1	47	28.50	2.6				
	59.4	39	23.56	3.1				
	70.6	32	19.83	3.7				
	78.4	29	17.86	3.4				
	95.8	24	14.62	5.0				
	101	23	13.80*	4.4				
	118	19.5	11.90	6.2				
	143	16.1	9.81	6.2				
	153	15.0	9.17	5.3				
	181	12.6	7.72	6.3				
	246	9.3	5.69	6.4				
	302	7.6	4.63	7.9				
	366	6.3	3.82	9.6				
	16.7	138	54.00*	1.5	SRC02	71B5/B14	7126	23
	19.4	118	46.46*	1.7	SRCF02	71B5/B14	7126	23
	22.2	103	40.60*	1.9	SRCZ02	71B5/B14	7126	23
	25.1	91	35.91*	2.2				
	31.2	74	28.88*	2.7				
	25.9	88	54.00*	2.3	SRC02	71B5/B14	7114	23
	30.1	76	46.46*	2.6	SRCF02	71B5/B14	7114	23
	34.5	66	40.60*	3.0	SRCZ02	71B5/B14	7114	23
	39.0	59	35.91*	3.4				
	48.5	47	28.88*	4.2				
	0.37	22.4	151	40.10*	0.79	SRC01	80B5/B14	8016
25.4		134	35.47*	0.90	SRCF01	80B5/B14	8016	21
31.6		107	28.50*	1.1	SRCZ01	80B5/B14	8016	21
38.2		89	23.56*	1.4				
26.3		129	53.33	0.93	SRC01	71B5/B14	7124	21
30.5		111	45.89	1.1	SRCF01	71B5/B14	7124	21
34.9		97	40.10	1.2	SRCZ01	71B5/B14	7124	21
39.5		86	35.47	1.4				
49.1		69	28.50	1.7				
59.4		57	23.56	2.1				
70.6		48	19.83	2.5				
78.4		43	17.86	2.3				
95.8		35	14.62	3.4				
101		33	13.80*	3.0				
118		29	11.90	4.2				
143		24	9.81	4.2				
153		22	9.17	3.6				
181		19	7.72	4.3				
246	14	5.69	4.4					
302	11	4.63	5.3					
366	9	3.82	6.5					

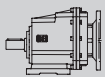
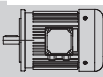
P_{1n} [KW]	n_2 [r/min]	M_{2n} [Nm]	i	f_s			Page	
0.37	16.7	204	54.00*	1.0	SRC02	80B5/B14	8016	23
	19.4	175	46.46*	1.1	SRCF02	80B5/B14	8016	23
	22.2	153	40.60*	1.3	SRCZ02	80B5/B14	8016	23
	25.1	135	35.91*	1.5				
	31.2	109	28.88*	1.8				
	25.9	131	54.00*	1.5	SRC02	71B5/B14	7124	23
	30.1	113	46.46*	1.8	SRCF02	71B5/B14	7124	23
	34.5	98	40.60*	2.0	SRCZ02	71B5/B14	7124	23
	39.0	87	35.91*	2.3				
	48.5	70	28.88*	2.9				
	58.7	58	23.85*	3.5				
	81.9	41	17.10	3.9				
	17.5	193	51.30*	1.6	SRC03	80B5/B14	8016	25
	20.4	167	44.18*	1.8	SRCF03	80B5/B14	8016	25
	23.3	146	38.63	2.1	SRCZ03	80B5/B14	8016	25
	26.3	129	34.20*	2.3				
	29.4	115	30.57	2.6				
	27.3	124	51.30*	2.4	SRC03	71B5	7124	25
	31.7	107	44.18*	2.8	SRCF03	71B5	7124	25
	36.2	94	38.63	3.2	SRCZ03	71B5	7124	25
40.9	83	34.20*	3.6					
0.55	31.6	160	28.50	0.75	SRC01	80B5/B14	8026	21
	38.2	132	23.56	0.91	SRCF01	80B5/B14	8026	21
	45.4	111	19.83	1.1	SRCZ01	80B5/B14	8026	21
	34.9	144	40.10	0.8	SRC01	80B5/B14	8014	21
	39.5	128	35.47	0.9	SRCF01	80B5/B14	8014	21
	49.1	103	28.50	1.2	SRCZ01	80B5/B14	8014	21
	59.4	85	23.56	1.4				
	70.6	71	19.83	1.7				
	78.4	64	17.86	1.6				
	95.8	53	14.62	2.3				
	101	50	13.80*	2.0				
	118	43	11.90	2.8				
	143	35	9.81	2.8				
	153	33	9.17	2.4				
	181	28	7.72	2.9				
	246	20	5.69	2.9				
	302	17	4.63	3.6				
	366	14	3.82	4.4				
	19.4	260	46.46*	0.77	SRC02	80B5/B14	8026	23
	22.2	227	40.60*	0.88	SRCF02	80B5/B14	8026	23
25.1	201	35.91*	1.0	SRCZ02	80B5/B14	8026	23	
31.2	162	28.88*	1.2					
37.7	134	23.85*	1.5					
25.9	194	54.00*	1.0	SRC02	80B5/B14	8014	23	
30.1	167	46.46*	1.2	SRCF02	80B5/B14	8014	23	
34.5	146	40.60*	1.4	SRCZ02	80B5/B14	8014	23	
39.0	129	35.91*	1.5					
48.5	104	28.88*	1.9					
58.7	86	23.85*	2.3					

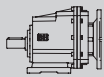
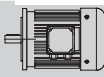
P_{1n} [KW]	n_2 [r/min]	M_{2n} [Nm]	i	f_s			Page	
0.55	69.7	72	20.08*	2.8	SRC02	80B5/B14	8014	23
	81.9	62	17.10	2.6	SRCF02	80B5/B14	8014	23
	94.5	53	14.81*	3.7	SRCZ02	80B5/B14	8014	23
	17.5	287	51.30*	1.0	SRC03	80B5/B14	8026	25
	20.4	248	44.18*	1.2	SRCF03	80B5/B14	8026	25
	23.3	216	38.63	1.4	SRCZ03	80B5/B14	8026	25
	26.3	192	34.20*	1.6				
	29.4	171	30.57	1.8				
	27.3	185	51.30*	1.6	SRC03	80B5/B14	8014	25
	21.7	159	44.18*	1.9	SRCF03	80B5/B14	8014	25
	36.2	139	38.63	2.2	SRCZ03	80B5/B14	8014	25
	40.9	123	34.20*	2.4				
	45.8	110	30.57	2.7				
	56.0	90	24.99	3.3				
	0.75	49.1	140	28.50	0.86	SRC01	80B5/B14	8024
59.4		116	23.56	1.0	SRCF01	80B5/B14	8024	21
70.6		97	19.83	1.2	SRCZ01	80B5/B14	8024	21
78.4		88	17.86	1.1				
95.8		72	14.62	1.7				
101		68	13.80*	1.5				
118		58	11.90	2.1				
143		48	9.81	2.1				
153		45	9.17	1.8				
181		38	7.72	2.1				
246		28	5.69	2.1				
302		23	4.63	2.6				
366		19	3.82	3.2				
31.2		221	28.88*	0.91	SRC02	90B5/B14	90S6	23
37.7		182	23.85*	1.1	SRCF02	90B5/B14	90S6	23
44.8		153	20.08*	1.3	SRCZ02	90B5/B14	90S6	23
30.1		228	48.46*	0.88	SRC02	80B5/B14	8024	23
34.5		199	40.60*	1.0	SRCF02	80B5/B14	8024	23
39.0		176	35.91*	1.1	SRCZ02	80B5/B14	8024	23
48.5		142	28.88*	1.4				
58.7		117	23.85*	1.7				
69.7		99	20.08*	2.0				
81.9		84	17.10	1.9				
94.5		73	14.81*	2.7				
106		65	13.21	2.5				
116.2		59	12.05	3.4				
141		49	9.93	3.3				
159		43	8.78	2.8				
189		36	7.39	3.3				
257		27	5.45	3.7				
97.0		71	28.88*	2.8	SRC02	80B5/B14	8012	23
117.4		59	23.85*	3.4	SRCF02	80B5/B14	8012	23
139.4		49	20.08*	4.1	SRCZ02	80B5/B14	8012	23
163.7	42	17.10	3.8					

P_{1n} [KW]	n_2 [r/min]	M_{2n} [Nm]	i	f_s				Page
0.75	17.5	392	51.30*	0.77	SRC03	90B5/B14	90S6	25
	20.4	338	44.18*	0.89	SRCF03	90B5/B14	90S6	25
	23.3	295	38.63	1.0	SRCZ03	90B5/B14	90S6	25
	26.3	261	34.20*	1.1				
	29.4	234	30.57	1.3				
	36.0	191	24.99	1.6				
	27.3	252	51.30*	1.2	SRC03	80B5/B14	8024	25
	31.7	217	44.18*	1.4	SRCF03	80B5/B14	8024	25
	36.2	190	38.63	1.6	SRCZ03	80B5/B14	8024	25
	40.9	168	34.20*	1.8				
	45.8	150	30.57	2.0				
	56.0	123	24.99	2.4				
	66.2	104	21.15*	2.7				
	72.8	94	19.24*	3.0				
	76.9	89	18.21*	3.1				
	91.5	75	15.30*	3.7				
	105	65	13.30*	3.8				
	111	62	12.60	4.0				
	17.5	392	51.30*	1.3	SRC04	90B5/B14	90S6	27
	20.4	338	44.18*	1.5	SRCF04	90B5/B14	90S6	27
	23.3	295	38.63	1.7	SRCZ04	90B5/B14	90S6	27
	26.3	261	34.20*	1.8				
	29.4	234	30.57	2.1				
	27.3	252	51.30*	2.0	SRC04	80B5/B14	8024	27
	31.7	217	44.18*	2.3	SRCF04	80B5/B14	8024	27
	36.2	190	38.63	2.6	SRCZ04	80B5/B14	8024	27
	40.9	168	34.20*	2.9				
45.8	150	30.57	3.2					
56.0	123	24.99	3.9					
66.2	104	21.15*	4.0					
1.1	70.6	143	19.83	0.84	SRC01	90B5/B14	90S4	21
	78.4	129	17.86	0.78	SRCF01	90B5/B14	90S4	21
	95.8	105	14.62	1.1	SRCZ01	90B5/B14	90S4	21
	101	99	13.80*	1.0				
	118	86	11.90	1.4				
	143	71	9.81	1.4				
	153	66	9.17	1.2				
	181	56	7.72	1.4				
	246	41	5.69	1.5				
	302	33	4.63	1.8				
	366	28	3.82	2.2				
	285	35	9.81	2.8	SRC01	80B5/B14	8022	21
	305	33	9.17	2.4	SRCF01	80B5/B14	8022	21
	363	28	7.72	2.9	SRCZ01	80B5/B14	8022	21
	492	20	5.69	2.9				
	605	17	4.63	3.6				
	733	14	3.82	4.4				
	39.0	259	35.91*	0.77	SRC02	90B5/B14	90S4	23
	48.5	208	28.88*	1.0	SRCF02	90B5/B14	90S4	23
	58.7	172	23.85*	1.2	SRCZ02	90B5/B14	90S4	23
	69.7	145	20.08*	1.4				
81.9	123	17.10	1.3					

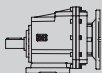
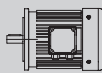
P_{1n} [KW]	n_2 [r/min]	M_{2n} [Nm]	i	f_s			Page	
1.1	94.5	107	14.81*	1.9	SRC02	90B5/B14	90S4	23
	106	95	13.21	1.7	SRCF02	90B5/B14	90S4	23
	116	87	12.05	2.3	SRCZ02	90B5/B14	90S4	23
	141	72	9.93	2.2				
	159	63	8.78	1.9				
	189	53	7.39	2.3				
	257	39	5.45	2.5				
	316	32	4.43	3.1				
	383	26	3.66	3.8				
	27.3	370	51.30*	0.81	SRC03	90B5/B14	90S4	25
	31.7	318	44.18*	0.94	SRCF03	90B5/B14	90S4	25
	36.2	278	38.63	1.1	SRCZ03	90B5/B14	90S4	25
	40.9	246	34.20*	1.2				
	45.8	220	30.57	1.4				
	56.0	180	24.99	1.7				
	66.2	152	21.15*	1.8				
	72.8	139	19.24*	2.0				
	76.9	131	18.21*	2.1				
	91.5	110	15.30*	2.5				
	72.5	139	38.63	2.2	SRC03	80B5/B14	8022	25
	81.9	123	34.20*	2.4	SRCF03	80B5/B14	8022	25
	91.6	110	30.57	2.7	SRCZ03	80B5/B14	8022	25
	112.0	90	24.99	3.3				
	132.4	76	21.15*	3.7				
	145.5	69	19.24*	4.0				
	153.8	66	18.21*	4.3				
	27.3	370	51.30*	1.4	SRC04	90B5/B14	90S4	27
	31.7	318	44.18*	1.6	SRCF04	90B5/B14	90S4	27
	36.2	278	38.63	1.8	SRCZ04	90B5/B14	90S4	27
	40.9	246	34.20*	1.9				
45.8	220	30.57	2.2					
56.0	180	24.99	2.7					
66.2	152	21.15*	2.8					
72.8	139	19.24*	3.0					
76.9	131	18.21*	3.2					
91.5	110	15.30*	3.8					
105	96	13.30	3.7					
1.5	118	117	11.90	1.0	SRC01	90B5/B14	90L4	21
	143	96	9.81	1.0	SRCF01	90B5/B14	90L4	21
	153	90	9.17	0.9	SRCZ01	90B5/B14	90L4	21
	181	76	7.72	1.1				
	246	56	5.69	1.1				
	302	45	4.63	1.3				
	366	38	3.82	1.6				
	305	45	9.17	1.8	SRC01	90B5/B14	90S2	21
	363	38	7.72	2.1	SRCF01	90B5/B14	90S2	21
	492	28	5.69	2.1	SRCZ01	90B5/B14	90S2	21
	605	23	4.63	2.6				
	733	19	3.82	3.2				

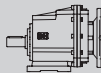
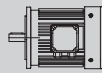
P_{1n} [KW]	n_2 [r/min]	M_{2n} [Nm]	i	f_s			Page	
1.5	58.7	234	23.85*	0.85	SRC02	90B5/B14	90L4	23
	69.7	197	20.08*	1.0	SRCF02	90B5/B14	90L4	23
	81.9	168	17.10	1.0	SRCZ02	90B5/B14	90L4	23
	94.5	145	14.81*	1.4				
	106	130	13.21	1.2				
	116	118	12.05	1.7				
	141	98	9.93	1.6				
	159	86	8.78	1.4				
	189	73	7.39	1.7				
	257	54	5.45	1.9				
	316	44	4.43	2.3				
	383	36	3.66	2.8				
	212	65	13.21	2.5	SRC02	90B5/B14	90S2	23
	232	59	12.05	3.4	SRCF02	90B5/B14	90S2	23
	282	49	9.93	3.3	SRCZ02	90B5/B14	90S2	23
	319	43	8.78	2.8				
	379	36	7.39	3.3				
	514	27	5.45	3.7				
	40.9	336	34.20*	0.89	SRC03	90B5/B14	90L4	25
	45.8	300	30.57	1.0	SRCF03	90B5/B14	90L4	25
	56.0	245	24.99	1.2	SRCZ03	90B5/B14	90L4	25
	66.2	208	21.15*	1.3				
	72.8	189	19.24*	1.5				
	76.9	179	18.21*	1.6				
	91.5	150	15.30*	1.9				
	105	131	13.30*	1.9				
	111	124	12.60	2.0				
	128	107	10.93*	1.7				
	154	89	9.08	2.0				
	177	78	7.93*	2.3				
	222	62	6.31	2.9				
	255	54	5.48	2.8				
	311	44	4.50	3.4				
	374	37	3.74	4.1				
	256	54	10.93*	3.4	SRC03	90B5/B14	90S2	25
	308	45	9.08	4.0	SRCF03	90B5/B14	90S2	25
	353	39	7.93*	4.6	SRCZ03	90B5/B14	90S2	25
	26.3	523	34.20*	0.92	SRC04	100B5/B14	100L6	27
	29.4	467	30.57	1.0	SRCF04	100B5/B14	100L6	27
	36.0	382	24.99	1.3	SRCZ04	100B5/B14	100L6	27
	27.3	504	51.30*	1.0	SRC04	90B5/B14	90L4	27
	31.7	434	44.18*	1.2	SRCF04	90B5/B14	90L4	27
	36.2	379	38.63	1.3	SRCZ04	90B5/B14	90L4	27
	40.9	336	34.20*	1.4				
	45.8	300	30.57	1.6				
56.0	245	24.99	2.0					
66.2	208	21.15*	2.0					
72.8	189	19.24*	2.2					
76.9	179	18.21*	2.3					
91.5	150	15.30*	2.8					
105	131	13.30*	2.7					
111	124	12.60	2.8					
128	107	10.93*	2.6					
154	89	9.08	3.1					
177	78	7.93	3.3					

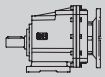
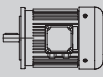
P_{1n} [KW]	n_2 [r/min]	M_{2n} [Nm]	i	f_s			Page	
2.2	72.8	277	19.24*	1.0	SRC03	100B5/B14	100L14	25
	91.5	220	15.30*	1.1	SRCF03	100B5/B14	100L14	25
	105	192	13.30*	1.3	SRCZ03	100B5/B14	100L14	25
	111	182	12.60*	1.4				
	128	157	10.93*	1.1				
	154	131	9.08	1.4				
	177	114	7.93*	1.6				
	222	91	6.31	2.0				
	255	79	5.48	1.9				
	311	65	4.50	2.3				
	374	54	3.74	2.8				
	308	65	9.08	2.8	SRC03	90B5/B14	90L2	25
	353	57	7.93*	3.2	SRCF03	90B5/B14	90L2	25
	444	45	6.31	4.0	SRCZ03	90B5/B14	90L2	25
	511	39	5.48	3.8				
	36.0	560	24.99	0.86	SRC04	112B5/B14	112M6	27
	46.8	431	19.24*	1.0	SRCF04	112B5/B14	112M6	27
					SRCZ04	112B5/B14	112M6	27
	40.9	493	34.20*	1.0	SRC04	100B5/B14	100L14	27
	45.8	440	30.57	1.1	SRCF04	100B5/B14	100L14	27
	56.0	360	24.99	1.3	SRCZ04	100B5/B14	100L14	27
	72.8	277	19.24*	1.5				
	91.5	220	15.30*	1.9				
	105	192	13.30*	1.8				
	111	182	12.60	1.9				
	128	157	10.93*	1.8				
	154	131	9.08	2.1				
	177	114	7.93*	2.3				
	222	91	6.31	2.9				
	255	79	5.48	2.9				
	311	65	4.50	3.5				
	374	54	3.74	4.3				
3	91.5	301	15.30*	0.93	SRC03	100B5/B14	100L24	25
	105	261	13.30*	1.0	SRCF03	100B5/B14	100L24	25
	111	248	12.60	1.0	SRCZ03	100B5/B14	100L24	25
	128	215	10.93*	0.8				
	154	178	9.08	1.0				
	177	156	7.93*	1.2				
	222	124	6.31	1.5				
	255	108	5.48	1.4				
	311	88	4.50	1.7				
	374	73	3.74	2.0				
	45.8	601	30.57	0.80	SRC04	100B5/B14	100L24	27
	56.0	491	24.99	1.0	SRCF04	100B5/B14	100L24	27
	72.8	378	19.24*	1.1	SRCZ04	100B5/B14	100L24	27
	91.5	301	15.30*	1.4				
	105	261	13.30*	1.3				
	111	248	12.60	1.4				
	128	215	10.93*	1.3				
	154	178	9.08	1.6				

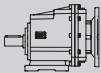
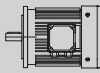
P_{1n} [KW]	n_2 [r/min]	M_{2n} [Nm]	i	f_s			Page	
3	177	156	7.93*	1.7	SRC04	100B5/B14	100L24	27
	222	124	6.31	2.1	SRCF04	100B5/B14	100L24	27
	255	108	5.48	2.1	SRCZ04	100B5/B14	100L24	27
	311	88	4.50	2.6				
	374	73	3.74	3.1				
	308	89	9.08	3.1	SRC04	100B5/B14	100L2	27
	353	78	7.93*	3.3	SRCF04	100B5/B14	100L2	27
	444	62	6.31	4.2	SRCZ04	100B5/B14	100L2	27
	511	54	5.48	4.3				
4	177	208	7.93*	0.87	SRC03	112B5/B14	112M4	25
	222	165	6.31	1.1	SRCF03	112B5/B14	112M4	25
	255	144	5.48	1.0	SRCZ03	112B5/B14	112M4	25
	311	118	4.50	1.3				
	374	98	3.74	1.5				
	105	348	13.30*	1.0	SRC04	112B5/B14	112M4	27
	111	330	12.60	1.1	SRCF04	112B5/B14	112M4	27
	128	286	10.93*	1.0	SRCZ04	112B5/B14	112M4	27
	154	238	9.08	1.2				
	177	208	7.93*	1.3				
	222	165	6.31	1.6				
	255	144	5.48	1.6				
	311	118	4.50	2.0				
	374	98	3.74	2.3				
	308	119	9.08	2.4	SRC04	112B5/B14	112M2	27
	353	104	7.93*	2.5	SRCF04	112B5/B14	112M2	27
	444	83	6.31	3.1	SRCZ04	112B5/B14	112M2	27
	511	72	5.48	3.2				
	622	59	4.50	3.9				

7.2 SRC..HS.. 性能参数 / Performance parameter

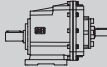
M _{2max} [Nm]	n ₁ [r/min]	i	P _{1n} [kW]	n ₂ [r/min]		Page ←→
120	1400	53.33	0.34	26.3	SRC01-HS	22
120	1400	45.89	0.40	30.5	SRCF01-HS	22
120	1400	40.10	0.46	34.9	SRCZ01-HS	22
120	1400	35.47	0.52	39.5		
120	1400	28.50	0.64	49.1		
120	1400	23.56	0.78	59.4		
120	1400	19.83	0.92	70.6		
100	1400	17.86	0.86	78.4		
120	1400	14.62	1.25	95.7		
100	1400	13.80*	1.10	101		
120	1400	11.90	1.54	118		
100	1400	9.81	1.56	143		
80	1400	9.17	1.34	153		
80	1400	7.72	1.58	181		
60	1400	5.69	1.61	246		
60	1400	4.63	1.98	302		
60	1400	3.82	2.40	367		
200	1400	54.00*	0.57	25.9	SRC02-HS	24
200	1400	46.46*	0.66	30.1	SRCF02-HS	24
200	1400	40.60*	0.75	34.5	SRCZ02-HS	24
200	1400	35.91*	0.85	39.0		
200	1400	28.88*	1.06	48.5		
200	1400	23.85*	1.28	58.7		
200	1400	20.08	1.52	69.7		
160	1400	17.10	1.43	81.9		
200	1400	14.81*	2.06	94.6		
160	1400	13.21	1.85	106		
200	1400	12.05	2.53	116		
160	1400	9.93	2.46	141		
120	1400	8.78	2.08	159		
120	1400	7.39	2.49	190		
100	1400	5.45	2.80	257		
100	1400	4.43	3.45	316		
100	1400	3.66	4.18	383		

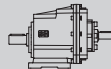
M_{2max} [Nm]	n_1 [r/min]	i	P_{1n} [kW]	n_2 [r/min]		Page ←→
300	1400	51.30 *	0.89	27.3	SRC03-HS	26
300	1400	44.18 *	1.04	31.7	SRCF03-HS	26
300	1400	38.63	1.19	36.2	SRCZ03-HS	26
300	1400	34.20 *	1.34	40.9		
300	1400	30.57	1.50	45.8		
300	1400	24.99	1.83	56.0		
280	1400	21.15 *	2.02	66.2		
280	1400	19.24*	2.22	72.8		
250	1400	18.21*	2.10	76.9		
280	1400	15.30*	2.79	91.5		
250	1400	13.30 *	2.86	105		
250	1400	12.60	3.03	111		
180	1400	10.93	2.51	128		
180	1400	9.08	3.02	154		
180	1400	7.93*	3.46	176		
180	1400	6.31	4.36	222		
150	1400	5.48	4.17	255		
150	1400	4.50	5.09	311		
150	1400	3.74	6.12	374		
500	1400	51.30*	1.49	27.3	SRC04-HS	28
500	1400	44.18*	1.73	31.7	SRCF04-HS	28
500	1400	38.63	1.98	36.2	SRCZ04-HS	28
480	1400	34.20*	2.14	40.9		
480	1400	30.57	2.40	45.8		
480	1400	24.99	2.93	56.0		
480	1400	21.15*	2.02	66.2		
420	1400	19.24*	3.34	72.8		
420	1400	15.30*	4.19	91.5		
350	1400	13.30*	4.01	105		
350	1400	12.60	4.24	111		
280	1400	10.93	3.91	128		
280	1400	9.08	4.70	154		
260	1400	7.93*	4.99	176		
260	1400	6.31	6.30	222		
230	1400	5.48	6.40	255		
230	1400	4.50	7.80	311		
230	1400	3.74	9.38	374		

8. 外形尺寸图表 / OUTLINE DIMENSION SHEET

SRC01..P(IEC)

输入 / INPUT

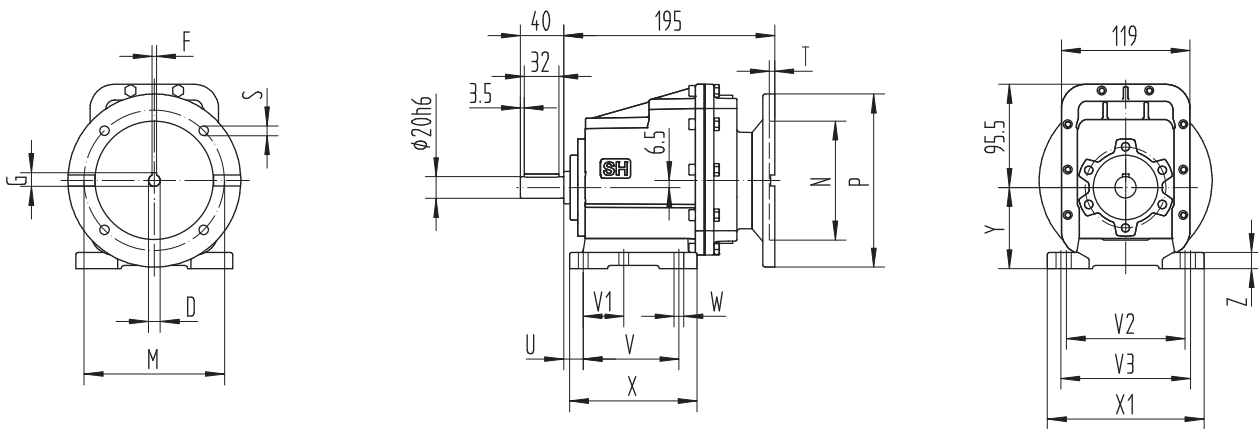

SRCF01..P(IEC)

输出 / OUTPUT

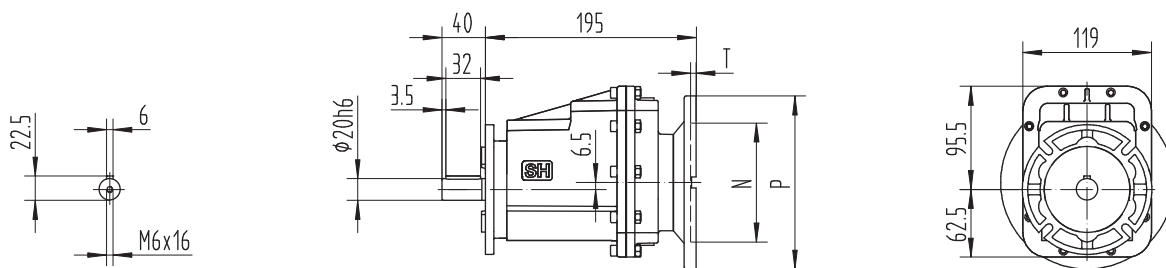

SRCZ01..P(IEC)

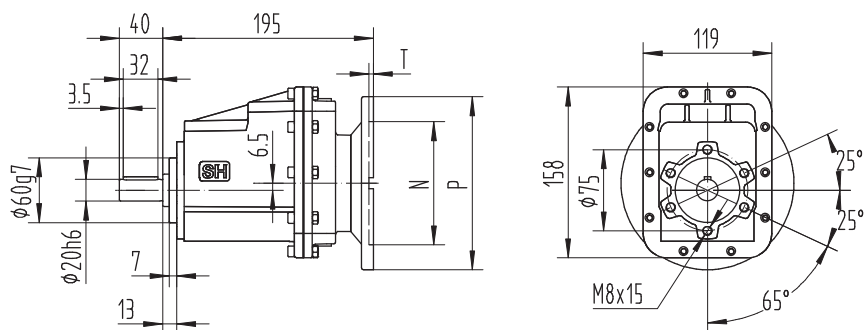

IEC	D	F	G	P	M	N	S	T
63B5	11	4	12.8	140	115	95	9	5
71B5	14	5	16.3	160	130	110	9	5
71B14	14	5	16.3	105	85	70	7	5
80B5	19	6	21.8	200	165	130	11	5
80B14	19	6	21.8	120	100	80	7	5
90B5	24	8	27.3	200	165	130	11	5
90B14	24	8	27.3	140	115	95	9	5

底脚代号 Foot Code	U	V	V1	V2	V3	W	X	X1	Y	Z
B01	18	87	50	110	—	9	118	130	85	15
M01	18	80	—	110	120	9	118	145	75	15
M02	25	85	—	110	120	9	112	145	75	15
B02	18	107.5	60	—	130	11	136	155	95	17

SRC01..HS

输入 / INPUT

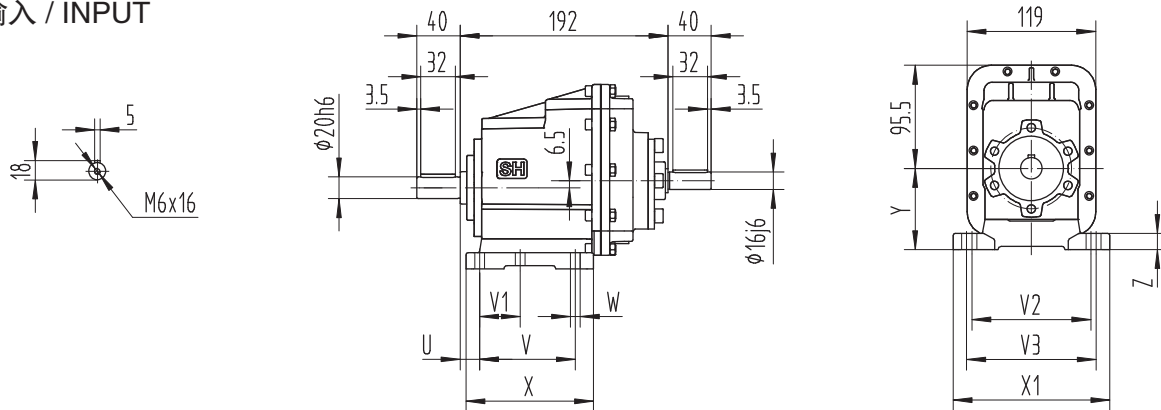

SRCF01..HS

输出 / OUTPUT

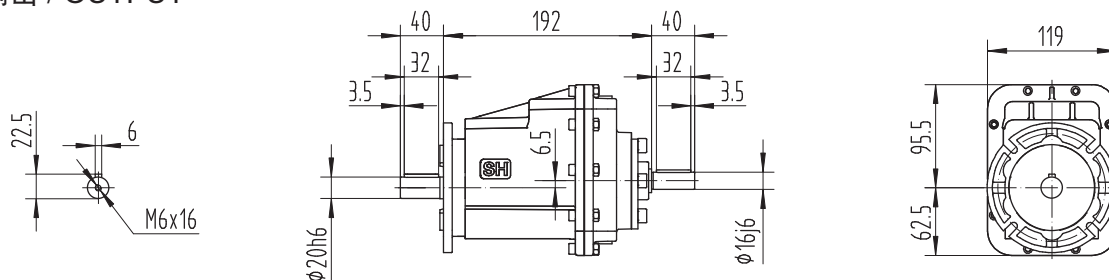

SRCZ01..HS

输出法兰 / OUTPUT FLANGE

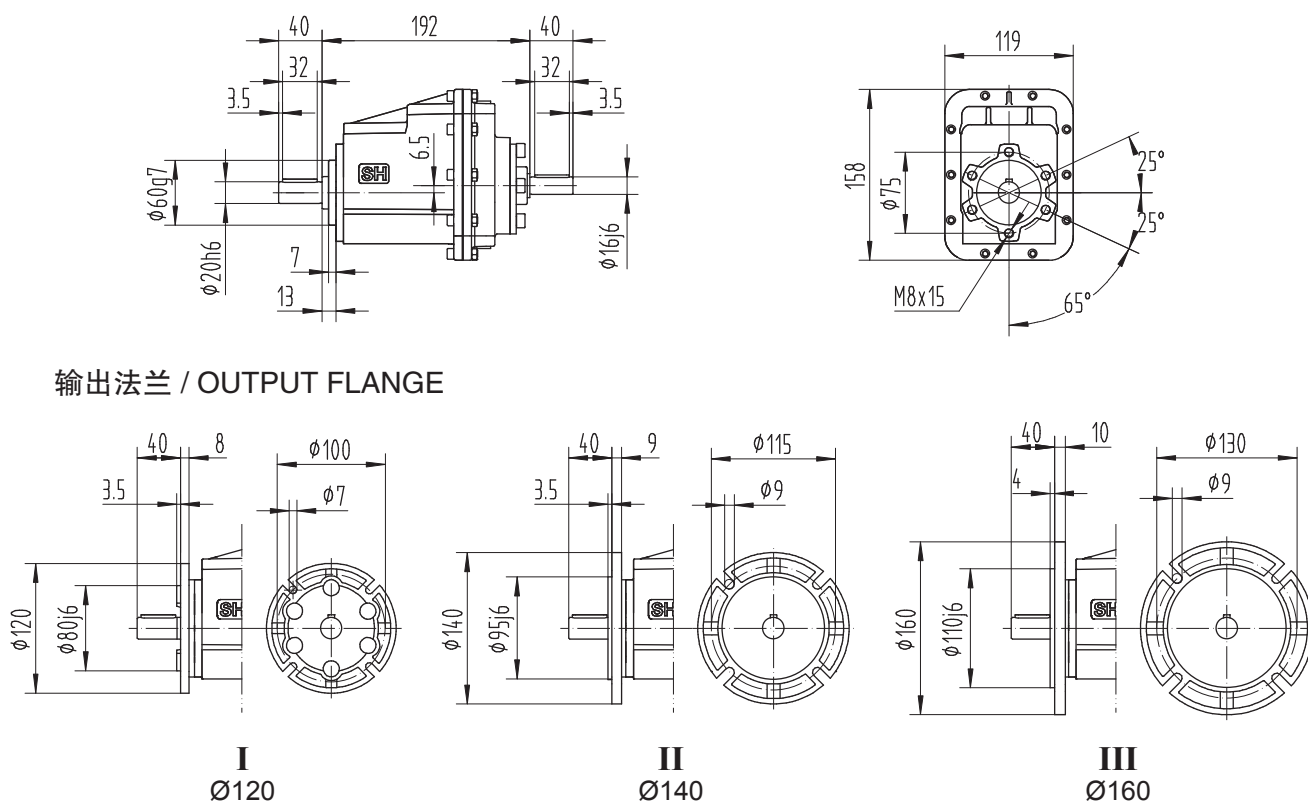

SRC02..P(IEC)

输入 / INPUT

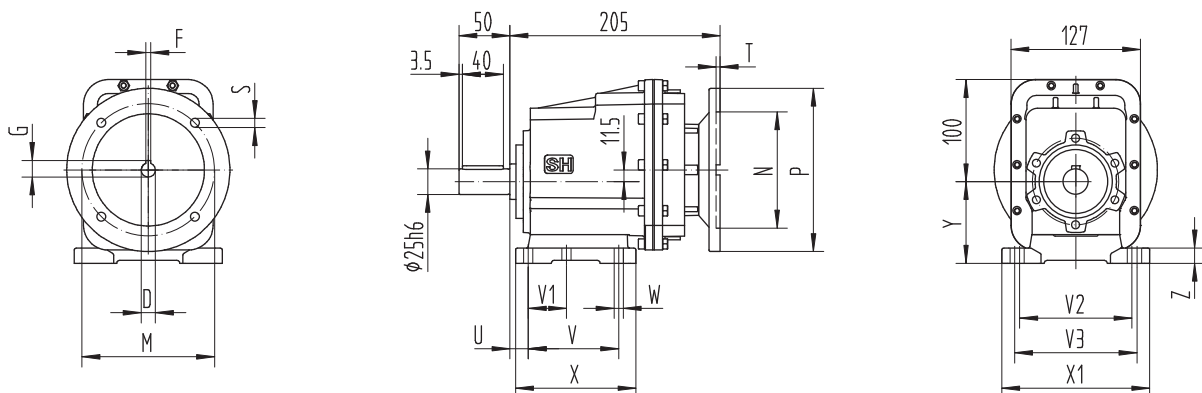

SRCF02..P(IEC)

输出 / OUTPUT

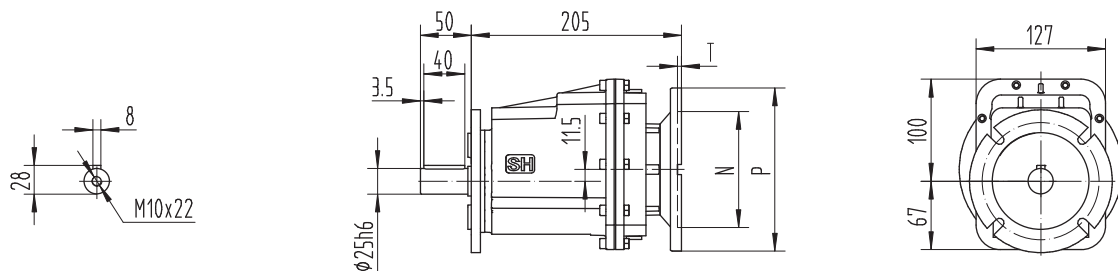

SRCZ02..P(IEC)

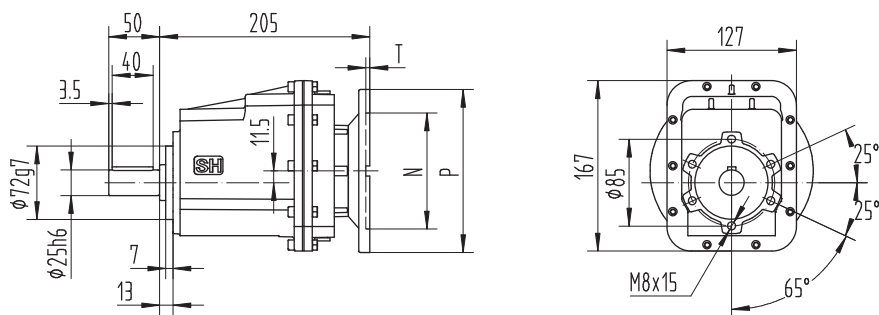

IEC	D	F	G	P	M	N	S	T
63B5	11	4	12.8	140	115	95	9	5
71B5	14	5	16.3	160	130	110	9	5
71B14	14	5	16.3	105	85	70	7	5
80B5	19	6	21.8	200	165	130	11	5
80B14	19	6	21.8	120	100	80	7	5
90B5	24	8	27.3	200	165	130	11	5
90B14	24	8	27.3	140	115	95	9	5

底脚代号 Foot Code	U	V	V1	V2	V3	W	X	X1	Y	Z
B02	18	107.5	60	—	130	11	136	155	100	17
M02	25	85	—	110	120	9	112	145	80	15
M01	18	80	—	110	120	9	118	145	80	15
B01	18	87	50	110	—	9	118	130	90	15

SRC02..HS

输入 / INPUT

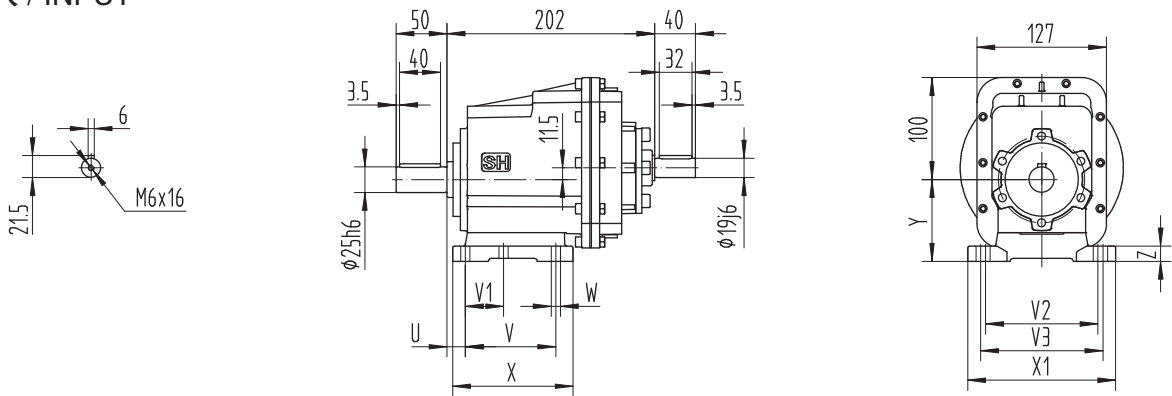

SRCF02..HS

输出 / OUTPUT

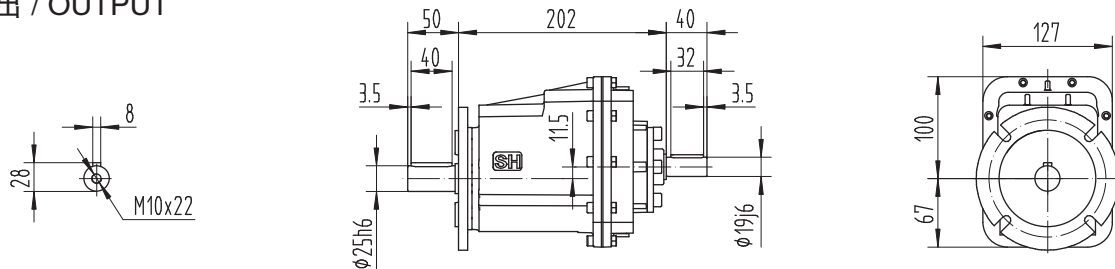

SRCZ02..HS

输出法兰 / OUTPUT FLANGE

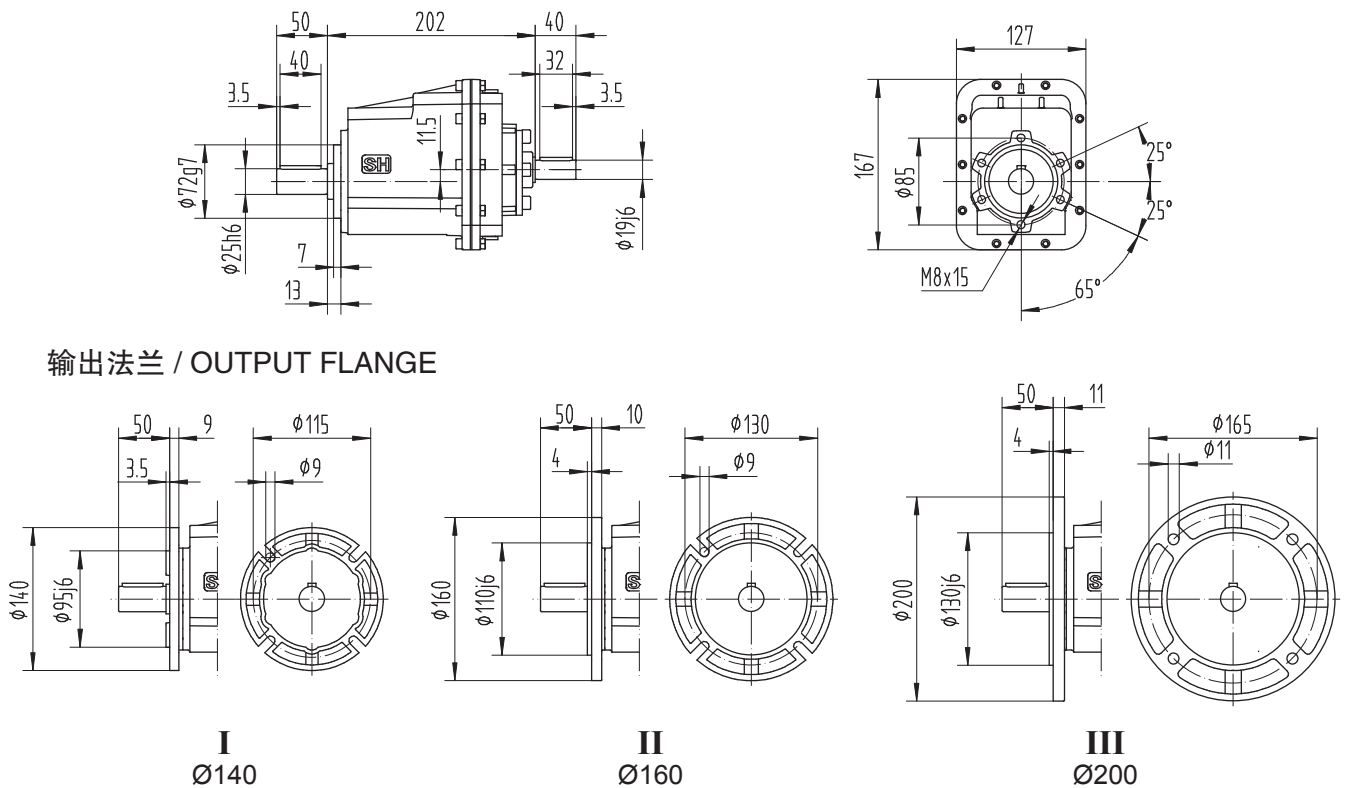

SRC03..P(IEC)

输入 / INPUT

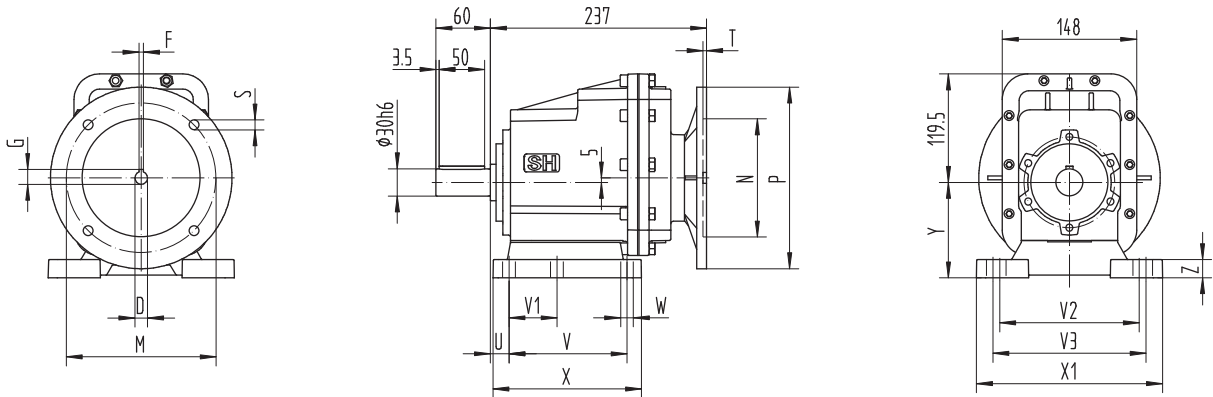

SRCF03..P(IEC)

输出 / OUTPUT

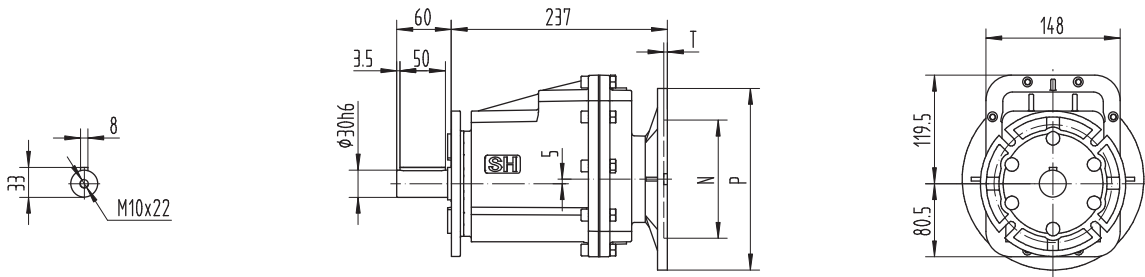

SRCZ03..P(IEC)

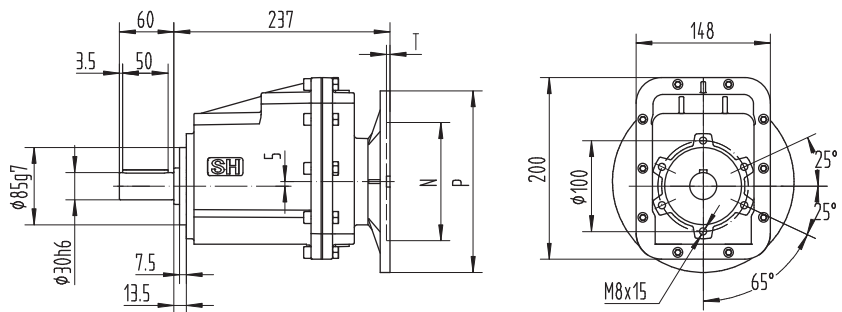

IEC	D	F	G	P	M	N	S	T
71B5	14	5	16.3	160	130	110	9	5
80B5	19	6	21.8	200	165	130	11	5
80B14	19	6	21.8	120	100	80	7	5
90B5	24	8	27.3	200	165	130	11	5
90B14	24	8	27.3	140	115	95	9	5
100/112B5	28	8	31.3	250	215	180	13.5	5
100/112B14	28	8	31.3	160	130	110	9	5

底脚代号 Foot Code	U	V	V1	V2	V3	W	X	X1	Y	Z
B03	18	130	70	—	160	11	156	190	110	20
M03	30	100	—	135	150	11	150	190	110	18
M04	32	110	—	170	185	14	150	230	110	20
B04	20.5	130	—	170	—	14	168	205	105	20

SRC03..HS

输入 / INPUT

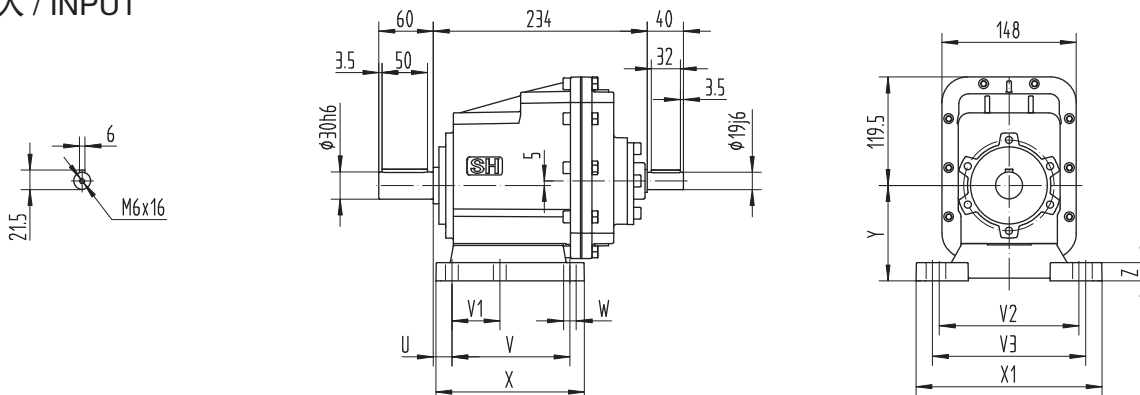

SRCF03..HS

输出 / OUTPUT

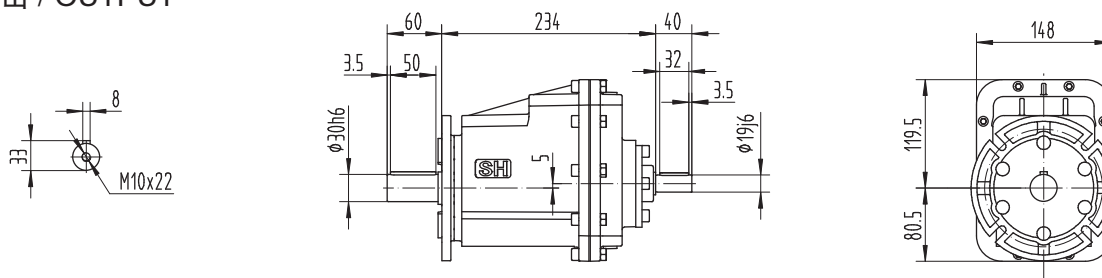

SRCZ03..HS

输出法兰 / OUTPUT FLANGE

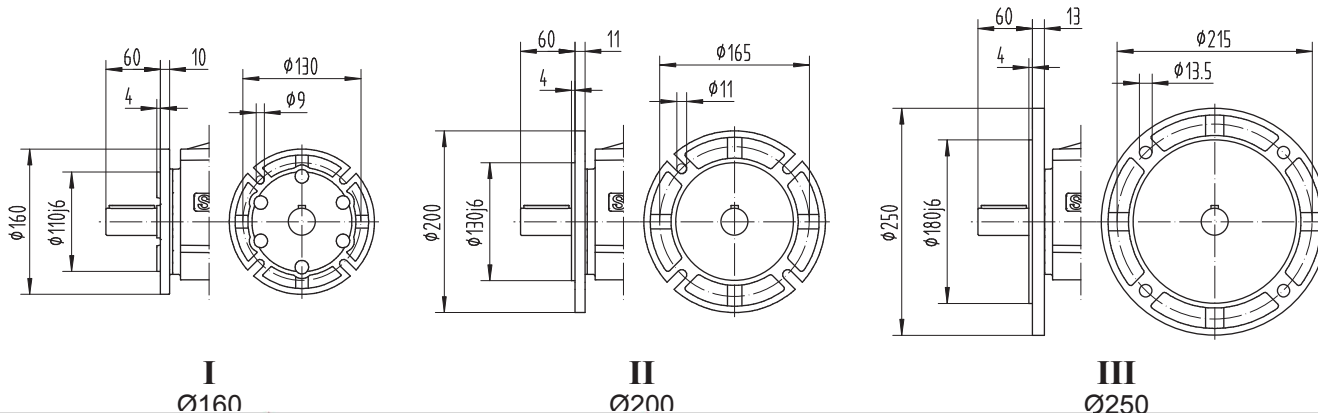
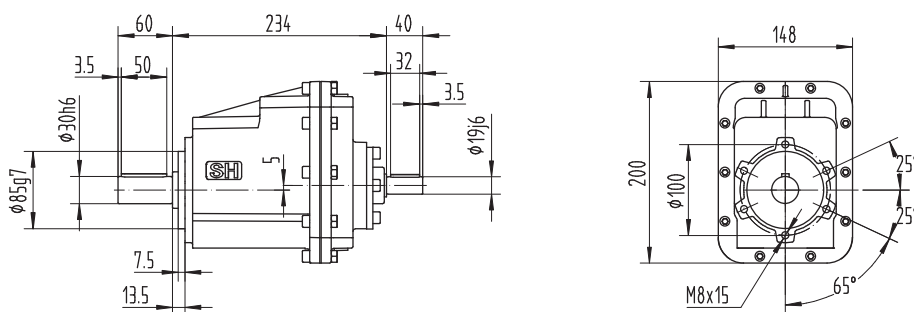

SRC04..P(IEC)

输入 / INPUT

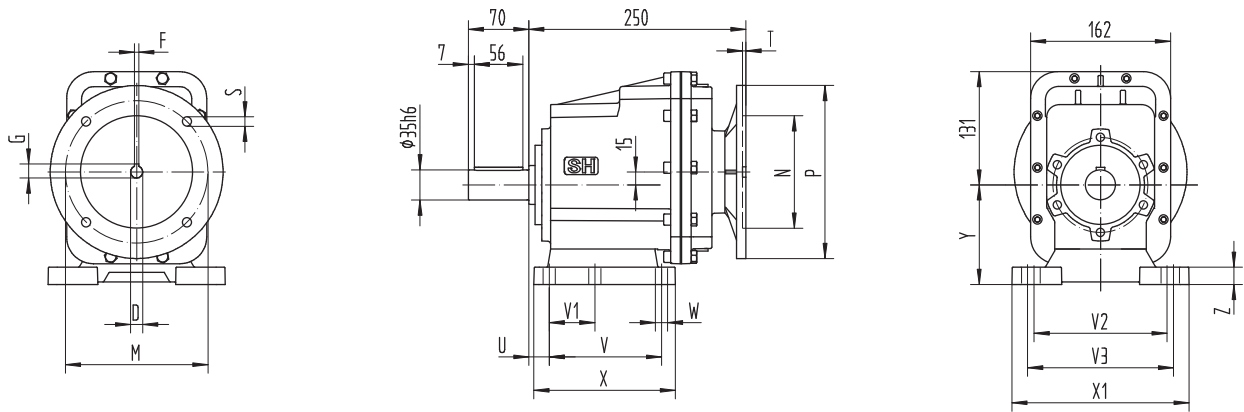

SRCF04..P(IEC)

输出 / OUTPUT

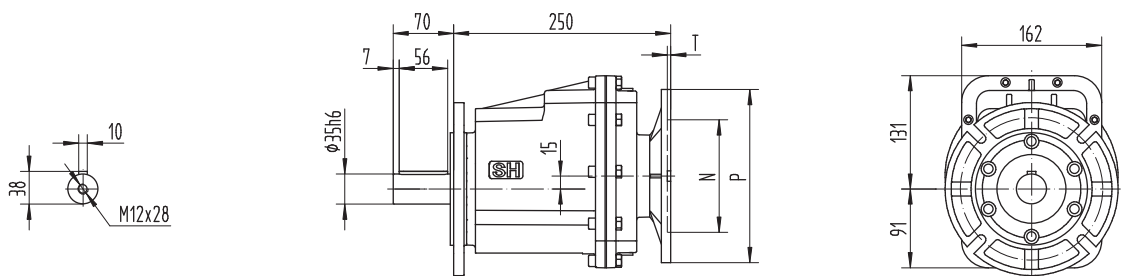

SRCZ04..P(IEC)

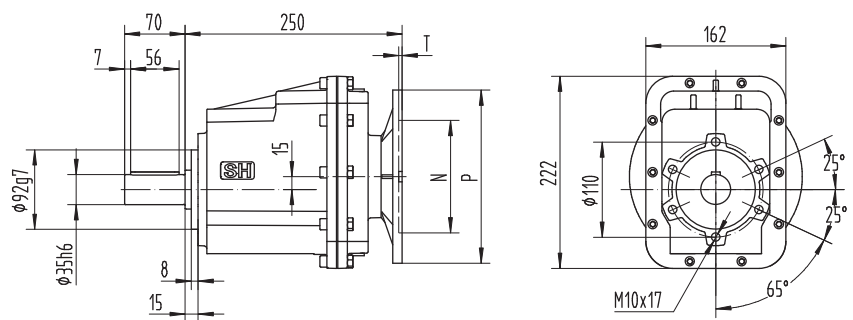

IEC	D	F	G	P	M	N	S	T
80B5	19	6	21.8	200	165	130	11	5
80B14	19	6	21.8	120	100	80	7	5
90B5	24	8	27.3	200	165	130	11	5
90B14	24	8	27.3	140	115	95	9	5
100/112B5	28	8	31.3	250	215	180	13.5	5
100/112B14	28	8	31.3	160	130	110	9	5

底脚代号 Foot Code	U	V	V1	V2	V3	W	X	X1	Y	Z
B04	23.5	130	—	170	—	14	168	205	115	20
B05	19.5	149.5	—	180	—	14	185	215	130	20
M04	35	110	—	170	185	14	150	230	120	20
M03	33	100	—	135	150	11	150	190	120	18
B03	21	130	70	—	160	11	156	190	120	20

SRC04..HS

输入 / INPUT

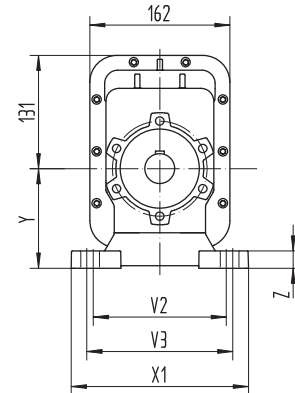
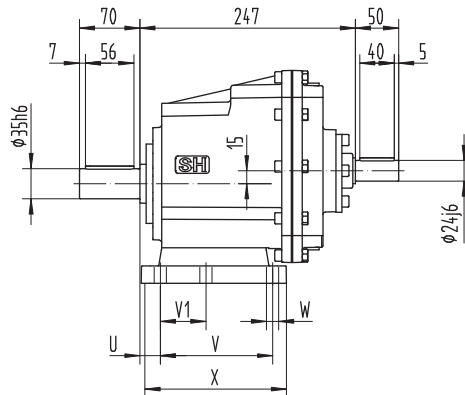
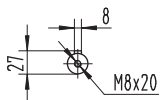

SRCF04..HS

输出 / OUTPUT

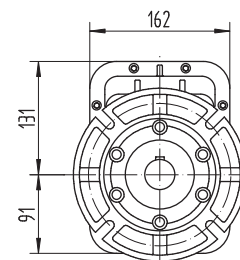
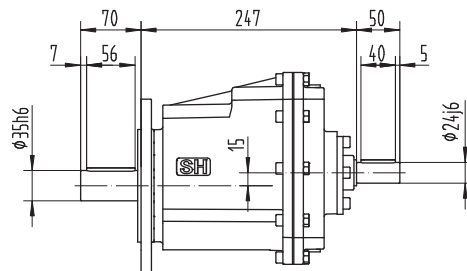
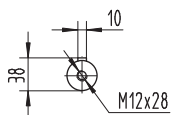

SRCZ04..HS

输出法兰 / OUTPUT FLANGE

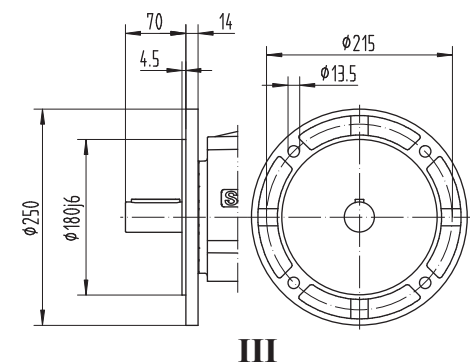
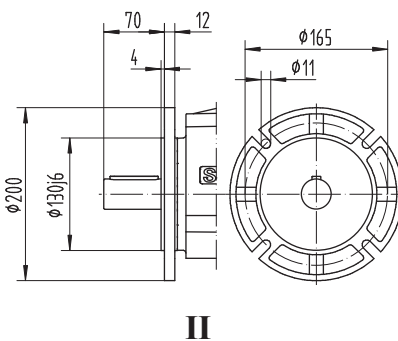
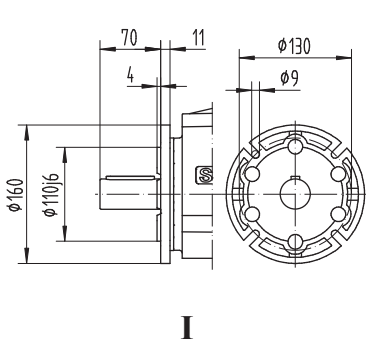
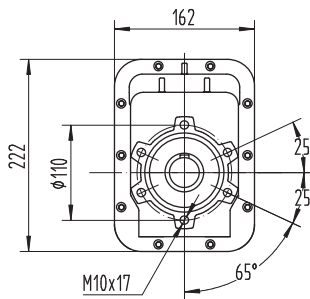
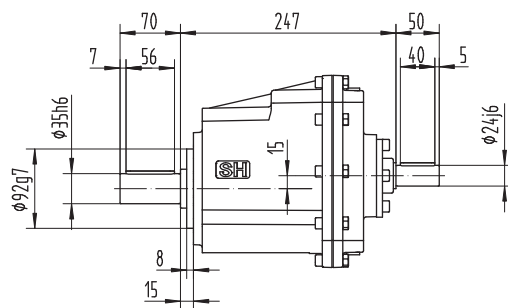

9. 安装方位和接线盒位置 / MOUNTING POSITION AND TERMINAL BOX ORIENTATION

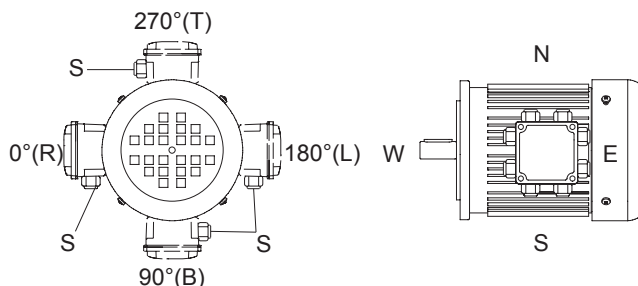
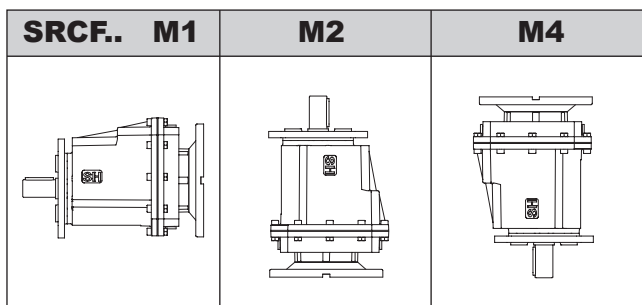
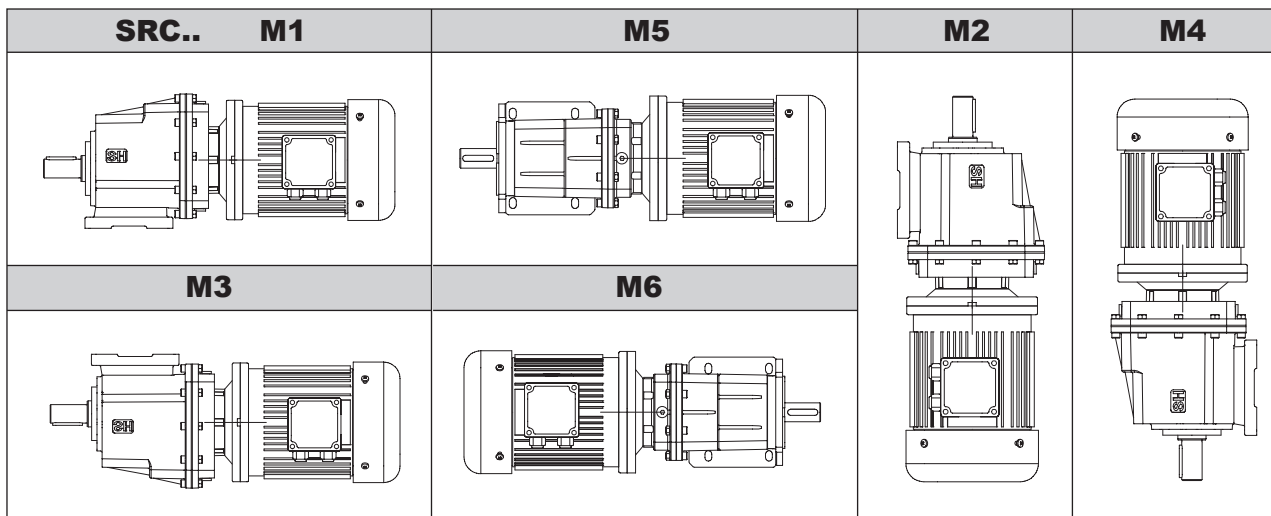

10. 润滑油添加量 / Lubricant fill quantity

减速器型号 Gear units	加注量 Fill quantity in liters						单位 unit: 升(L)
	M1	M2	M3	M4	M5	M6	
SRC..01..	0.4	0.6	0.4	0.3	0.3	0.3	
SRC..02..	0.5	0.7	0.5	0.4	0.4	0.4	
SRC..03..	0.8	1.1	0.8	0.6	0.6	0.6	
SRC..04..	1.2	1.6	1.0	1.0	0.9	0.9	

表格规定的加注量为参考值，准确值的变化与传动比有关。SRC系列减速器在出厂前已加注了长寿命的润滑油，可长期使用，一般不需要换油。

The fill quantity in the table is referenced, the exact value relating to the ratio. All SRC Series helical gear units are filled with life lubrication before delivery, do not need to change it in general.



台州机械有限公司

TAIZHOU MACHINE CO., LTD

Building 2, Room 1419, Ocean Plaza, Jiaojiang
district, Taizhou, Zhejiang, China

Phone: +86 136 6643 9613

Email: info@moktrans.com

Web: www.moktrans.com