

DS

SONSUZ VİDALI REDÜKTÖRLER WORM GEAR UNITS

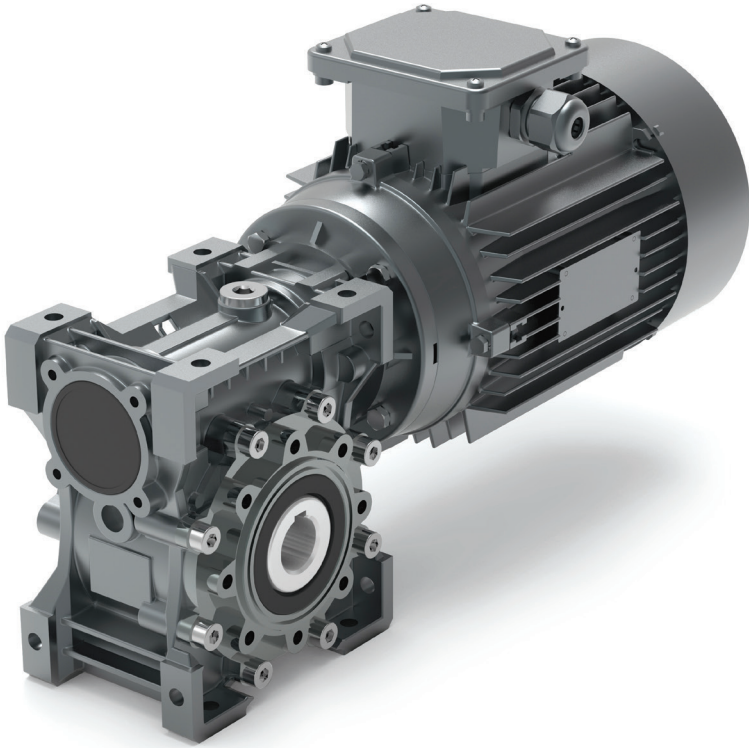





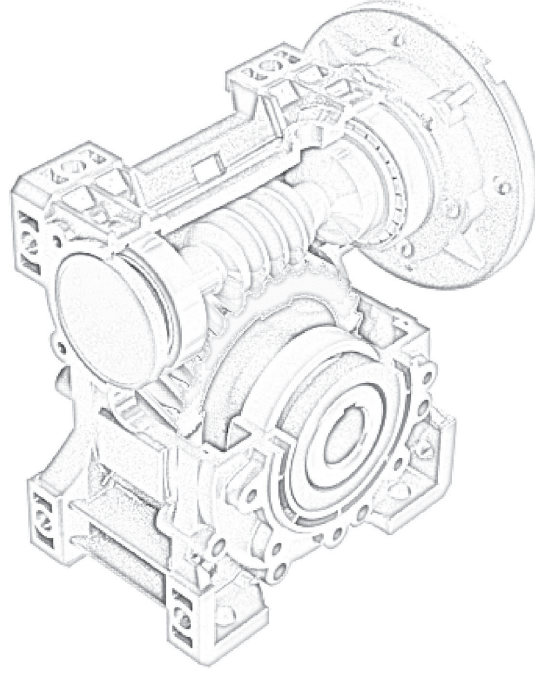



 **dinamik**
motor redüktör

TEKNİK KATALOG
TECHNICAL CATALOGUE



TR EN

İÇİNDEKİLER / CONTENTS

Servis Faktörü / Service Factor	2
Radyal Yükler / Radial Loads	3
Yağlama / Lubrication	4
Montaj / Installation	5
Montaj Pozisyonu / Mounting Positions	6
Motor Bağlantı Tablosu / Motor Connection Table	7
Güç Devir Tabloları / Geared Performance Tables	9
Ölçü Sayfaları / Dimension Pages	
 - DS	27
 - DS / PC	37
 - DY-VS	38
 - DYV-VS	39
 - DS / DS	40
 - DS / DSV	41
 - DY / DY	42
 - DY / DYV	43
Çıkış Mili / Output Shaft	44
Tork Kolu / Torque Arm	45

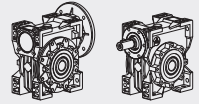

(TR) SERVİS FAKTÖRÜ

Servis faktörü (f_B), redüktörün maruz kaldığı çalışma koşullarına göre değişkenlik gösterir. En etkin servis faktörünü seçmek için göz alınması gereken parametreler aşağıdaki hususlara bağlıdır :

- Çalışan makinalardaki yükün tipi **U-M-H**
- Günlük çalışma süresi : **saat / gün**
- Start-Stop Sıklığı: **adet / saat**

Yük Tipi

U - Uniform Yükleler	$mfa \leq 0.3$
M - Orta Seviyeli Şoklar	$mfa \leq 3$
H - Ağır Şoklar	$mfa \leq 10$

$$mfa = \frac{J_e}{J_m}$$

Formülde ;

mfa : mfa atalet faktörü

Je : Tahrik milindeki indirgenmiş harici atalet 2 momenti (kgm)

Jm : Motor atalet momenti 2 (kgm)

Eğer mfa değeri > 10 ise durumu teknik servisimize bildiriniz.

U - Hafif malzemeler için vida besleme aparatları, fanlar, montaj hatları hafif malzemeler naklinde kullanılan kemerler, küçük mikserler, lifler, temizleme makinaları, dolgu makinaları, kontrol makinaları.

M - Helezonlar, ağaç işleme makinaları, besleme aparatları, malzeme lift makinaları, balans makinaları, pafta makinaları, orta boy mikserler, ağır malzeme naklinde kullanılan kemerler, vinçler, raylı kapılar, suni gübre spalutası, paketleme makinaları, beton mikserleri, vinç mekanizmaları, freze makinaları, bükme-kıvrırma makinaları, dişli pompalar.

H - Ağır malzemeler için mikserler, kırkma makası, presler, santrifüj makinaları, ayna destek aparatları, ağır malzemeler için lift ve vinçler, taşlama tezgahları, bileme taşları, pistonlu asansörler, matkap tezgahları, çekiç milleri, mil dirsek presleri, bükme- kıvrırma makinaları, döner levhalar, silindir variller, vibratörler, kağıt öğütücüleri

(EN) SERVICE FACTOR

The service factor (f_B), depends on the operating conditions to which the reduction unit is subjected correctly. The parameters that need to be taken into consideration to select the most adequate service factor comprise:

- Type of load of the operated machine: **U-M-H**
- Length of daily operating time : **hours / day**
- Start-up frequency : **starts / hours**

Type Of Load

U - Uniform	$mfa \leq 0.3$
M - Moderate Shocks	$mfa \leq 3$
H - Heavy Shocks	$mfa \leq 10$

$$mfa = \frac{J_e}{J_m}$$

Where ;

mfa : mfa factor of inertia

Je : moment of reduced external inertia at the driveshaft (kgm)

Jm : moment of inertia of motor 2 (kgm)

If mfa > 10 call our technical service.

U - Screw feeders for light materials, fans assembly lines, conveyor belts for light materials, small mixers, lifts, cleaning machines, fillers, control machines.

M - Winding devices, woodworking machine feeders, goods lifts, balancers, threading machines, medium mixers, conveyor belts for heavy materials, winches, sliding doors, fertilizer scrapers, packing machines, concrete mixers, crane mechanisms, milling cutters, folding machines, gear pumps.

H - Mixer for heavy materials, shears, presses, centrifuges, rotating supports, winches and lifts for heavy materials, grinding lathes, stone mills, bucket elevators, drilling machines, hammer mills, cam presses, folding machines, turntables, tumbling barrels, vibrators, shredders.

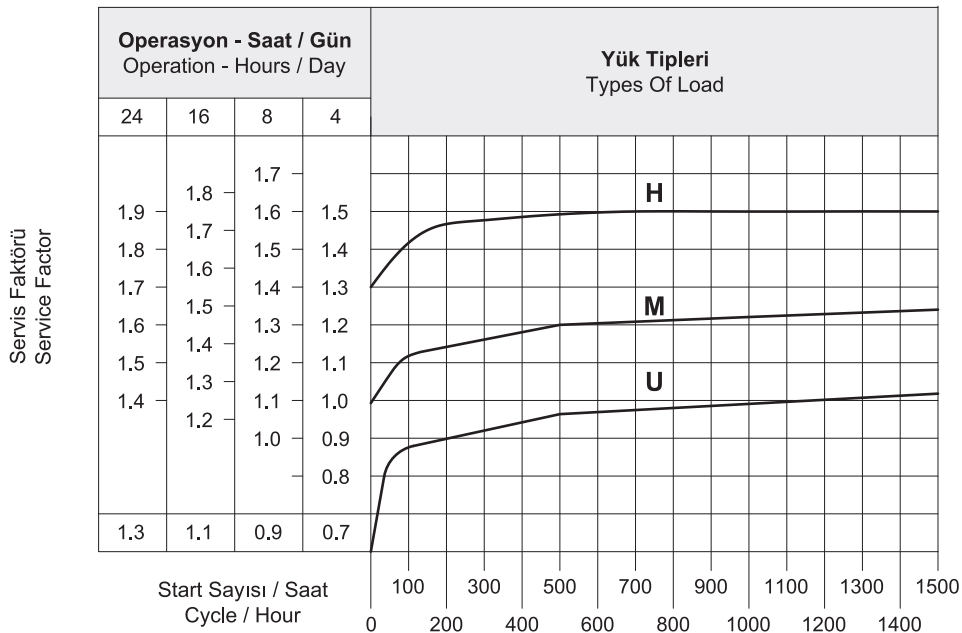

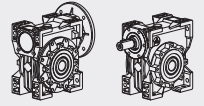

(TR) RADYAL YÜKLER

Şaft üzerindeki radyal yük aşağıdaki formülle hesaplanır.

$$F_{re} = \frac{2000 \cdot M \cdot fz}{D} \leq F_R^1 \text{ o } F_R^2$$

Formülde ;

- F_{re}** : Sonuçtaki radyal yük (N)
M : Şaft üzerindeki radyal yük (Nm)
D : Şarf üzerine monte edilmiş transmisyon elemanın çapı (mm)
F_R : Uygulanan maksimum radyal yük değeri (N) (Tablo 2.)
fz :
- 1,1 Dişliler
 - 1,4 Dişli Zinciri
 - 1,7 V-Makarası
 - 2,5 Düz Makara

Sonuç radyal yük şaftın merkez hattına uygulanmadığında aşağıdaki formülle etkin yükün hesaplanması gerekir:

$$F_{re} \leq \frac{F_R \cdot a}{(b+x)} \leq F_R^1 \text{ o } F_R^2$$

a,b,x = Tablolarda verilen değerler.

Kabul edilebilir radyal yük (N) değeri reduktörün performansını gösteren ilgili tablolarda verilmiştir. Bu durumda şaftın merkez hattına binen yük ve en uygunsuz durumlarda uygulama açısı ve yönü ile ilgili bir olgudur. Kombinasyonlu uygulamalarda max. müsaade edilen eksenel yük radyal yükün 1/5'i kadar olmalıdır. Çıkış şaftları ile ilgili olduğundan bu değer çok aşılmamalıdır.

ÇIKIŞ MİLİ - OUTPUT SHAFT

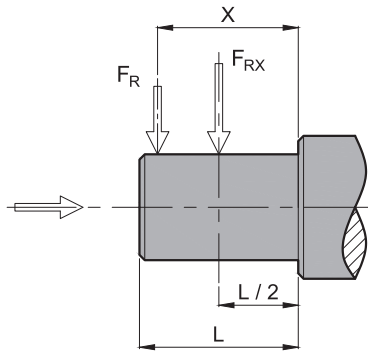

(*) Tek yönlü maksimum eksenel yük değerleri bir basma yatağı kullanılarak (talebe bağlı) kabul edilebilir. Kabul edilebilir radyal yük değerleri performansla ilgili sayfalarda verilmiştir. (F_R)

DS	a	b	F _{RMAX}
030	65	50	1830
040	84	64	3490
050	101	76	4870
063	120	95	6270
075	131	101	7380
090	162	122	8180
105	176	136	12000
110	176	136	12000
130	188	148	13500
150	215	148	18000

(EN) RADIAL LOADS

The radial load on the shaft can be calculated with the following formula:

$$F_{re} = \frac{2000 \cdot M \cdot fz}{D} \leq F_R^1 \text{ o } F_R^2$$

Where ;

- F_{re}** : Resulting radial load (N)
M : Torque on the shaft (Nm)
D : Diameter of the transmission member mounted on the shaft (mm)
F_R : Value of the maximum admitted radial load (N) (Tables 2.)
fz :
- 1,1 Gear Pinion
 - 1,4 Chain Wheel
 - 1,7 V-Pulley
 - 2,5 Flat Pulley

When the resulting radial load is not applied on the center line of the shaft is necessary to calculate the effective load with the following formula:

$$F_{re} \leq \frac{F_R \cdot a}{(b+x)} \leq F_R^1 \text{ o } F_R^2$$

a,b,x = Values are given in the tables.

The value of the admissible radial load (N) is given in the tables relating to the performance of the reduction unit at issue. It is related to the load applied on the center line of the shaft and in the most unfavorable conditions of angle of application and direction of rotation. The maximum admissible axial loads are 1/5 of the value of the given radial load.

GİRİŞ MİLİ - INPUT SHAFT

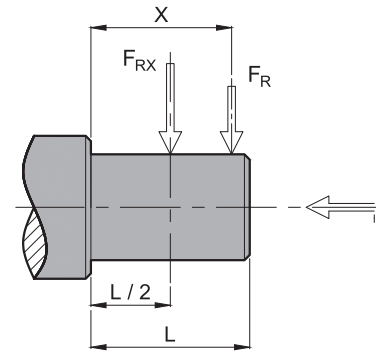

(*) Maximum axial load values admissible in only one direction with the use of a thrust bearing (on request). The values of the admissible radial loads are given on the relating to performance. (F_R)

DSV	a	b	F _{RMAX}
030	86	76	210
040	106	94,5	350
050	129	114	490
063	159	139	700
075	192	167	980
090	227	202	1270
105	266	236	1700
110	266	236	1700
130	314	274	2100
150	350	310	2800

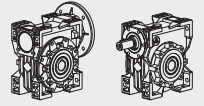

TR YAĞLAMA

Tabloda belirtilmeyen aşırı ısı ortamlarında Teknik Servisimizi arayınız. 30°C altındaki ısı değerinde veya 60°C üzerindeki bir ısı değerinde hassas özelliklere sahip yağ keçesi kullanmak gerekir. 0°C'nin altındaki sıcaklık değerlerinde çalışmak gerekiyorsa aşağıdakileri göz önünde bulundurmak gerekir.

- 1-Motorlar tahmin edilen ortam sıcaklıklarındaki operasyonlara uygunluk gerektirir.
- 2-Elektrik motorunun gücü gerekli olan yüksek başlama tork değerlerini aşabilmesi için yeterli olmalıdır.
- 3-Redüktörlerin dökme demirden imal edildiği durumlarda -15 C° sıcaklığın altında dökme demirin kırılma riski olduğundan darbe ve yüklerine özen gösterin.
- 4-Servis hizmetinin ilk aşamalarında yağın sahip olduğu aşırı akışkanlık olayından dolayı bir takım yağlama problemleri meydana gelebilir, bu durumda yüksüz olarak bir kaç dakika boyunca çalıştırmak gerekir. Yağ değişimi mineral yağlar için yaklaşık 10.000, sentetik yağlar için 20.000 saatlik kullanımdan sonra yapılmalıdır. Bu süre servis tipine ve redüktörün çalıştığı ortama göre değişir. Yağ tapalarıyla birlikte verilmeyen redüktörler için, yağlama kalıcıdır ve bu nedenle servis gerektirmez.

EN LUBRICATION

In cases of ambient temperatures not envisaged in the table, call our Technical Service. In the case of temperatures under -30°C or 60°C it is necessary to use oil seals with special properties. For operating ranges with temperatures under 0°C it is necessary to consider the following:

- 1-The motors need to be suitable operation at the envisaged ambient temperature.
- 2-The power of the electric motor needs to be adequate for exceeding the higher starting torques required.
- 3-In case of cast - iron gear reducers, pay attention to impact loads since cast iron may have problems of fragility at temperatures under -15°C.
- 4-During the early stages of service, problems of lubrication may arise due to the high level of viscosity taken on by the oil and so it is wise to have a few minutes of rotation under no load. The oil needs to be changed after approximately 10.000 hours. This period depends on the type of service and the environment where the reduction. For unit supplied without oil plugs, lubrication is permanent and so they need no servicing.

		T°C ISO SAE	AGIP	SHELL	SESSO	MOBIL	CASTROL	BP
DS110..150	Mineral Yağ Mineral Oil	(-5) / (+40) ISO VG460	BLASIA 460	OMALA OIL460	SPARTAN EP460	MOBILGEAR 634	ALPHA MAX 460	ENERGOL GR-XP460
		(-15) / (+25) ISO VG220	BLASIA 220	OMALA OIL220	SPARTAN EP220	MOBILGEAR 630	ALPHA MAX 220	ENERGOL GR-XP220
DS030..105 PC063..090	Sentetik Yağ Synthetic Oil	(-25) / (+50) ISO VG320	TELIUM VSF320	TIVELA OIL SC320	S220	GLYGOYLE 30	ALPHA MAX PG320	ENERGOL SG-XP320

•030-040-050-060-075-090 gövde tipindeki redüktörler ömür boyu yağlama gerektirmeyecek şekilde satılır. Sentetik yağ, AGIP TELIUM VSF katalogta belirtildiği gibi herhangi bir pozisyonda konumlandırılabilir. Sadece 90 ve 105 gövdelerin V5 / V6 montaj pozisyonları için kullanım şartlarını belirlemek üzere teknik servise başvurunuz.

- 110, 130 ve 150 gövdelerinde AGIP BLASIA 460 mineral yağ kullanılmaktadır.
- 110,130 ve 150 için montaj pozisyonlarını belirtmek gerekir, aksi takdirde redüktör B3 montaj pozisyonuna göre yağ miktarı ile tedarik edilir.
- Sadece 110,130 ve 150 gövde büyüklüğündeki redüktörlerde havalandırma (delikli) tapası, seviye ve yağ tapası (deliksiz) ile birlikte satılmaktadır. Montaj işleminden sonra nakliye için kullanılan havalandırma (delikli) tapası, halandırma (deliksiz) tapası ile değiştirilmesi gerekir.
- Helis dişli şekilli modüller uzun ömürlü ,sentetik yağ, AGIP TELIUM VSF ile birlikte tedarik edilir ve her türlü pozisyonda yerleştirilebilirler. Yağ işlemi ikinci kademe sonsuz redüktör dişlilerinden ayrıdır.

•The reduction in units size 030-040-050-060-075-090 are supplied complete with lifetime lubrication, synthetic oil, AGIP TELIUM VSF therefore, they can be mounted in any position envisaged in catalogue. The only exceptions are 090 and 110 in pos. V5 / V6 for which you should call our Technical Service to assess the conditions of use.

- The reduction units in size 110-130 and 150 are supplied complete with lubricant , mineral oil, AGIP BLASIA 460.
- For sizes 110-130 and 150 it is necessary to specify the position otherwise the reduction units are supplied with the quantity of oil relating to pos. B3.
- Only reduction units 110,130 and 150 are fitted with breather, level and oil drainage plugs installation after It is necessary, to replace the closed plug used for transportation with the breather plug supplied with the unit.
- The pre-stage helical modules are supplied complete with life-long lubricant, synthetic oil, AGIP TELIUM VSF, and can therefore they can be mounted in any position. Lubrication is separated from that of the worm reduction unit.

DS	030	040	050	063	075	090	110	130	150
B3							3	4.5	7
B8							2.2	3.3	5.1
B6-B7	0.04	0.08	0.15	0.3	0.55	1	2.5	3.5	5.4
V5							3	4.5	7
V6							2.2	3.3	5.1

PC	063	071	080	090
B3 - B8				
B6 - B7	0.05	0.07	0.15	0.16
V5 - V6				

Litre Cinsinden Yağ Miktarları
Oil Quantity in Litres



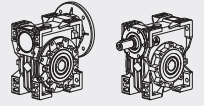

TR MONTAJ

Redüktörü monte etmek için aşağıdaki verilen tavsiyeleri uygulamanız gerekmektedir.

- Yapılacak olan montaj işleminde makinada olabilecek bir titreşimi engellemek için sabit olmalıdır.
- Cihazı makinaya monte etmeden önce redüktör çıkış şaftının dönme yönünün doğru olup olmadığını kontrol ediniz.
- Uzun süreli olarak yapılacak depolama işlemlerinde (4/6 ay) şayet yağ keçesi redüktörün içindeki yağa batık konumda değilse kauçuk parçanın şafta yapışma riski bulunduğundan veya doğru olarak alışmasını engelleyebilecek şekilde elastikliğini kaybetme riski bulunduğundan parçanın değiştirilmesini tavsiye ederiz.
- Mümkünse redüktörü güneş ışınlarından kaynaklanan radyasyondan ve kötü hava koşullarından koruyunuz.
- Fan kısmından iyi bir hava akışı sağlayarak motor soğutmasının uygun bir şekilde yapıldığından emin olunuz.
- <-5°C veya >+40°C gibi aşırı ısı değerlerinin bulunduğu ortamda Teknik Servise başvurunuz.
- Değişik parçalar (kasnaklar, dişli tekerlekler, kaplinler, şarflar), özel olarak açılmış klavuzlar kullanılarak rulman yatağı veya dış parçalarına zarar vermeyecek şekilde tasarlanmış sistemler kullanmak suretiyle hasar riski olmadan mil yada delik mili üzerine monte edilmelidir. Birbiriyle temas eden yüzeyleri aşınma veta paslanma riskine karşı yağlayınız.
- Yapılacak boya işleminde kesinlikle keçelerin alt kısımlarına nüfuz edecek şekilde veya varsa havalandırma deliklerini kapatacak şekilde olmamalıdır.
- Yağ tapası ile gönderilen redüktörlerin sevkiyat için kullanılan tapa, özel havalandırma tapası ile değiştirilmelidir.
- Mümkünse yağ seviyesini indikatörle kontrol ediniz.
- Başlatma işi, kademeli olarak (maksimum güç yüklemesine hemen geçilmeden) yapılmalıdır.
- Sınırlı düzey bile olsa yağ sızıntısı ile hasara uğrayabilecek motor altında parçalar, nesnelere veya malzemeler olması halinde bu durum için özel koruma takılmalıdır.

EN INSTALLATION

To install the reduction unit it is necessary to note the following Recommendations:

- The mounting on the machine must be stable to avoid any vibration
- In the case of particularly lengthy periods of storage (4/6 months), if the oil seal is not immersed in the lubricant inside the unit, it is recommended to change it since the rubber could stick to the shaft or may even have lost the elasticity it needs to function properly.
- Whenever possible, protect the reduction unit against direct sunlight and bad weather.
- Ensure the motor is adequately cooled by allowing proper airflow, especially from the fan side.
- In the case of ambient temperatures <-5°C or above >+40°C call the Technical Service.
- The various parts (pulleys, gear wheels, couplings, shafts, etc.) must be mounted on the solid or hollow shafts using special threaded holes or other systems that guarantee correct operation without risking damage to the bearings or external parts of the units. Lubricate the surfaces in contact to avoid seizure or oxidation.
- Painting must definitely not go over rubber parts and the holes on the breather plugs, if any.
- For units equipped with oil plugs, replace the closed plug used for shipping with the special breather plug.
- Check the correct level of the lubricant through the indicator, if there is one.
- Starting must take place gradually, without immediately applying the maximum load.
- When there are parts, objects or materials under the motor drive that can be damaged by even limited spillage of oil, special protection should be fitted.

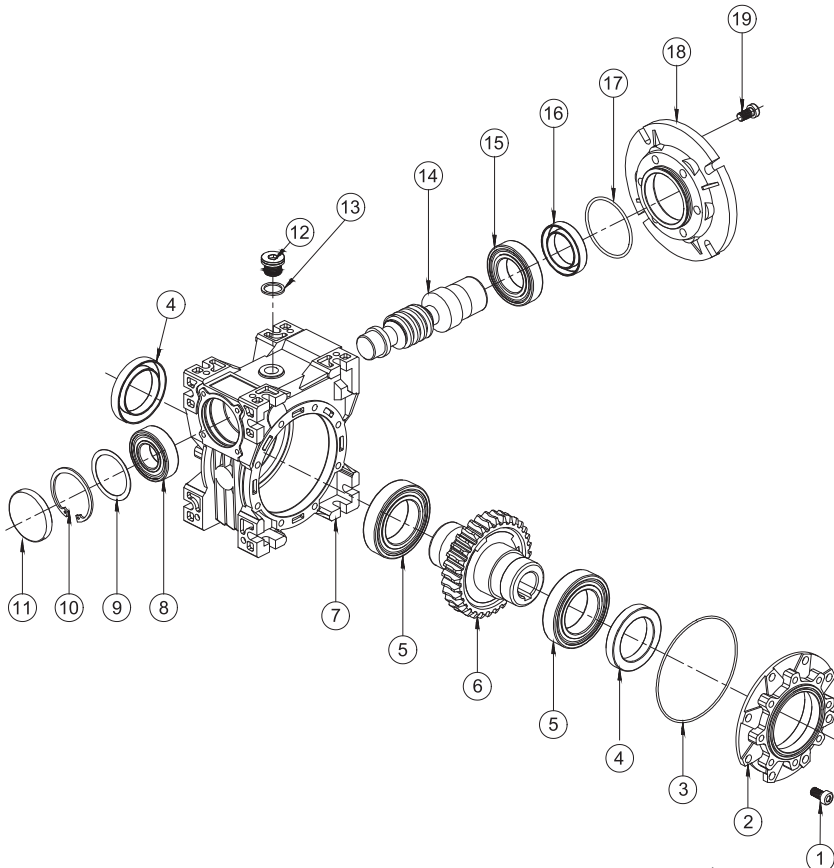

DS

01	Civata	Bolt
02	Kapak	Cover
03	O-Ring	O-Ring
04	Yağ Keçesi	Oil Seal
05	Rulman	Bearing
06	Çark	Worm Wheel
07	Gövde	Gear Case
08	Rulman	Bearing
09	Layner	Shim
10	Segman	Circlip
11	Yağ Kapağı	Oil Cover
12	Yağ Tapası	Oil Plug
13	Pul	Lamella
14	Vida	Worm Secrew
15	Rulman	Bearing
16	Yağ Keçesi	Oil Seal
17	O-Ring	O-Ring
18	Giriş Flanşı	Input Flange
19	Civata	Bolt

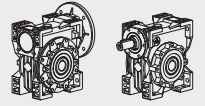

TR MONTAJ POZİSYONU

EN MOUNTING POSITIONS

DS

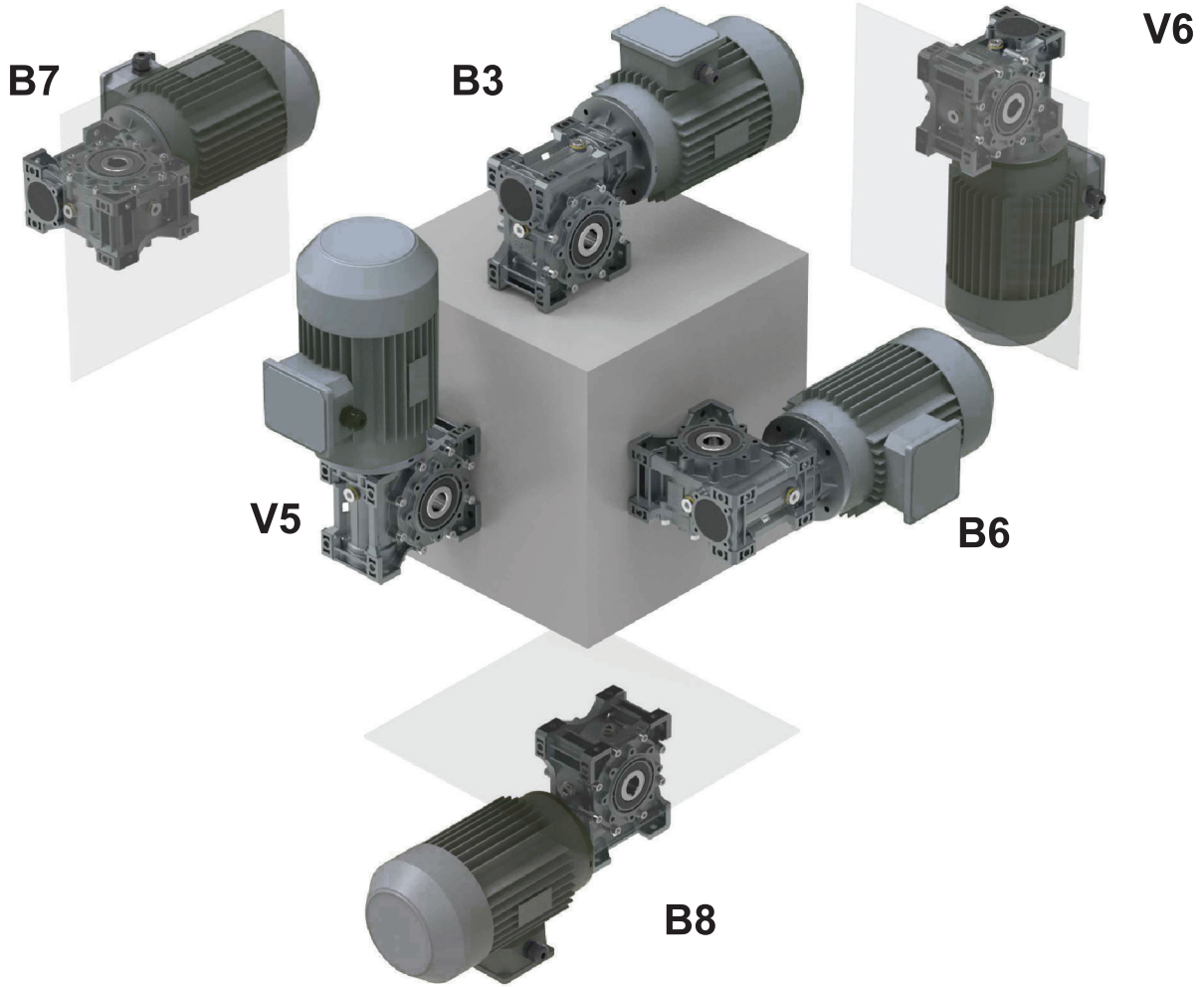

-Herhangi bir seçenek sunulmazsa standart pozisyonumuz B3'tür.

-Farklı bir pozisyon belirtildiği takdirde, Teknik Servisimize başvurmanız gerekmektedir.

-Unless specified otherwise, the standard positions are B3.
-For positions not envisaged, it is necessary to call our Technical Service.

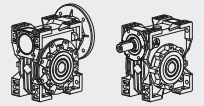

TR MOTOR BAĞLANTI TABLOSU

EN MOTOR CONNECTION TABLE

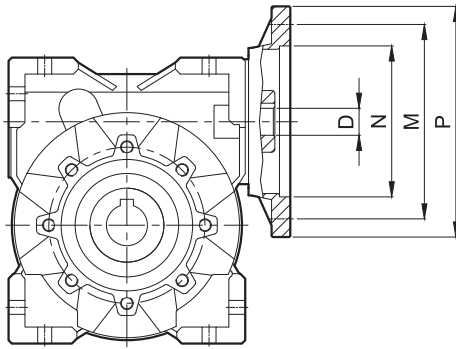

(*) Kama derinliği standart dışı.

○ Daire içindeki ölçüler standart dışı olarak üretilebilir.

(*) Low profile key supplied by Dinamik.

○ The possible diameters are shown in the circle, but they are not included in the catalogue.

DS	PAM - IEC	N	M	P	P															
					5	7.5	10	15	20	25	30	40	50	60	80					
DS030	63B5	95	115	140	11	11	11	11	11	11	11	11	11	11	11	11	-			
	63B14	60	75	90																
	56B5	80	100	120	9	9	9	9	9	9	9	9	9	9	9	9	-			
	56B14	50	65	80																
DS040	71B5	110	130	160	14	14	14	14	14	14	14	14	14	14	14	14	14	14		
	71B14	70	85	105																
	63B5	95	115	140	11	11	11	11	11	11	11	11	11	11	11	11	11	11		
	63B14	60	75	90																
	56B5	80	100	120	-	-	-	-	-	-	-	-	9	9	9	9	9	9		
DS050	80B5	130	165	200	19	19	19	19	19	19	19	19	19	19	19	19	19	19	-	
	80B14	80	100	120																
	71B5	110	130	160	14	14	14	14	14	14	14	14	14	14	14	14	14	14	14	
	71B14	70	85	105																
	63B5	95	115	140	-	-	-	-	-	-	-	11	11	11	11	11	11	11	11	
DS063	90B5	130	165	200	-	24	24	24	24	24	24	24	24	24	24	24	24	24	-	-
	90B14	95	115	140																
	80B5	130	165	200	-	19	19	19	19	19	19	19	19	19	19	19	19	19	19	
	80B14	80	100	120																
	71B5	110	130	160	-	-	-	-	-	-	-	14	14	14	14	14	14	14	14	
	71B14	70	85	105																
DS075	100/112B5	180	215	250	-	28	28	28	28	28	28	28	28	28	28	28	28	28	-	-
	100/112B14	110	130	160																
	90B5	130	165	200	-	24	24	24	24	24	24	24	24	24	24	24	24	24	24	
	90B14	95	115	140																
	80B5	130	165	200	-	-	-	-	19	19	19	19	19	19	19	19	19	19	19	
	80B14	80	100	120																
	71B5	110	130	160	-	-	-	-	-	-	-	-	14	14	14	14	14	14	14	
71B14	70	85	105																	
DS090	100/112B5	180	215	250	-	28	28	28	28	28	28	28	28	28	28	28	28	28	-	-
	100/112B14	110	130	160																
	90B5	130	165	200	-	24	24	24	24	24	24	24	24	24	24	24	24	24	24	
	90B14	95	115	140																
	80B5	130	165	200	-	-	-	-	-	-	-	-	19	19	19	19	19	19	19	
	80B14	80	100	120																

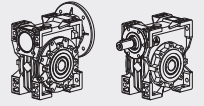

TR MOTOR BAĞLANTI TABLOSU

EN MOTOR CONNECTION TABLE

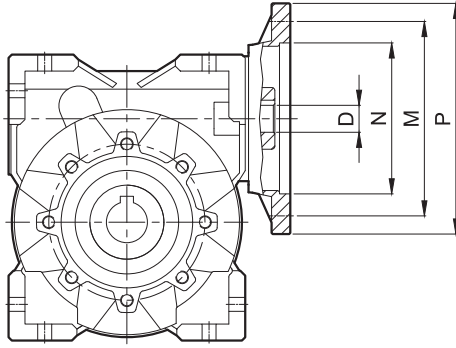

(*) Kama derinliği standart dışı.

○ Daire içindeki ölçüler standart dışı olarak üretilebilir.

(*) Low profile key supplied by Dinamik

○ The possible diameters are shown in the circle, but they are not included in the catalogue.

DS	PAM - IEC	N	M	P	P												
					5	7.5	10	15	20	25	30	40	50	60	80	100	
DS110	132B5	230	265	300	-	38	38	38	38	38	38*	38*	38*	38*	-	-	
	100/112B5	180	215	250	-	28	28	28	28	28	28	28	28	28	28	28	
	100/112B14	110	130	160	-	-	-	-	-	-	-	-	-	-	28	28	
	90B5	130	165	200	-	-	-	-	-	24	24	24	24	24	24	24	
	80B5	130	165	200	-	-	-	-	-	-	-	-	-	-	19	19	
DS130	132B5	230	265	300	-	38	38	38	38	38	38	38	38*	38*	38*	38*	
	100/112B5	180	215	250	-	-	-	-	-	28	28	28	28	28	28	28	
	100/112B14	110	130	160	-	-	-	-	-	-	-	-	-	-	24	24	
	90B5	130	165	200	-	-	-	-	-	-	-	-	-	-	24	24	
DS150	160B5	250	300	350	-	42	42	42	42	42	42	42	42	42	42	-	-
	132B5	230	265	300	-	-	-	-	38	38	38	38	38	38	38	38	38
	100/112B5	180	215	250	-	-	-	-	-	-	-	-	28	28	28	28	
	100/112B14	110	130	160	-	-	-	-	-	-	-	-	28	28	28	28	



GÜÇ DEVİR TABLOLARI

GEARED PERFORMANCE TABLES

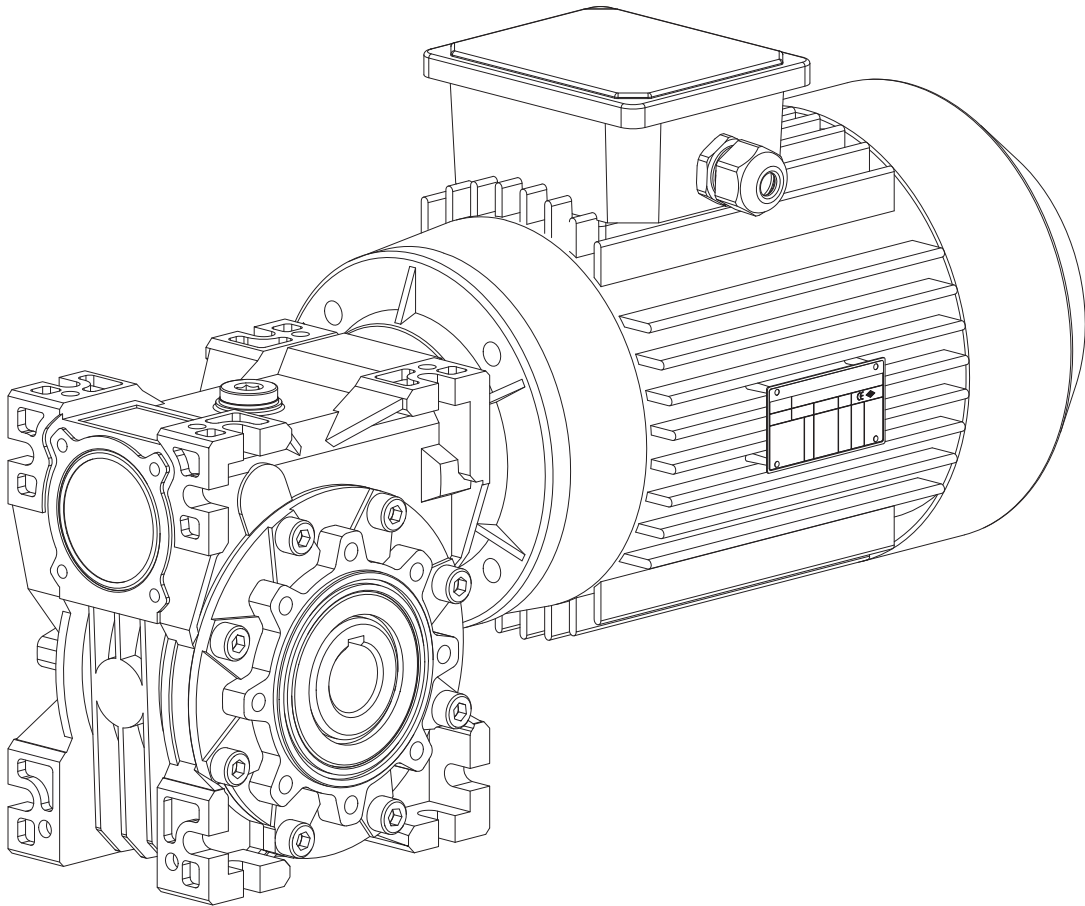

GÜÇ DEVİR TABLOLARI

GEARED PERFORMANCE TABLES

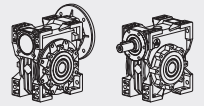

Motor Gücü Motor Power P_1 (kW)	Çıkış Devri Output Speed n_2 (min^{-1})	Çıkış Momenti Output Torque M_2 (Nm)	Servis Faktörü Service Factor f_B	Tahvil Oranı Ratio i_{ges}	Radyal Yük Radial Force F_R (N)	Tip Type
0.09	560.0	1.4	8.8	5	474	DS030 56M2A
	373.3	2.0	6.5	7.5	542	
	280.0	2.6	5.0	10	597	
	186.7	3.7	3.5	15	683	
	140.0	4.8	2.5	20	752	
	112.0	5.7	2.8	25	810	
	93.3	6.5	2.3	30	861	
	70.0	8.1	1.7	40	948	
	56.0	10	1.4	50	1021	
	46.7	11	1.1	60	1085	
	35.0	13	0.9	80	1194	
	280.0	2.7	6.7	5	597	DS030 56M4B
	186.7	3.9	4.6	7.5	683	
	140.0	5.0	3.6	10	752	
	93.3	7.1	2.5	15	861	
	70.0	9.0	2.0	20	948	
	56.0	10	2.0	25	1021	
	46.7	12	1.7	30	1085	
	35.0	14	1.2	40	1194	
	28.0	17	1.0	50	1286	
	23.3	19	0.9	60	1367	
	28.0	19	2.0	50	2475	DS040 56M4B
	23.3	21	1.7	60	2630	
	17.5	26	1.3	80	2895	
	14.0	29	1.0	100	3118	
	4.7	88	0.8	300	3490	DS040 / 030 56M4B
	3.5	107	1.2	400	4840	DS050 / 030 56M4B
	2.8	123	1.0	500	4840	
	2.3	159	0.9	600	4840	
	1.9	185	0.8	750	4840	
	1.6	212	0.7	900	4840	
	1.6	200	1.0	900	6270	DS063 / 030 56M4B
	1.2	263	0.9	1200	6270	
	0.93	305	0.7	1500	6270	
	0.9	360	1.1	1500	7380	DS075 / 040 56M4B
	0.78	404	1.0	1800	7380	
0.58	496	0.7	2400	7380		
0.5	609	0.9	3000	8180	DS090 / 040 56M4B	
0.35	548	0.8	4000	8180		
0.12	280.0	2.7	6.7	5	597	DS030 63M4A
	186.7	3.9	4.6	7.5	683	
	140.0	5.0	3.6	10	752	
	93.3	7.1	2.5	15	861	
	70.0	9.0	2.0	20	948	
	56.0	10	2.0	25	1021	
	46.7	12	1.7	30	1085	
	35.0	14	1.2	40	1194	
	28.0	17	1.0	50	1286	
	46.7	17	2.6	30	2087	
	35.0	21	1.9	40	2298	
	28.0	25	1.5	50	2475	
	23.3	28	1.3	60	2630	
	17.5	34	1.0	80	2895	
	14.0	38	0.8	100	3118	
	18.7	42	1.2	75	2833	DS040 / PC063 63M4A
	15.6	46	1.2	90	3011	
	11.7	57	0.9	120	3314	

GÜÇ DEVİR TABLOLARI

GEARED PERFORMANCE TABLES

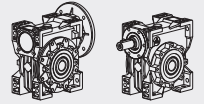

Motor Gücü Motor Power P_1 (kW)	Çıkış Devri Output Speed n_2 (min^{-1})	Çıkış Momenti Output Torque M_2 (Nm)	Servis Faktörü Service Factor f_B	Tahvil Oranı Ratio i_{ges}	Radyal Yük Radial Force F_R (N)	Tip Type
0.12	18.7	42	1.2	75	2833	DS040 / PC063 63M4A
	15.6	46	1.2	90	3011	
	11.7	57	0.9	120	3314	
	9.3	66	0.7	150	3490	
	7.8	74	0.6	180	3490	
	23.3	29	2.3	60	3610	DS050 63M4A
	17.5	35	1.9	80	3973	
	14.0	40	1.4	100	4280	
	9.3	68	1.3	150	4840	DS050 / PC063 63M4A
	7.8	75	1.1	180	4840	
	5.8	88	0.8	240	4840	
	4.7	98	0.7	300	4840	
	4.7	119	1.2	300	4840	DS050 / 030 63M4A
	3.5	142	0.9	400	4840	
	2.8	164	0.7	500	4840	
	5.8	92	1.5	240	6270	DS063 / PC063 63M4A
	4.7	103	1.2	300	6270	
	2.8	171	1.3	500	6270	DS063 / 030 63M4A
	2.3	208	1.1	600	6270	
	1.9	241	0.9	750	6270	
	1.6	325	1.2	900	7380	DS075 / 040 63M4A
	1.2	399	0.9	1200	7380	
	0.8	547	0.9	1800	8180	DS090 / 040 63M4A
	0.58	695	0.8	2400	8180	
0.5	884	1.1	3000	10320	DS110 / 050 63M4A	
0.35	784	1.0	4000	10320		
0.28	928	0.76	5000	10320		
0.18	560.0	2.7	4.4	5	474	DS030 63M2A
	373.3	4.0	3.2	7.5	542	
	280.0	5.2	2.5	10	597	
	186.7	7.5	1.7	15	683	
	140.0	10	1.3	20	752	
	112.0	11	1.4	25	810	
	93.3	13	1.1	30	861	
	70.0	16	0.9	40	948	
	280.0	5.3	3.4	5	597	DS030 63M4B
	186.7	7.8	2.3	7.5	683	
	140.0	10	1.8	10	752	
	93.3	14	1.3	15	861	
	70.0	18	1.0	20	948	
	56.0	21	1.0	25	1021	
	46.7	24	0.8	30	1085	
	93.3	14	2.4	30	1657	DS040 63M2A
	70.0	18	1.8	40	1824	
	56.0	21	1.4	50	1964	
	70.0	19	2.0	20	1824	DS040 63M4B
	56.0	23	1.7	25	1965	
	46.7	26	1.7	30	2087	
	35.0	32	1.3	40	2298	
	28.0	38	1.0	50	2475	
	23.3	43	0.8	60	2630	
45.0	29	1.5	20	2113	DS040 71M6A	
36.0	34	1.3	25	2276		
30.0	38	1.3	30	2419		
22.5	47	1.0	40	2662		



GÜÇ DEVİR TABLOLARI

GEARED PERFORMANCE TABLES

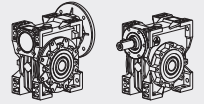

Motor Gücü Motor Power P_1 (kW)	Çıkış Devri Output Speed n_2 (min^{-1})	Çıkış Momenti Output Torque M_2 (Nm)	Servis Faktörü Service Factor f_B	Tahvil Oranı Ratio i_{ges}	Radyal Yük Radial Force F_R (N)	Tip Type
0.18	18.7	64	0.8	75	2833	DS040 / PC063 63M4B
	15.6	70	0.8	90	3011	
	11.7	85	0.8	120	3314	
	46.7	24	2.1	60	2865	DS050 63M2A
	35.0	30	1.5	80	3153	
	28.0	34	1.2	100	3397	
	35.0	33	2.3	40	3153	DS050 63M4B
	28.0	39	1.9	50	3397	
	23.3	43	1.6	60	3610	
	17.5	52	1.2	80	3973	
	14.0	60	0.9	100	4280	
	18.0	56	1.4	50	3936	DS050 71M6A
	15.0	63	1.1	60	4183	
	11.0	75	0.9	80	4604	
	18.7	64	1.4	75	3889	DS050 / PC063 63M4B
	15.6	71	1.5	90	4132	
	11.7	87	1.1	120	4548	
	9.3	101	0.9	150	4840	
	7.8	113	0.7	180	4840	
	5.8	133	0.6	240	4840	
	12.0	95	1.2	75	4506	DS050 / PC071 71M6A
	10.0	105	1.4	90	4788	
	7.5	126	1.0	120	4840	
	15.0	66	2.1	60	5467	DS063 71M6A
	11.3	79	1.6	80	6018	
	9.0	90	1.4	100	6270	
	9.3	103	1.7	150	6270	DS063 / PC063 63M4B
	7.8	117	1.4	180	6270	
	5.8	139	1.0	240	6270	
	4.7	155	0.8	300	6270	
12.0	97	2.2	75	5889	DS063 / PC071 71M6A	
10.0	107	2.4	90	6259		
7.5	131	1.8	120	6270		
6.0	152	1.4	150	6270		
5.0	168	1.2	180	6270		
3.8	197	0.9	240	6270		
3.0	218	0.7	300	6270		
3.5	222	1.0	400	6270	DS063 / 030 63M4B	
2.8	257	0.8	500	6270		
5.0	179	1.7	180	7380	DS075 / PC071 71M6A	
3.8	211	1.2	240	7380		
3.0	235	1.0	300	7380		
2.3	362	1.1	600	7380	DS075 / 040 - 63M4B	
1.9	435	0.9	750	7380		
1.6	487	0.8	900	7380		
1.2	629	1.0	1200	8180	DS090 / 040 - 63M4B	
0.93	735	0.8	1500	8180		
0.8	861	1.5	1800	10320	DS110 / 050 - 63M4B	
0.58	1113	1.1	2400	10320		
0.25	560.0	3.8	3.2	5	474	DS030 63M2B
	373.3	5.6	2.3	7.5	542	
	280.0	7.2	1.8	10	597	
	186.7	10	1.3	15	683	
	140.0	13	0.9	20	752	
	112.0	16	1.0	25	810	
	93.3	18	0.8	30	861	

GÜÇ DEVİR TABLOLARI

GEARED PERFORMANCE TABLES

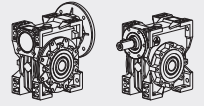

Motor Gücü Motor Power P_1 (kW)	Çıkış Devri Output Speed n_2 (min^{-1})	Çıkış Momenti Output Torque M_2 (Nm)	Servis Faktörü Service Factor f_B	Tahvil Oranı Ratio i_{ges}	Radyal Yük Radial Force F_R (N)	Tip Type
0.25	280.0	8	4.5	5	1149	DS040 71M4A
	186.7	11	3.6	7.5	1315	
	140.0	14	2.8	10	1447	
	93.3	21	1.9	15	1657	
	70.0	27	1.5	20	1824	
	56.0	32	1.2	25	1964	
	46.7	36	1.3	30	2087	
	35.0	44	0.9	40	2298	
	180.0	12	3.5	5	1331	DS040 71M6B
	120.0	17	2.6	7.5	1524	
	90.0	22	2.0	10	1677	
	60.0	31	1.4	15	1920	
	45.0	40	1.1	20	2113	
	36.0	48	0.9	25	2276	
	30.0	53	0.9	30	2419	
	35.0	42	1.1	80	3153	DS050 63M2B
	28.0	48	0.8	100	3397	
	70.0	27	2.7	20	2503	DS050 71M4A
	56.0	32	2.2	25	2696	
	46.7	37	2.3	30	2865	
	35.0	46	1.7	40	3153	
	28.0	54	1.4	50	3397	
	23.3	60	1.1	60	3610	
	17.5	72	0.9	80	3973	
	45.0	40	1.9	20	2900	DS050 71M6B
	36.0	48	1.5	25	3124	
	30.0	54	1.7	30	3320	
	22.5	67	1.2	40	3654	
	18.0	78	1.0	50	3936	
	15.0	88	0.8	60	4183	
	18.7	88	1.0	75	3889	DS050 / PC071 71M4A
	15.6	98	1.1	90	4132	
	11.7	121	0.8	120	4548	
	28.0	56	2.4	50	4440	DS063 71M4A
	23.3	63	2.0	60	4719	
	17.5	78	1.6	80	5193	
	14.0	87	1.4	100	5595	
	18.0	81	1.8	50	5145	DS063 71M6B
	15.0	92	1.5	60	5467	
	11.3	110	1.2	80	6018	
	9.0	125	1.0	100	6270	
	18.7	91	1.8	75	5083	DS063 / PC071 71M4A
15.6	100	2.0	90	5401		
11.7	125	1.5	120	5945		
9.3	143	1.2	150	6270		
7.8	163	1.0	180	6270		
5.8	192	0.7	240	6270		
4.7	215	0.6	300	6270		
12.0	81	1.6	75	5889	DS063 / PC071 71M6B	
10	92	1.8	90	6259		
7.5	110	1.3	120	6270		
6	125	1.0	150	6270		
7.0	159	1.4	80	6130	DS063 / 030 63M2B	
5.6	185	1.2	100	6603		
17.5	82	2.3	400	6130	DS075 71M4A	
14.0	94	1.9	500	6603		



GÜÇ DEVİR TABLOLARI

GEARED PERFORMANCE TABLES

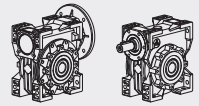

Motor Gücü Motor Power P_1 (kW)	Çıkış Devri Output Speed n_2 (min^{-1})	Çıkış Momenti Output Torque M_2 (Nm)	Servis Faktörü Service Factor f_B	Tahvil Oranı Ratio i_{ges}	Radyal Yük Radial Force F_R (N)	Tip Type
0.25	11.3	117	1.7	80	7103	DS075 71M6B
	9.0	133	1.4	100	7380	
	9.3	151	1.7	150	7380	DS075 / PC071 71M4A
	7.8	172	1.4	180	7380	
	5.8	201	1.1	240	7380	
	4.7	230	0.9	300	7380	
	12.0	139	2.4	75	6952	DS075 / PC071 71M6B
	10.0	155	2.5	90	7380	
	7.5	191	1.9	120	7380	
	6.0	219	1.5	150	7380	
	5.0	248	1.2	180	7380	
	3.5	336	1.1	400	7380	DS075 / 040 71M4A
	2.8	384	0.8	500	7380	
	5.0	263	1.9	180	8180	DS090 / PC071 71M6B
	3.8	318	1.4	240	8180	
	3.0	358	1.1	300	8180	
	2.3	512	1.2	600	10320	DS090 / 040 71M4A
	1.9	598	0.9	750	10320	
1.6	667	0.8	900	10320		
1.2	943	1.3	1200	10320	DS110 / 050 71M4A	
0.93	1064	1.2	1500	10320		
0.78	1195	1.1	1800	10320		
0.6	1624	1.0	2400	13500	DS130 / 063 - 71M4A	
0.47	1935	0.8	3000	13500		
0.35	2046	0.6	4000	13500		
0.28	2430	0.5	5000	13500		
0.8	1199	1.8	1800	18000	DS150 / 063 71M4A	
0.6	1446	1.8	2400	18000		
0.5	1713	1.4	3000	18000		
0.4	2026	0.9	4000	18000		
0.3	2251	0.7	5000	18000		
0.37	560.0	5.7	4.2	5	912	DS040 71M2A
	373.3	8.4	3.3	7.5	1044	
	280.0	11	2.6	10	1149	
	186.7	16	1.9	15	1315	
	140.0	21	1.4	20	1447	
	112.0	25	1.1	25	1559	
	280.0	11	3.0	5	1149	DS040 71M4B
	186.7	16	2.4	7.5	1315	
	140.0	21	1.9	10	1447	
	93.3	31	1.3	15	1657	
	70.0	39	1.0	20	1824	
	56.0	47	0.8	25	1964	
	93.3	31	1.3	15	1657	
	70.0	39	1.0	20	1824	
	56.0	47	0.8	25	1964	
	46.7	53	0.8	30	2087	
	112.0	25	2.0	25	2140	DS050 71M2A
	93.3	29	2.2	30	2274	
70.0	37	1.6	40	2503		
56.0	44	1.2	50	2696		

GÜÇ DEVİR TABLOLARI

GEARED PERFORMANCE TABLES

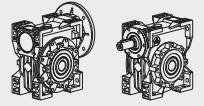

Motor Gücü Motor Power P_1 (kW)	Çıkış Devri Output Speed n_2 (min^{-1})	Çıkış Momenti Output Torque M_2 (Nm)	Servis Faktörü Service Factor f_B	Tahvil Oranı Ratio i_{ges}	Radyal Yük Radial Force F_R (N)	Tip Type
0.37	46.7	50	1.0	60	2865	DS050 71M2A
	35.0	62	0.7	80	3153	
	140.0	22	3.3	10	1987	DS050 71M4B
	93.3	31	2.4	15	2274	
	70.0	40	1.8	20	2503	
	56.0	48	1.5	25	2696	
	46.7	55	1.5	30	2865	
	35.0	68	1.1	40	3153	
	28.0	80	0.9	50	3397	
	23.3	89	0.8	60	3610	
	180.0	17	4.3	5	1827	DS050 80M6A
	120.0	25	3.3	7.5	2091	
	90.0	33	2.5	10	2302	
	60.0	47	1.8	15	2635	
	45.0	60	1.3	20	2900	
	36.0	72	1.0	25	3124	
	30.0	80	1.1	30	3320	
	35.0	71	2.1	40	4122	DS063 71M4B
	28.0	83	1.6	50	4440	
	23.3	94	1.4	60	4719	
	17.5	115	1.1	80	5193	
	14.0	129	0.9	100	5595	
	45.0	60	2.4	20	3791	DS063 80M6A
	36.0	74	1.9	25	4084	
	30.0	82	2.1	30	4339	
	22.5	102	1.6	40	4776	
	18.0	120	1.2	50	5145	
	15.0	137	1.0	60	5467	
	18.7	134	1.2	75	5083	DS063 / PC071 71M4B
	15.6	148	1.4	90	5401	
	11.7	165	1.0	120	5945	
	9.3	212	0.8	150	6270	
	23.3	98	2.0	60	5569	DS075 71M4B
	17.5	121	1.6	80	6130	
	14.0	139	1.3	100	6603	
	18.0	126	1.8	50	6073	DS075 80M6A
15.6	144	1.5	60	6375		
11.3	173	1.2	80	7103		
9.0	196	1.0	100	7380		
18.7	138	1.8	75	6000	DS075 / PC071 71M4B	
15.6	154	1.9	90	6375		
11.7	191	1.5	120	7017		
9.3	223	1.1	150	7380		
7.8	254	0.9	180	7380		
12.0	206	1.6	75	6952		DS075 / PC080 80M6A
10.0	230	1.7	90	7380		
7.5	283	1.3	120	7380		
6.0	324	1.0	150	7380		
4.7	405	1.0	300	7380	DS075 / 040 71M4B	
3.5	498	0.7	400	7380		
11.3	185	1.7	80	7859	DS090 80M6A	
9.0	212	1.3	100	8180		
7.8	268	1.5	180	8180	DS090 / PC071 71M4B	
5.8	321	1.1	240	8180		
4.7	371	0.9	300	8180		



GÜÇ DEVİR TABLOLARI

GEARED PERFORMANCE TABLES

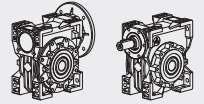

Motor Gücü Motor Power P_1 (kW)	Çıkış Devri Output Speed n_2 (min^{-1})	Çıkış Momenti Output Torque M_2 (Nm)	Servis Faktörü Service Factor f_B	Tahvil Oranı Ratio i_{ges}	Radyal Yük Radial Force F_R (N)	Tip Type
0.37	6.0	347	1.6	150	8180	DS090 / PC080 80M6A
	5.0	389	1.3	180	8180	
	3.8	471	1.0	240	8180	
	4.7	402	1.5	300	8180	DS090 / 040 71M4B
	3.5	523	1.2	400	8180	
	2.8	611	0.9	500	8180	
	2.3	757	0.8	600	8180	
	3.8	509	1.6	240	10320	DS0110 / PC080 80M6A
	3.0	577	1.3	300	10320	
	1.9	950	1.3	750	10320	DS110 / 050 71M4B
	1.6	1079	1.2	900	10320	
	1.2	1396	0.8	1200	10320	
	0.9	1674	1.1	1500	13500	DS130 / 063 71M4B
	0.78	1887	0.9	1800	13500	
0.8	1775	1.2	1800	18000	DS063 / 150 - 71M/4B	
0.6	2141	1.2	2400	18000		
0.5	2535	0.9	3000	18000		
0.55	560.0	8.4	2.8	5	912	DS040 71M2B
	373.3	13	2.2	7.5	1044	
	280.0	17	1.8	10	1149	
	186.7	24	1.3	15	1315	
	140.0	31	0.9	20	1447	
	112.0	37	0.8	25	1559	
	280.0	17	2.0	5	1149	DS040 71M4C
	186.7	24	1.6	7.5	1315	
	140.0	32	1.3	10	1447	
	93.3	46	0.9	15	1657	
	140.0	8.4	1.7	20	1987	DS050 71M2B
	112.0	13	1.4	25	2140	
	93.3	17	1.5	30	2274	
	70.0	24	1.1	40	2503	
	56.0	31	0.8	50	2696	
	46.7	37	0.7	60	2865	
	280.0	11	3.0	5	1149	DS050 80M4A
	186.7	16	2.4	7.5	1315	
	140.0	21	1.9	10	1447	
	93.3	31	1.3	15	1657	
	70.0	39	1.0	20	1824	
	56.0	47	0.8	25	1964	
	46.7	53	0.8	30	2087	
	120.0	38	2.2	7.5	2091	DS050 80M6B
	90.0	49	1.7	10	2302	
	60.0	69	1.2	15	2635	
	45.0	89	0.9	20	2900	
70.0	56	1.9	40	3272	DS063 71M2B	
56.0	67	1.5	50	3524		
46.7	77	1.2	60	3745		
35.0	95	0.9	80	4122		
28.0	109	0.7	100	4440		
70.0	61	2.2	20	3272	DS063 80M4A	
56.0	73	1.8	25	3524		
46.7	83	1.9	30	3745		
35.0	105	1.4	40	4122		
28.0	124	1.1	50	4440		
23.3	140	0.9	60	4719		

GÜÇ DEVİR TABLOLARI

GEARED PERFORMANCE TABLES

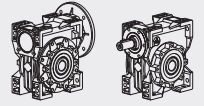

Motor Gücü Motor Power P_1 (kW)	Çıkış Devri Output Speed n_2 (min^{-1})	Çıkış Momenti Output Torque M_2 (Nm)	Servis Faktörü Service Factor f_B	Tahvil Oranı Ratio i_{ges}	Radyal Yük Radial Force F_R (N)	Tip Type
0.55	60.0	71	2.2	15	3444	DS063 80M6B
	45.0	90	1.6	20	3791	
	36.0	109	1.3	25	4084	
	30.0	123	1.4	30	4339	
	22.5	152	1.1	40	4776	
	18.7	200	0.8	75	5083	DS063 / PC071 71M4C
	15.6	219	0.9	90	5401	
	35.0	108	2.0	40	4865	DS075 80M4A
	28.0	129	1.6	50	5241	
	23.3	146	1.4	60	5569	
	17.5	180	1.1	80	6130	
	14.0	206	0.9	100	6603	
	30.0	128	2.0	30	5122	DS075 80M6B
	22.5	159	1.5	40	5637	
	18.0	187	1.2	50	6073	
	15.0	214	1.0	60	6453	
	18.7	205	1.2	75	6000	DS075 / PC071 71M4C
	15.6	230	1.3	90	6375	
	11.7	284	1.0	120	7017	
	18.7	205	1.2	75	6000	DS075 / PC080 80M4A
	15.6	230	1.3	90	6375	
	11.7	284	1.0	120	7017	
	9.3	332	0.8	150	7380	
	12.0	306	1.1	75	6952	DS075 / PC080 80M6B
	10.0	341	1.1	90	7380	
	17.5	189	1.5	80	6783	DS090 80M4A
	14.0	221	1.2	100	7306	
	18.0	198	2.0	50	6719	DS090 80M6B
	15.0	224	1.6	60	7140	
	11.3	275	1.1	80	7859	
	9.0	315	0.9	100	8180	
	15.6	240	2.3	90	7054	DS090 / PC080 - 80M4A
	11.7	297	1.6	120	7764	
	9.3	355	1.3	150	8180	
	7.8	398	1.0	180	8180	
	10.0	357	2.0	90	8174	DS090 / PC080 80M6B
7.5	441	1.4	120	8180		
6.0	516	1.1	150	8180		
5.0	578	0.9	180	8180		
9.3	306	2.0	300	8180	DS090 / 040 71M2B	
7.0	403	1.5	400	8180		
5.6	470	1.2	500	8180		
17.5	201	2.6	80	8571	DS110 80M4A	
14.0	236	2.0	100	9232		
11.3	294	1.9	80	9931	DS110 80M6B	
9.0	338	1.5	100	10320		
7.8	425	1.8	180	10320	DS110 / PC080 80M4A	
5.8	513	1.3	240	10320		
4.7	597	1.0	300	10320		
7.5	462	2.6	120	10320	DS110 / PC080 80M6B	
6.0	552	2.0	150	10320		
5.0	620	1.6	180	10320		
3.8	756	1.1	240	10320		



GÜÇ DEVİR TABLOLARI

GEARED PERFORMANCE TABLES

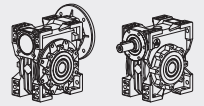

Motor Gücü Motor Power P_1 (kW)	Çıkış Devri Output Speed n_2 (min^{-1})	Çıkış Momenti Output Torque M_2 (Nm)	Servis Faktörü Service Factor f_B	Tahvil Oranı Ratio i_{ges}	Radyal Yük Radial Force F_R (N)	Tip Type		
0.55	4.7	639	2.0	300	10320	DS110 / 050 80M4A		
	3.5	826	1.4	400	10320			
	2.8	984	1.1	500	10320			
	2.3	1181	1.0	600	10320			
	1.9	1411	0.9	750	10320			
	0.55	3.8	756	1.6	240	13500	DS130 / PC080 80M6B	
		3.0	858	1.3	300	13500		
		2.8	996	1.6	500	13500	DS130 / 063 80M4A	
		1.9	1471	1.2	750	13500		
	0.55	1.2	2132	0.8	1200	13500	DS150 / 63 80M4A	
		0.8	2638	0.8	1800	18000		
	0.55	0.6	3182	0.8	2400	18000	DS150 / 63 80M4A	
0.75	560.0	12	3.9	5	1251	DS050 80M2A		
	373.3	17	3.0	7.5	1433			
	280.0	21	2.4	10	1577			
	186.7	33	1.7	15	1805			
	140.0	42	1.3	20	1987			
	112.0	51	1.0	25	2140			
	93.3	58	1.1	30	2274			
	280.0	23	2.7	5	1577		DS050 80H4B	
	186.7	34	2.1	7.5	1805			
	140.0	44	1.6	10	1987			
	93.3	63	1.2	15	2274			
	70.0	81	0.9	20	2503			
	0.75	140.0	43	2.3	20	2597	DS063 80M2A	
		112.0	52	1.8	25	2797		
		93.3	60	2.0	30	2973		
		70.0	77	1.4	40	3272		
		56.0	91	1.1	50	3524		
		46.7	104	0.9	60	3745		
		93.3	64	2.2	15	2973		DS063 80H4B
		70.0	83	1.6	20	3272		
	56.0	100	1.3	25	3524			
	46.7	114	1.4	30	3745			
	35.0	143	1.0	40	4122			
	0.75	120.0	52	2.9	7.5	2734	DS063 90S6A	
		90.0	68	2.3	10	3009		
		60.0	97	1.6	15	3444		
		45.0	123	1.2	20	3791		
		36.0	149	0.9	25	4084		
		30.0	167	1.0	30	4339		
		46.7	109	1.3	60	4421		DS075 80M2A
		28.0	156	0.8	100	5241		
	0.75	56.0	102	2.0	25	4160	DS075 80H4B	
		46.7	117	2.0	30	4421		
		35.0	147	1.5	40	4865		
		28.0	177	1.2	50	5241		
		23.3	200	1.0	60	5569		
	0.75	60.0	98	2.4	15	4065	DS075 90S6A	
		45.0	126	1.9	20	4474		
		35.0	153	1.4	25	4820		
		28.0	174	1.5	30	5122		
		23.3	216	1.1	40	5637		
	0.75	18.7	280	0.9	75	6000	DS075 / PC080 - 80H4B	
		15.6	313	1.0	90	6375		

GÜÇ DEVİR TABLOLARI

GEARED PERFORMANCE TABLES

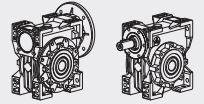

Motor Gücü Motor Power P_1 (kW)	Çıkış Devri Output Speed n_2 (min^{-1})	Çıkış Momenti Output Torque M_2 (Nm)	Servis Faktörü Service Factor f_B	Tahvil Oranı Ratio i_{ges}	Radyal Yük Radial Force F_R (N)	Tip Type
0.75	35.0	141	1.6	80	5383	DS090 80M2A
	28.0	166	1.2	100	5799	
	28.0	184	1.8	50	5799	DS090 80H4B
	23.3	212	1.5	60	6163	
	17.5	258	1.1	80	6783	
	14.0	302	0.9	100	7306	
	30.0	179	2.6	30	5667	
	22.5	226	1.8	40	6238	
	18.0	271	1.4	50	6719	
	15.0	306	1.1	60	7140	
	15.6	327	1.7	90	7054	DS090 / PC080 80H4B
	11.7	405	1.2	120	7764	
	9.3	483	0.9	150	8180	
	7.8	543	0.7	180	8180	
	17.5	274	1.9	80	8571	DS110 80H4B
	14.0	322	1.5	100	9232	
	15.0	325	2.1	60	9023	DS110 90S6A
	11.3	401	1.4	80	9931	
	9.0	462	1.1	100	10320	
	11.7	430	2.2	120	9811	DS110 / PC080 80H4B
	9.3	506	1.7	150	10320	
	7.8	580	1.3	180	10320	
	5.8	700	0.9	240	10320	
	12.4	393	3.2	73	9614	DS110 / PC090 90S6A
	9.3	508	2.3	96.8	10320	
	7.4	607	1.8	121	10320	
	6.2	682	1.5	145.2	10320	
	4.6	832	1.0	193.6	10320	
	9.3	446	2.8	300	10320	DS110 / 050 80M2A
	7.0	563	2.1	400	10320	
5.6	687	1.6	500	10320		
4.7	871	1.5	300	10320	DS110 / 050 80H4B	
3.5	1126	1.1	400	10320		
11.3	407	2.1	80	12989	DS130 90S6A	
9.0	470	1.7	100	13500		
5.8	712	1.4	240	13500	DS130 / PC080 80H4B	
4.7	813	1.1	300	13500		
12.4	393	4.4	73	12575	DS130 / PC090 90S6A	
9.3	508	3.2	96.8	13500		
7.4	607	2.6	121	13500		
6.2	682	2.1	145.2	13500		
4.6	832	1.5	193.6	13500		
3.7	944	1.2	242	13500		
2.8	1358	1.1	500	13500	DS063 / 130 80H4B	
2.3	1631	1.0	600	13500		
1.9	2005	0.9	750	13500		
1.6	2283	0.8	900	13500		
2.8	1291	1.8	500	18000	DS063 / 150 80H4B	
2.3	1529	1.7	600	18000		
1.9	1783	1.3	750	18000		
1.6	2215	0.9	900	18000		
1.2	2680	1.0	1200	18000		



GÜÇ DEVİR TABLOLARI

GEARED PERFORMANCE TABLES

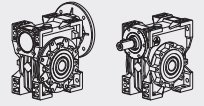

Motor Gücü Motor Power P_1 (kW)	Çıkış Devri Output Speed n_2 (min^{-1})	Çıkış Momenti Output Torque M_2 (Nm)	Servis Faktörü Service Factor f_B	Tahvil Oranı Ratio i_{ges}	Radyal Yük Radial Force F_R (N)	Tip Type
1.10	560.0	17	2.6	5	1251	DS050 80M2B
	373.3	25	2.1	7.5	1433	
	280.0	33	1.6	10	1577	
	186.7	48	1.2	15	1805	
	140.0	62	0.9	20	1987	
	186.7	48	2.1	15	2359	DS063 80M2B
	140.0	63	1.6	20	2597	
	112.0	77	1.2	25	2797	
	93.3	88	1.4	30	2973	
	70.0	113	1.0	40	3272	
	120.0	76	2.0	7.5	2734	DS063 90L6B
	90.0	99	1.5	10	3009	
	60.0	142	1.1	15	3444	
	45.0	180	0.8	20	3791	
	186.7	50	2.6	7.5	2359	DS063 90S4A
	140.0	65	2.0	10	2597	
	93.3	93	1.5	15	2973	
	70.0	122	1.1	20	3272	
	56.0	146	0.9	25	3524	
	46.7	167	1.0	30	3745	
	112.0	78	1.9	25	3302	
	93.3	90	1.9	30	3509	DS075 80M2B
	70.0	116	1.4	40	3862	
	56.0	139	1.1	50	4160	
	46.7	160	0.9	60	4421	
	90.0	100	2.3	10	3551	DS075 90L6B
	60.0	144	1.6	15	4065	
	45.0	184	1.3	20	4474	
	36.0	225	1.0	25	4820	
	30.0	256	1.0	30	5122	
	93.3	96	2.1	15	3509	DS075 90S4A
	70.0	123	1.7	20	3862	
	56.0	150	1.3	25	4160	
	46.7	171	1.3	30	4421	
	35.0	216	1.0	40	4865	
	35.0	207	1.1	80	5383	DS90 80M2B
	28.0	244	0.8	100	5799	
	36.0	231	1.6	25	5333	DS090 90L6B
	30.0	263	1.8	30	5667	
	22.5	331	1.2	40	6238	
	18.0	397	1.0	50	6719	
	15.0	448	0.8	60	7140	
35.0	225	1.6	40	5383	DS090 90S4A	
28.0	270	1.3	50	5799		
23.3	311	1.0	60	6163		
22.5	345	2.3	40	7882	DS110 90L6B	
18.0	414	1.8	50	8491		
15.0	476	1.4	60	9023		
11.3	588	1.0	80	9931		
28.0	281	2.3	50	9614	DS110 90S4A	
23.3	324	1.9	60	10320		
17.5	402	1.3	80	10320		
14.0	473	1.0	100	10320		
12.4	576	2.2	73	9614	DS110 / PC090 90L6B	
9.3	746	1.6	96.8	10320		
7.4	890	1.2	121	10320		
6.2	1000	1.0	145.2	10320		

GÜÇ DEVİR TABLOLARI

GEARED PERFORMANCE TABLES

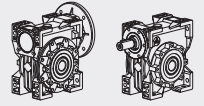

Motor Gücü Motor Power P_1 (kW)	Çıkış Devri Output Speed n_2 (min^{-1})	Çıkış Momenti Output Torque M_2 (Nm)	Servis Faktörü Service Factor f_B	Tahvil Oranı Ratio i_{ges}	Radyal Yük Radial Force F_R (N)	Tip Type
1.10	19.3	392	2.5	73	8298	DS110 / PC090 90S4A
	14.5	508	1.8	96.8	9133	
	11.6	599	1.5	121	9838	
	9.6	686	1.1	145.2	10320	
	7.2	828	0.8	193.6	10320	
	9.3	654	1.9	300	10320	DS110 / 050 80M2B
	7.0	845	1.4	400	10320	
	5.6	1007	1.1	500	10320	
	11.3	598	1.4	80	12989	DS130 90L6B
	9.0	689	1.1	100	13500	
	17.5	408	2.1	80	11210	DS130 - 90S4A
	14.0	480	1.5	100	12076	
	12.4	585	3.0	73	12575	DS130 / PC090 - 90L6B
	9.3	746	2.2	96.8	13500	
	7.4	890	1.7	121	13500	
	6.2	1000	1.4	145.2	13500	
	4.6	1220	1.0	193.6	13500	
	19.3	398	3.5	73	10853	DS130 / PC090 90S4A
	14.5	508	2.6	96.8	11945	
	11.6	608	2.0	121	12868	
	9.6	686	1.6	145.2	13500	
	7.2	843	1.2	193.6	13500	
	5.8	962	0.9	242	13500	
	4.7	1312	1.3	300	13500	DS130 / 063 90S4A
3.5	1671	1.0	400	13500		
2.8	1991	0.8	500	13500		
9.3	753	3.1	150	18000	DS150 / 063 90S4A	
7.0	966	2.4	200	18000		
5.6	1175	1.7	250	18000		
4.7	1364	1.7	300	18000		
3.5	1619	1.6	400	18000		
2.8	1893	1.2	500	18000		
2.3	2242	1.2	600	18000		
1.9	2616	0.9	750	18000		
1.50	186.7	68	1.9	7.5	2359	DS063 90H4B
	140.0	89	1.5	10	2597	
	93.3	127	1.1	15	2973	
	70.0	166	0.8	20	3272	
	373.3	35	2.7	7.5	1873	DS063 90S2A
	280.0	46	2.1	10	2061	
	186.7	66	1.6	15	2359	
	140.0	86	1.2	20	2597	
	112.0	105	0.9	25	2797	
	93.3	120	1.0	30	2973	
	120.0	105	2.0	7.5	3227	DS075 100L6A
	90.0	137	1.7	10	3551	
	60.0	196	1.2	15	4065	



GÜÇ DEVİR TABLOLARI

GEARED PERFORMANCE TABLES

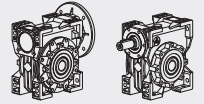

Motor Gücü Motor Power P_1 (kW)	Çıkış Devri Output Speed n_2 (min^{-1})	Çıkış Momenti Output Torque M_2 (Nm)	Servis Faktörü Service Factor f_B	Tahvil Oranı Ratio i_{ges}	Radyal Yük Radial Force F_R (N)	Tip Type	
1.50	140.0	90	2.2	10	3065	DS075 90H4B	
	93.3	130	1.5	15	3509		
	70.0	168	1.3	20	3862		
	56.0	205	1.0	25	4160		
	46.7	233	1.0	30	4421		
	280.0	46	46	3.1	10	2433	DS075 90S2A
	186.7	67	67	2.2	15	2785	
	140.0	87	87	1.8	20	3065	
	112.0	106	106	1.4	25	3302	
	93.3	123	123	1.4	30	3509	
	70.0	158	158	1.0	40	3862	
	56.0	189	189	0.8	50	4160	
	46.7	218	218	0.7	60	4421	
	90.0	138	138	2.7	10	3929	DS090 - 100L6A
	60.0	201	201	2.1	15	4498	
	45.0	258	258	1.5	20	4951	
	36.0	314	314	1.2	25	5333	
	30.0	358	358	1.0	30	5667	
	70.0	172	172	2.1	20	4273	DS090 - 90H4B
	56.0	210	210	1.6	25	4603	
	46.7	239	239	1.7	30	4891	
	35.0	307	307	1.2	40	5383	
	28.0	368	368	0.9	50	5799	
	23.3	424	424	0.8	60	6163	
	56.0	194	194	1.4	50	4603	DS090 90S2A
	46.7	227	227	1.1	60	4891	
	45.0	264	264	2.7	20	6256	DS110 100L6A
	36.0	322	322	2.4	25	6739	
	30.0	363	363	2.3	30	7161	
	22.5	471	471	1.7	40	7882	
18.0	565	565	1.3	50	8491		
15.0	649	649	1.1	60	9023		
35.0	319	319	2.2	40	6803	DS110 90H4B	
28.0	384	384	1.7	50	7328		
23.3	442	442	1.4	60	7787		
17.5	548	548	0.9	80	8571		
46.7	236	236	2.0	60	6181	DS110 90S2A	
35.0	299	299	1.3	80	6803		
28.0	353	353	1.0	100	7328		
19.3	535	535	1.9	73	8296		
14.5	693	693	1.3	96.8	9133		
11.6	817	817	1.1	121	9838		
9.6	936	936	0.8	145.2	10320		
22.5	478	478	2.3	40	10309	DS130 100L6A	
18.0	573	573	1.8	50	11105		
15.0	659	659	1.4	60	11801		
11.3	815	815	1.1	80	12989		
17.5	557	557	1.5	80	11210	DS130 90H4B	
14.0	655	655	1.1	100	12076		
19.3	542	542	2.6	73	10853	DS130 / PC090 - 90H4B	
14.5	693	693	1.9	96.8	11945		
11.6	830	830	1.5	121	12868		
9.6	936	936	1.1	145.2	13500		
7.2	1149	1149	0.8	194	13500		



GÜÇ DEVİR TABLOLARI

GEARED PERFORMANCE TABLES

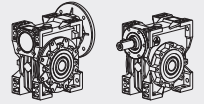

Motor Gücü Motor Power P_1 (kW)	Çıkış Devri Output Speed n_2 (min^{-1})	Çıkış Momenti Output Torque M_2 (Nm)	Servis Faktörü Service Factor f_B	Tahvil Oranı Ratio i_{ges}	Radyal Yük Radial Force F_R (N)	Tip Type		
1.50	9.3	915	1.9	300	13500	DS130 / 063 90S2A		
	7.0	1166	1.4	400	13500			
	5.6	1389	1.1	500	13500			
	1.50	4.7	1789	1.0	300	13500	DS130 / 063 90H4B	
		3.5	2279	0.7	400	13500		
		1.50	9.3	1026	2.3	150	18000	DS150 / 063 90H4B
			7.0	1317	1.8	200	18000	
			5.6	1602	1.3	250	18000	
			4.7	1860	1.3	300	18000	
			3.5	2208	1.2	400	18000	
			2.8	2582	0.9	500	18000	
			2.3	3057	0.9	600	18000	
		2.20	373.3	51	1.8	7.5	1873	DS063 90L2A
			280.0	67	1.5	10	2061	
186.7			97	1.1	15	2359		
2.20			186.7	100	1.8	7.5	2785	DS075 100L4A
			140.0	132	1.5	10	3065	
	93.3		191	1.0	15	3509		
2.20	373.3		51	2.5	7.5	2210	DS075 90L2A	
	280.0		68	2.1	10	2433		
	186.7		98	1.5	15	2785		
	140.0		128	1.3	20	3065		
	112.0		156	1.0	25	3302		
	93.3		180	0.9	30	3509		
2.20	186.7		101	2.9	7.5	3081	DS090 100L4A	
	140.0		134	2.3	10	3391		
	93.3		194	1.9	15	3882		
	70.0		252	1.4	20	4273		
	56.0		308	1.1	25	4603		
	46.7		351	1.2	30	4891		
2.20	120.0		156	2.2	7.5	3570	DS090 112M6A	
	90.0		203	1.8	10	3929		
	60.0		294	1.4	15	4498		
	45.0		378	1.0	20	4951		
2.20	140.0		131	2.0	20	3391	DS090 90L2A	
	112.0		159	1.6	25	3653		
	93.3		185	1.7	30	3882		
	70.0		237	1.2	40	4273		
	56.0		285	0.9	50	4603		
2.20	70.0		255	2.5	20	5399	DS110 100L4A	
	56.0		315	2.2	25	5816		
	46.7		356	2.0	30	6181		
	35.0	468	1.5	40	6803			
	28.0	563	1.2	50	7328			
	23.3	648	1.0	60	7787			
2.20	90.0	205	3.5	25	4965	DS110 112M6A		
	60.0	298	2.6	30	5684			
	45.0	388	1.9	40	6256			
	36.0	473	1.6	50	6739			
	30.0	532	1.6	60	7161			
2.20	112.0	163	3.1	25	4616	DS110 90L2A		
	93.3	187	3.0	30	4905			
	70.0	246	2.1	40	5399			
	56.0	296	1.7	50	5816			
	46.7	347	1.4	60	6181			



GÜÇ DEVİR TABLOLARI

GEARED PERFORMANCE TABLES

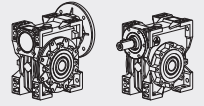

Motor Gücü Motor Power P_1 (kW)	Çıkış Devri Output Speed n_2 (min^{-1})	Çıkış Momenti Output Torque M_2 (Nm)	Servis Faktörü Service Factor f_B	Tahvil Oranı Ratio i_{ges}	Radyal Yük Radial Force F_R (N)	Tip Type	
2.20	38.6	398	2.1	73	6586	DS110 / PC090 90L2A	
	28.9	516	1.5	96.8	7249		
	23.1	617	1.2	121	7809		
	DS130 100L4A	35.0	468	2.2	40	8897	
		28.0	563	1.7	50	9584	
		23.3	648	1.4	60	10185	
		17.5	816	1.0	80	11210	
		DS130 112M6A	36.0	479	2.2	25	8897
			30.0	546	2.1	30	9366
	22.5		700	1.6	40	10309	
	18.0		840	1.2	50	11105	
	15.0		966	1.0	60	11801	
	DS130 90L2A	35.0	438	1.3	80	8897	
		28.0	525	1.0	100	9584	
	DS130 / PC090 90L2A	38.6	409	2.9	73	8614	
		28.9	545	1.9	96.8	9481	
		23.1	654	1.4	121	10213	
		19.3	752	1.3	145.2	10853	
DS150 100L4A	28.0	570	2.5	50	13103		
	23.3	657	1.9	60	13924		
	17.5	816	1.4	80	15325		
	14.0	960	1.0	100	16508		
	3.00	373.3	70	1.9	7.5	2210	DS075 100L2A
		280.0	92	1.6	10	2433	
DS075 100L4B		186.7	137	1.4	7.5	2785	
		140.0	180	1.1	10	3065	
		93.3	261	0.8	15	3509	
DS090 100L2A		373.3	71	3.0	7.5	2446	
		280.0	92	2.6	10	2692	
DS090 100L4B		186.7	138	2.1	7.5	3081	
		140.0	182	1.7	10	3391	
		93.3	264	1.4	15	3882	
		70.0	344	1.0	20	4273	
		56.0	420	0.8	25	4603	
		46.7	479	0.9	30	4891	
DS110 100L4B		93.3	264	2.5	15	3081	
		70.0	348	1.9	20	3391	
		56.0	430	1.6	25	3882	
		46.7	485	1.5	30	4273	
		35.0	638	1.1	40	4603	
DS110 132S6A	28.0	767	0.9	50	4891		
	120.0	212	3.1	7.5	4511		
	90.0	280	2.5	10	4965		
	60.0	406	1.9	15	5684		
DS130 100L4B	45.0	528	1.4	20	6256		
	56.0	430	2.2	25	7607		
	46.7	491	2.1	30	8084		
	35.0	638	1.6	40	8897		
	28.0	767	1.3	50	9584		
	23.3	884	1.0	60	10185		
DS130 132S6A	17.5	1113	0.8	80	11210		
	90.0	280	3.4	10	6494		
	60.0	406	2.6	15	7434		
	45.0	535	1.9	20	8182		
	36.0	653	1.6	25	8814		
	30.0	745	1.6	30	9366		
22.5	955	1.2	40	10309			

GÜÇ DEVİR TABLOLARI

GEARED PERFORMANCE TABLES

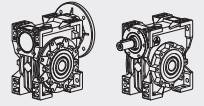

Motor Gücü Motor Power P_1 (kW)	Çıkış Devri Output Speed n_2 (min^{-1})	Çıkış Momenti Output Torque M_2 (Nm)	Servis Faktörü Service Factor f_B	Tahvil Oranı Ratio i_{ges}	Radyal Yük Radial Force F_R (N)	Tip Type
3.00	28.0	778	1.8	50	13103	DS150 100L4B
	23.3	896	1.4	60	13924	
	17.5	1113	1.0	80	15325	
	14.0	1310	1.4	100	16508	
4.00	373.3	93	1.4	7.5	2210	DS075 112M2A
	280.0	123	1.2	10	2433	DS075 112M4A
	186.7	182	1.0	7.5	2785	DS075 112M4A
	140.0	240	0.8	10	3065	
	373.3	94	2.2	7.5	2446	DS090 112M2A
	280.0	123	1.9	10	2692	
	186.7	184	1.6	7.5	3081	DS090 112M4A
	140.0	243	1.3	10	3391	
	93.3	352	1.0	15	3882	
	70.0	458	0.8	20	4273	
	140.0	243	2.5	10	4285	DS110 112M4A
	93.3	352	1.9	15	4905	
	70.0	464	1.4	20	5399	
	56.0	573	1.2	25	5816	
	46.7	647	1.1	30	6181	
	120.0	283	2.3	7.5	4511	DS110 132M6B
	90.0	374	1.9	10	4985	
	60.0	541	1.4	15	5684	
	56.0	573	1.6	25	7607	DS130 112M4A
	46.7	655	1.6	30	8064	
35.0	851	1.2	40	8897		
28.0	1023	1.0	50	9564		
23.3	1179	0.8	60	10185		
120.0	287	3.1	7.5	5901	DS130 132M6B	
90.0	374	2.6	10	6494		
60.0	541	2.0	15	7434		
45.0	713	1.5	20	8182		
36.0	870	1.2	25	8814		
28.0	1037	1.4	50	13103	DS150 112M4A	
23.3	1195	1.1	60	13924		
17.5	1484	0.8	80	15325		
5.50	186.7	253	2.2	7.5	3893	DS110 132S4A
	140.0	334	1.8	10	4285	
	93.3	484	1.4	15	4905	
	70.0	638	1.0	20	5399	
	140.0	334	2.5	10	5605	DS130 132S4A
	93.3	490	1.9	15	6416	
	70.0	645	1.4	20	7062	
	56.0	788	1.2	25	7607	
	46.7	900	1.2	30	8084	
	35.0	1171	0.9	40	8897	
	70.0	645	2.0	20	9654	DS150 132S4A
	56.0	788	1.5	25	10400	
	46.7	934	1.3	30	11051	
35.0	1171	1.3	40	12163		
28.0	1426	1.0	50	13103		
23.3	1643	0.8	60	13924		
7.50	186.7	345	1.6	7.5	3893	
	140.0	455	1.3	10	4285	
	93.3	660	1.0	15	4905	



GÜÇ DEVİR TABLOLARI

GEARED PERFORMANCE TABLES

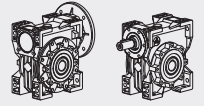

Motor Gücü Motor Power P_1 (kW)	Çıkış Devri Output Speed n_2 (min^{-1})	Çıkış Momenti Output Torque M_2 (Nm)	Servis Faktörü Service Factor f_B	Tahvil Oranı Ratio i_{ges}	Radyal Yük Radial Force F_R (N)	Tip Type
7.50	186.7	349	2.1	7.5	5092	DS130 132M4B
	140.0	455	1.8	10	5605	
	93.3	668	1.4	15	6416	
	70.0	880	1.0	20	7062	
	56.0	1074	0.9	25	7607	
	46.7	1228	0.8	30	8084	
	35.0	1596	0.7	40	8897	DS150 132M4B
	70.0	880	1.5	20	9654	
	56.0	1074	1.1	25	10400	
	46.7	1274	0.9	30	11051	
11.0	35.0	1596	1.0	40	12163	DS150 160M4A
	186.7	512	2.3	7.5	6962	
	140.0	675	1.8	10	7663	
	93.3	990	1.3	15	8771	
	70.0	1291	1.0	20	9654	
15.0	56.0	1576	0.8	25	10400	DS150 160L4B
	186.7	698	1.7	7.5	6962	
	140.0	921	1.3	10	7663	
	93.3	1351	0.9	15	8771	
	70.0	1760	0.7	20	9654	

ÖLÇÜ SAYFALARI DIMENSION PAGES

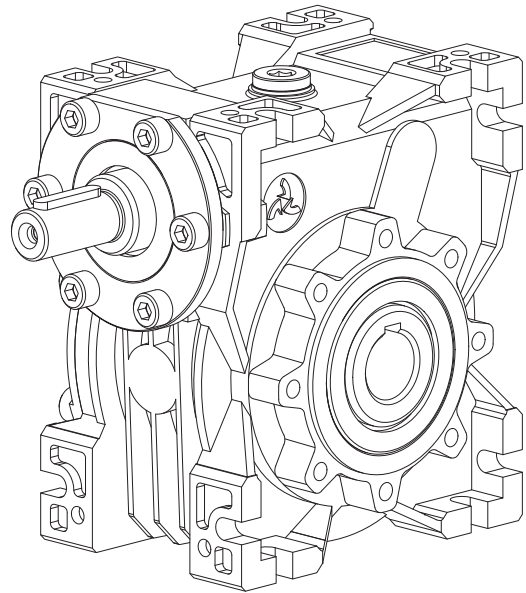
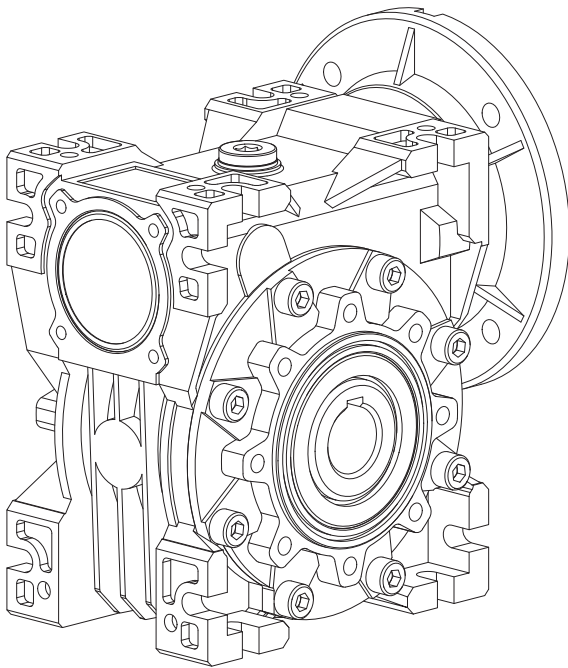

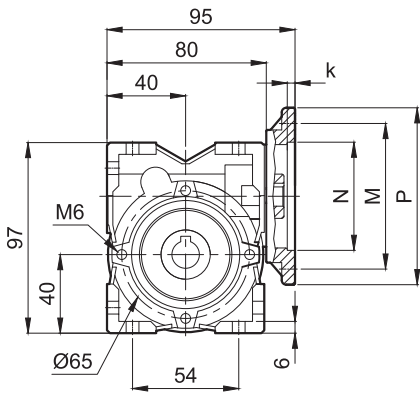
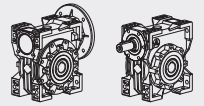

DS-VS

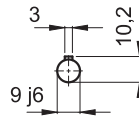
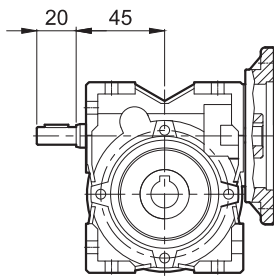
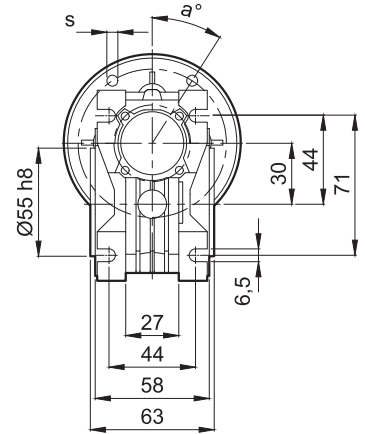
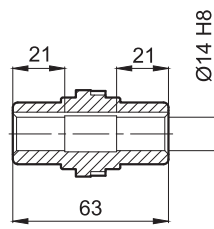
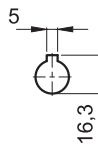
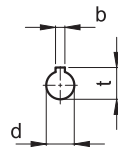

	P	M	N	k	d	b	t	s	a
56/B14	80	65	50	4	9	3	10,4	6	45°
56/B5	120	100	80	4	9	3	10,4	7	45°
63/B14	90	75	60	4	11	4	12,8	6	45°
63/B5	140	115	95	4	11	4	12,8	10	45°

DSV

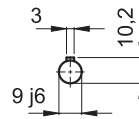
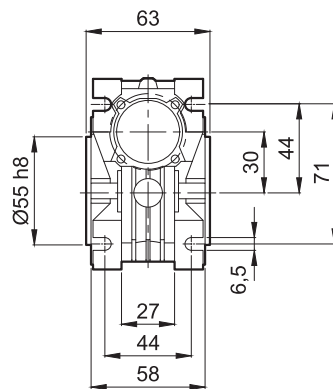
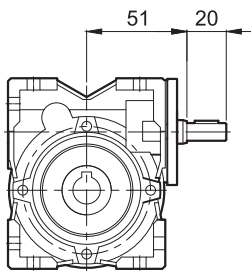

DSV-VS

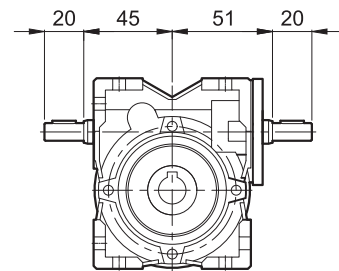

FA

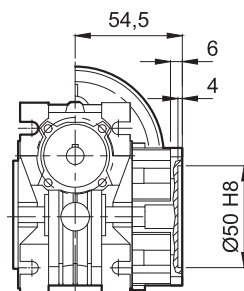
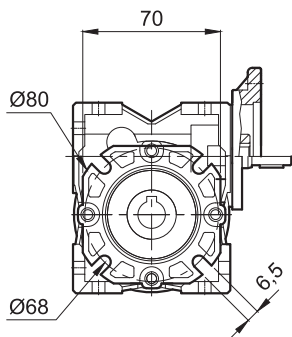

Motorsuz Ağırlık
Weight Without Motor

1,2 Kg



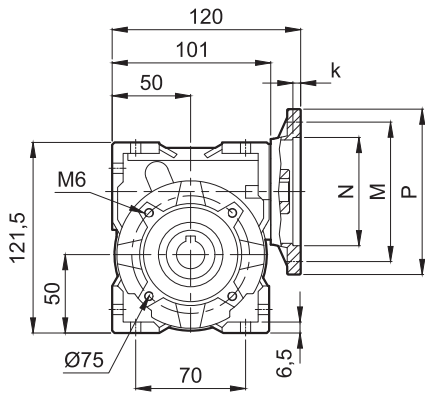
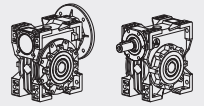

DS-VS

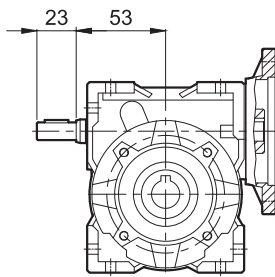
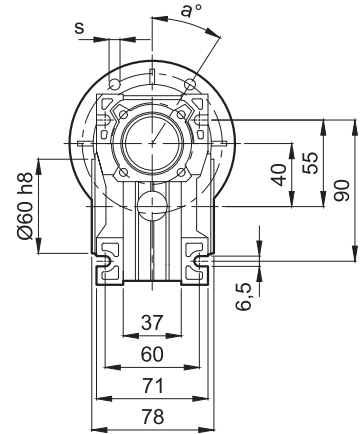
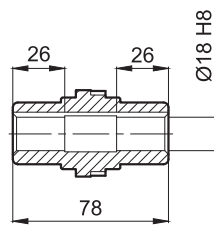
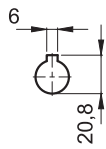
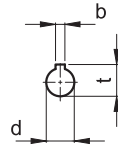

DSV

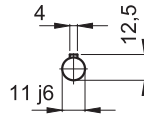

	P	M	N	k	d	b	t	s	a
63/B14	90	75	60	4	11	4	12,8	6	45°
63/B5	140	115	95	4	11	4	12,8	10	45°
71/B14	105	85	70	4	14	5	16,3	7	45°
71/B5	160	130	110	4	14	5	16,3	10	45°

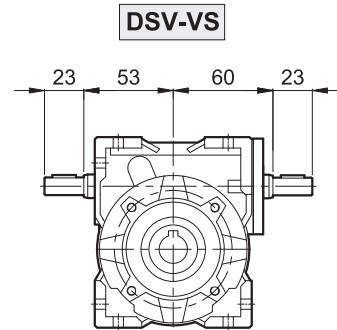
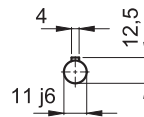
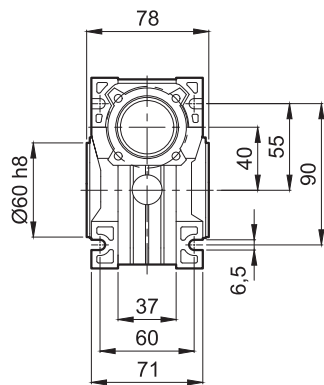
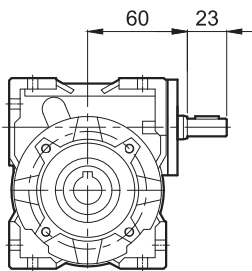

DSV-VS

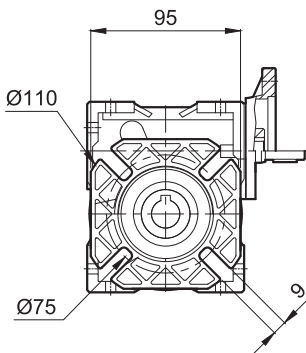

FA

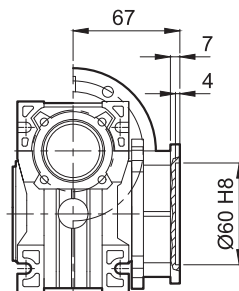

FB

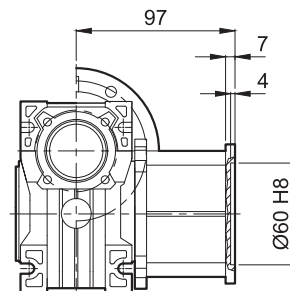

Motorsuz Ağırlık
Weight Without Motor

2,5 Kg 29



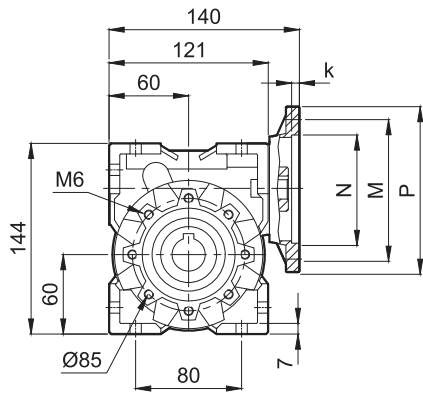
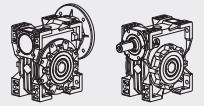

DS-VS

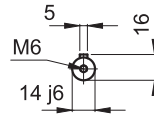
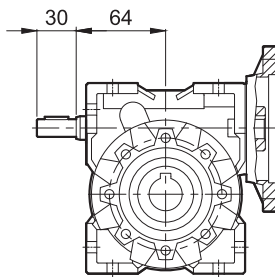
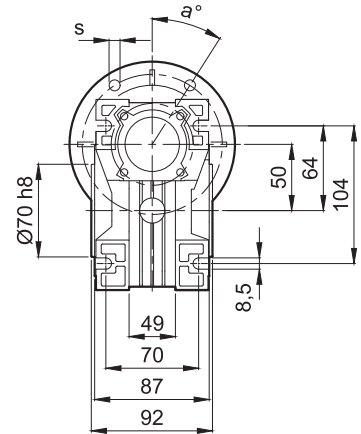
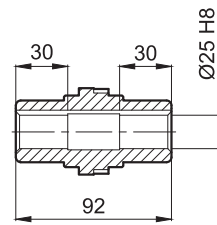
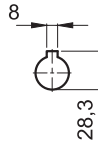
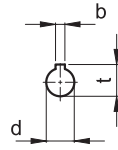

	P	M	N	k	d	b	t	s	a
71/B14	105	85	70	4	14	5	16,3	7	45°
71/B5	160	130	110	4	14	5	16,3	10	45°
80/B14	120	100	80	4	19	6	21,8	7	45°
80/B5	200	165	130	4	19	6	21,8	12	45°

DSV

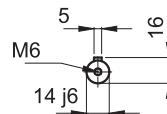
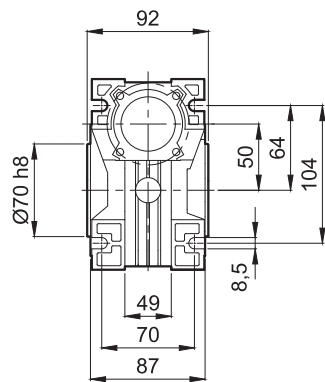
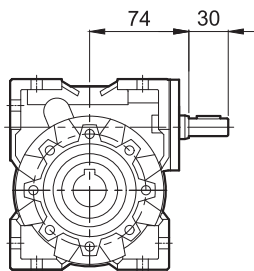

DSV-VS

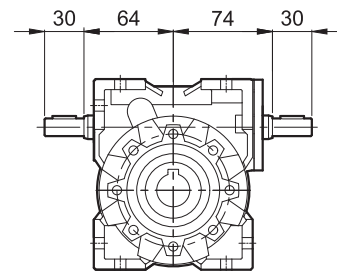

FA

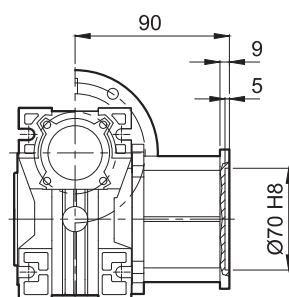
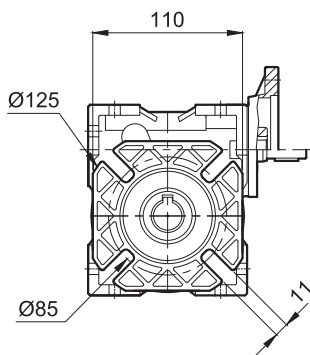

FB

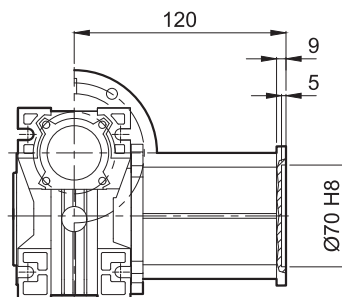

Motorsuz Ağırlık
Weight Without Motor

3,8 Kg



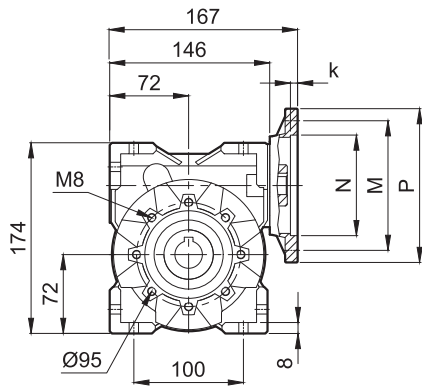
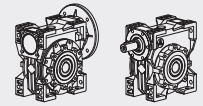

DS-VS

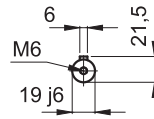
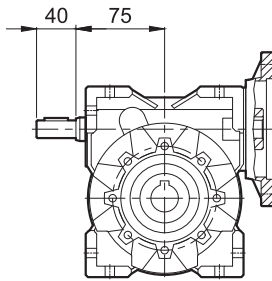
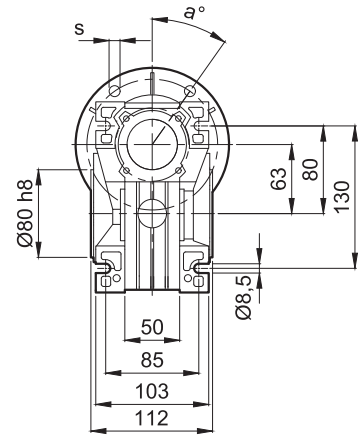
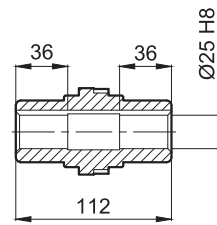
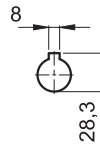
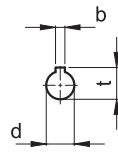

	P	M	N	k	d	b	t	s	a
80/B14	120	100	80	4	19	6	21,8	7	45°
80/B5	200	165	130	4	19	6	21,8	12	45°
90/B14	140	115	95	4	24	8	27,3	9	45°
90/B5	200	165	130	4	24	8	27,3	12	45°

DSV

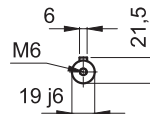
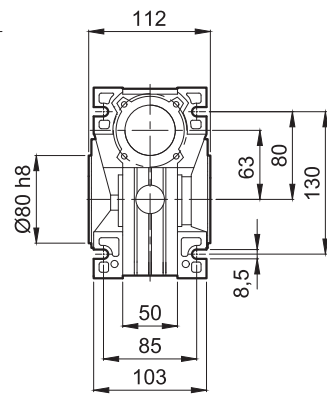
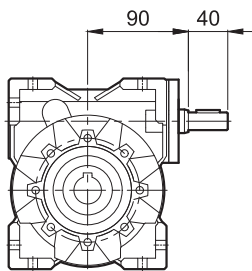

DSV-VS

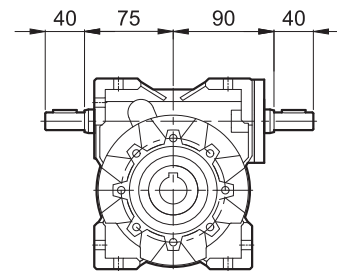

FA

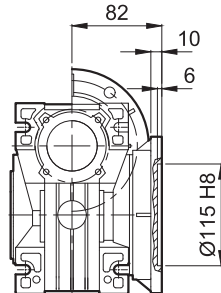
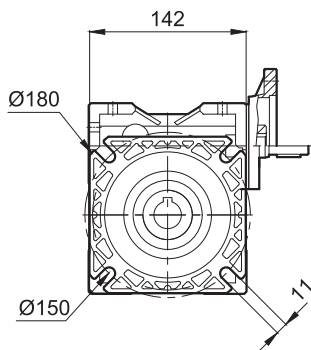

FB

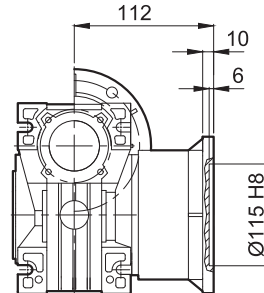

Motorsuz Ağırlık
Weight Without Motor

6,5 Kg



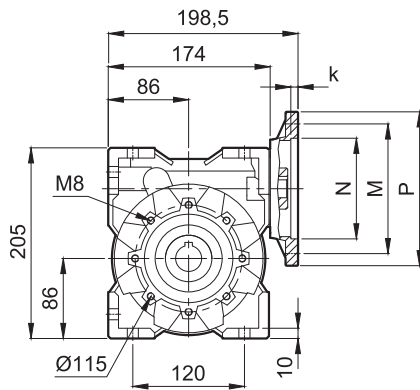
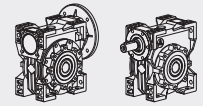

DS-VS

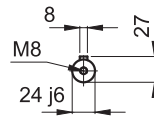
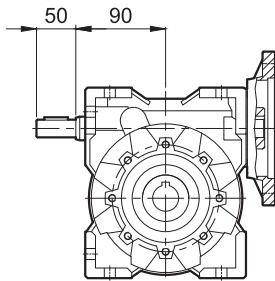
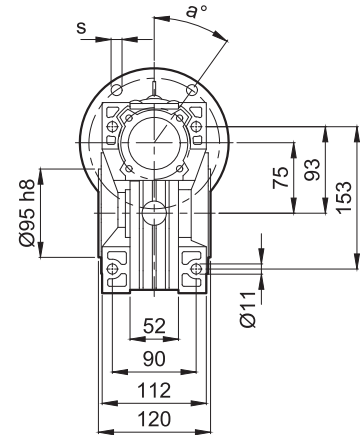
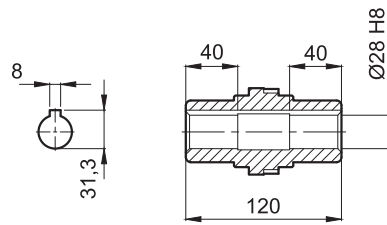
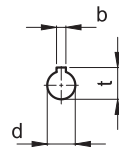

	P	M	N	k	d	b	t	s	a
80/B14	120	100	80	4	19	6	21,8	7	45°
80/B5	200	165	130	4	19	6	21,8	12	45°
90/B14	140	115	95	4	24	8	27,3	9	45°
90/B5	200	165	130	4	24	8	27,3	12	45°
100-112/B14	160	130	110	5	28	8	31,3	9	45°
100-112/B5	250	215	180	5	28	8	31,3	14,5	45°

DSV

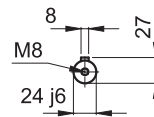
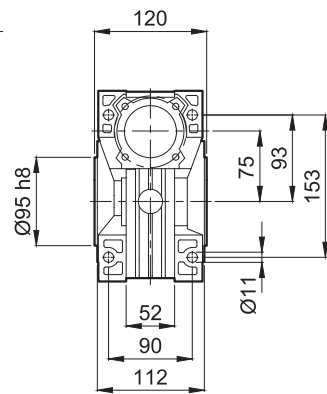
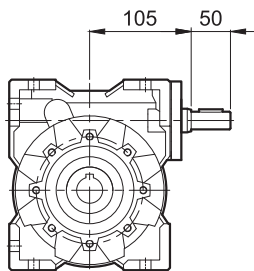

DSV-VS

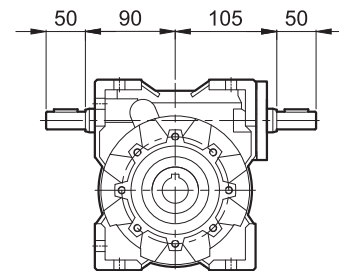

FA

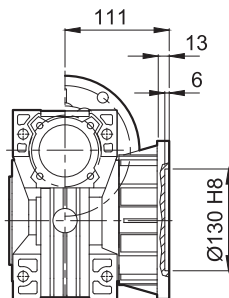

FB

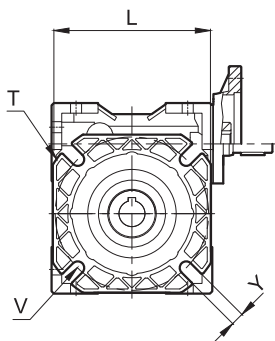
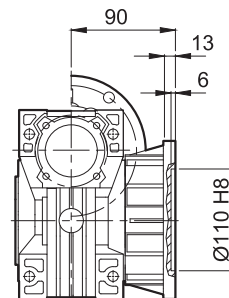

	FA	FB
T	200	160
V	165	130
Y	14	11
L	170	160

Motorsuz Ağırlık
Weight Without Motor

9 Kg



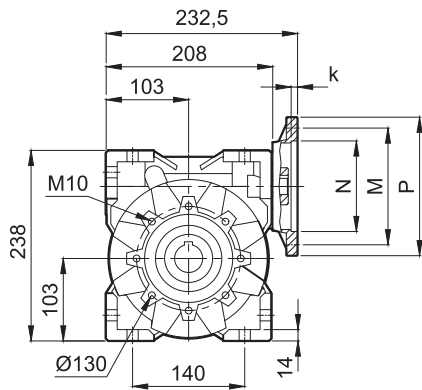
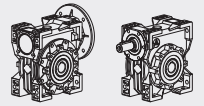

DS-VS

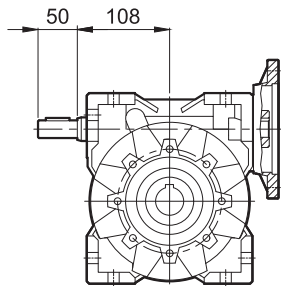
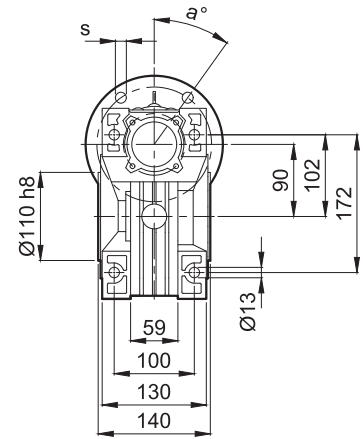
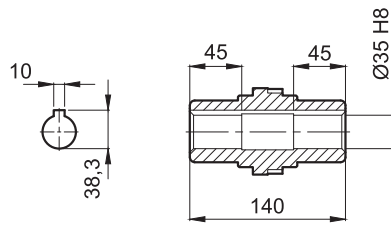
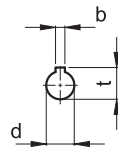

DSV

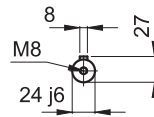

	P	M	N	k	d	b	t	s	a
80/B14	120	100	80	4	19	6	21,8	7	45°
80/B5	200	165	130	4	19	6	21,8	12	45°
90/B14	140	115	95	4	24	8	27,3	9	45°
90/B5	200	165	130	4	24	8	27,3	12	45°
100-112/B14	160	130	110	5	28	8	31,3	9	45°
100-112/B5	250	215	180	5	28	8	31,3	14,5	45°

DSV-VS

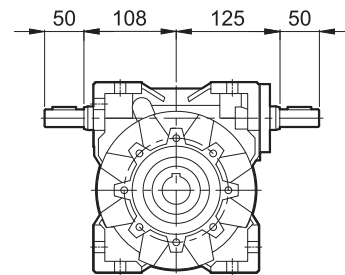
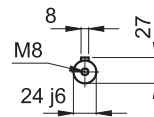
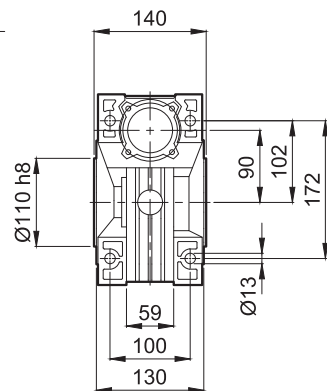
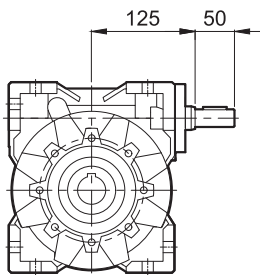

FA

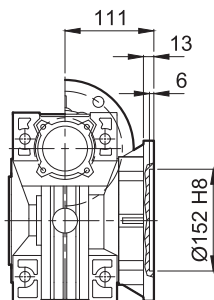
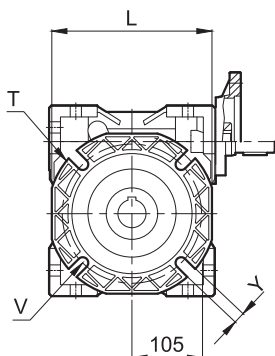

FB

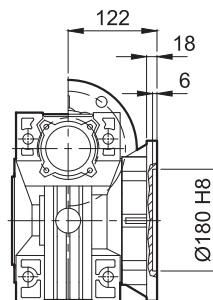

	FA	FB
T	210	250
V	175	215
Y	14	14
L	200	-

Motorsuz Ağırlık
Weight Without Motor

14 Kg



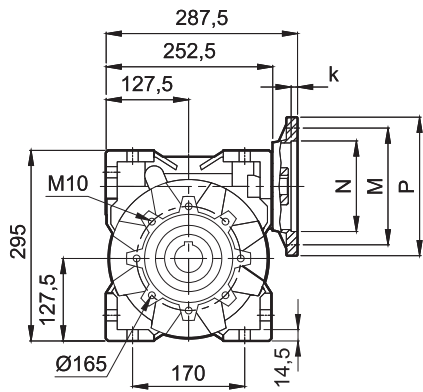
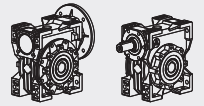

DS-VS

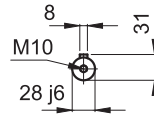
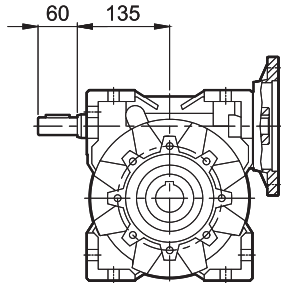
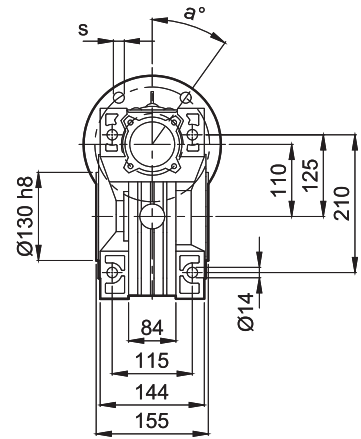
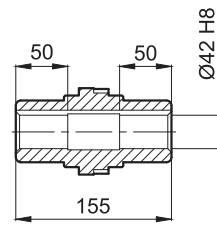
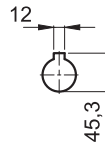
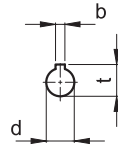

	P	M	N	k	d	b	t	s	a
80/B5	200	165	130	4	19	6	21,8	12	45°
90/B5	200	165	130	4	24	8	27,3	12	45°
100-112/B14	160	130	110	5	28	8	31,3	9	45°
100-112/B5	250	215	180	5	28	8	31,3	14,5	45°
132/B5	300	265	230	5	38	10	41,3	14,5	45°
132/B14	200	165	130	4	38	10	41,3	12	45°

DSV

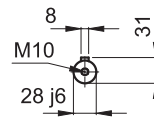
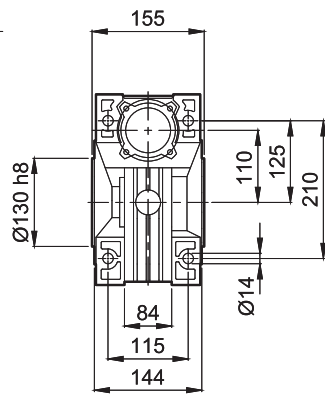
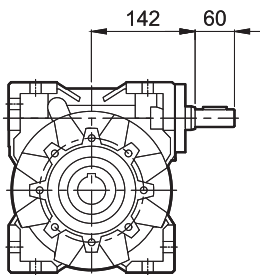

DSV-VS

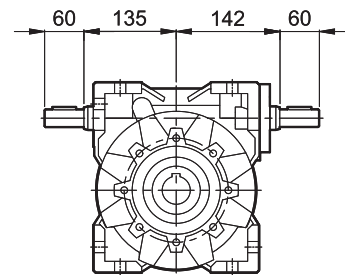

FA

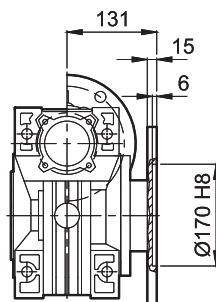
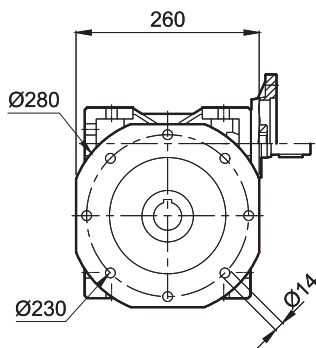

FB

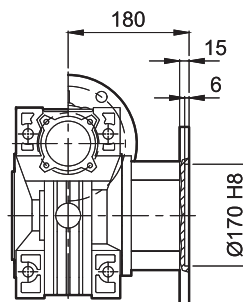

Motorsuz Ağırlık
Weight Without Motor

39 Kg



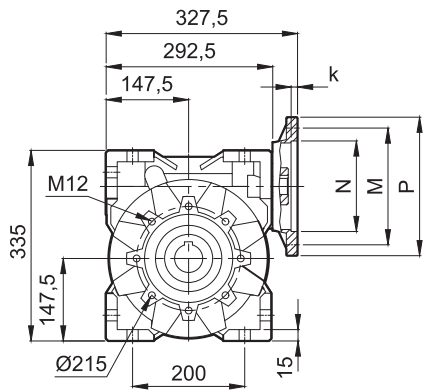
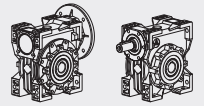

DS-VS

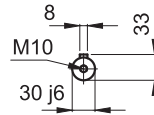
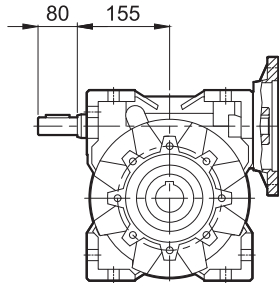
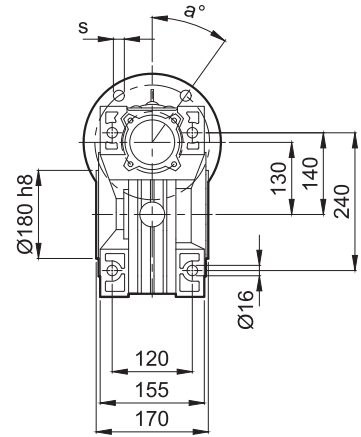
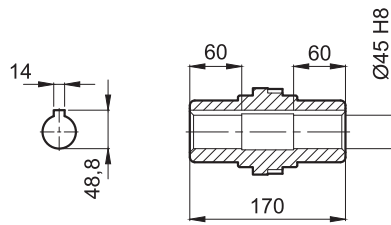
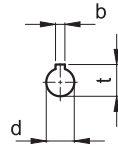

	P	M	N	k	d	b	t	s	a
90/B5	200	165	130	4	24	8	27,3	12	45°
100-112/B14	160	130	110	5	28	8	31,3	9	45°
100-112/B5	250	215	180	5	28	8	31,3	14,5	45°
132/B5	300	265	230	5	38	10	41,3	14,5	45°
132/B14	200	165	130	4	38	10	41,3	12	45°

DSV

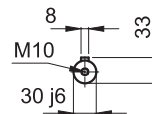
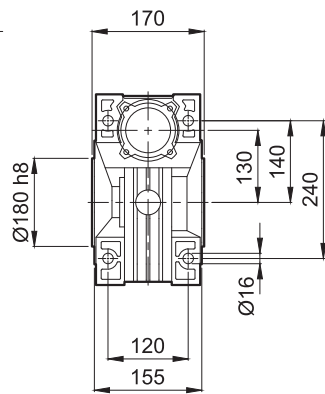
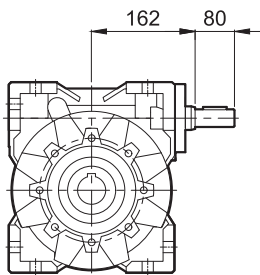

DSV-VS

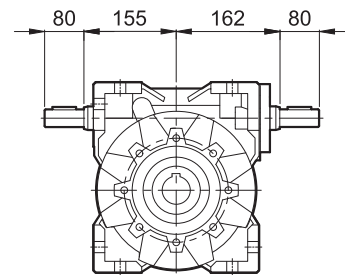

FA

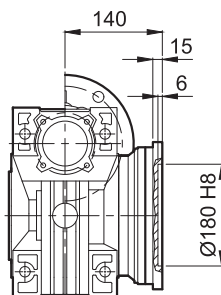
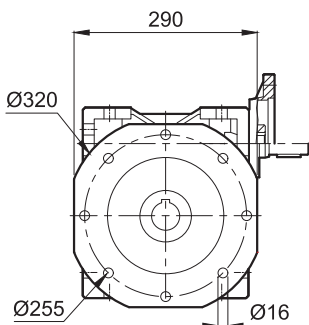

Motorsuz Ağırlık
Weight Without Motor

39 Kg



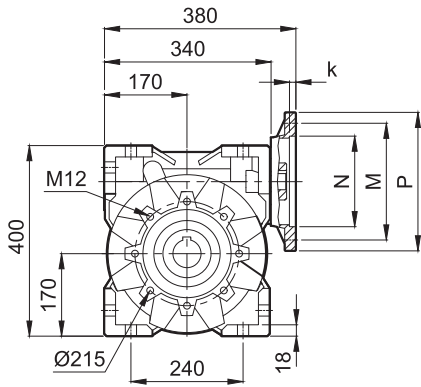
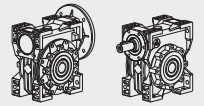

DS-VS

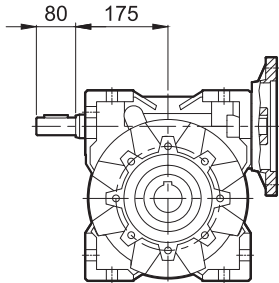
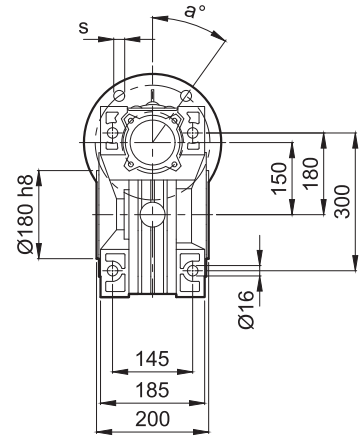
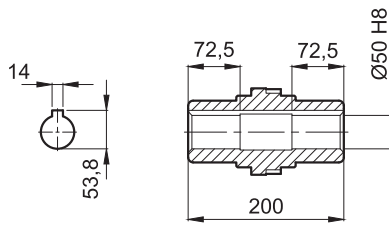
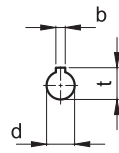

DSV

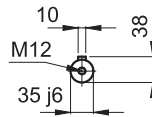

	P	M	N	k	d	b	t	s	a
100-112/B5	250	215	180	5	28	8	31,3	14,5	45°
132/B14	200	165	130	5	28	10	41,3	11	45°
132/B5	300	265	230	5	38	10	41,3	14,5	45°
160/B5	350	300	250	6	42	12	45,3	16,5	45°

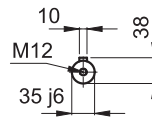
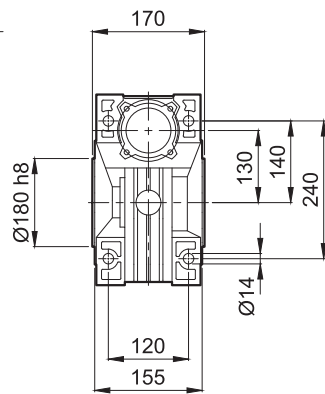
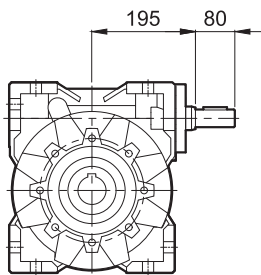

DSV-VS

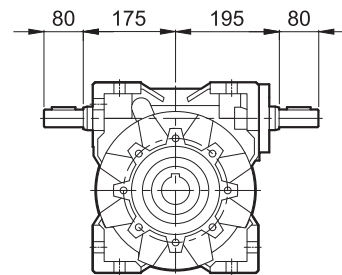

FA

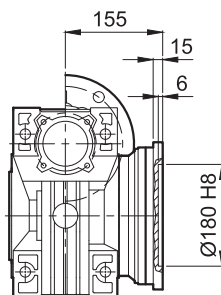
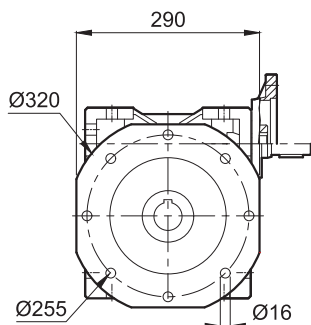

Motorsuz Ağırlık
Weight Without Motor

84 Kg



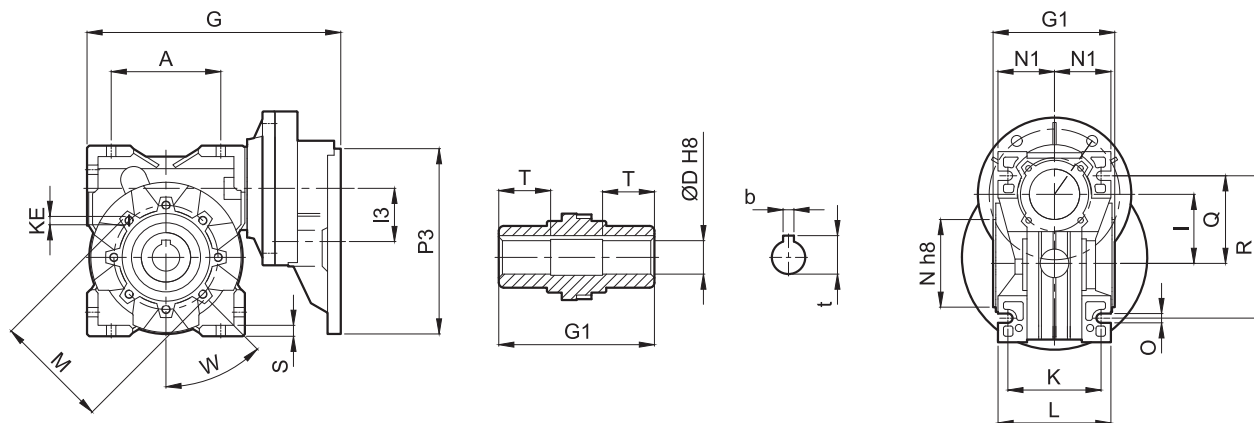
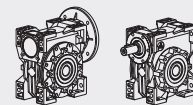

	A	G	G1	I	I3	KE	K	L	M	N	N1	O	P3	Q	R	S	W
DS040-PC063	70	165	78	40	40	M8	60	71	75	60	35,5	6,5	140	55	90	7	45
DS050-PC063	80	185	92	50	40	M8	70	85	85	70	47,5	8,5	140	64	104	8	45
DS063-PC063	100	212	112	63	40	M8	85	103	95	80	51,5	8,5	140	80	130	10	45
DS050-PC071	80	193	92	50	50	M8	70	85	85	70	47,5	8,5	160	64	104	8	45
DS063-PC071	100	220	112	63	50	M8	85	103	95	80	51,5	8,5	160	80	130	10	45
DS075-PC071	120	251,5	120	75	50	M8	90	112	115	95	56	11	160	93	153	11	45
DS090-PC071	140	285,5	140	90	50	M8	100	130	130	110	65	13	160	102	172	14	45
DS075-PC080	120	267,5	120	75	63	M8	90	112	115	95	56	11	200	93	153	11	45
DS090-PC080	140	301,5	140	90	63	M10	100	130	130	110	65	13	200	102	172	14	45
DS110-PC080	170	356,5	155	110	63	M10	115	144	165	130	72	14	200	125	210	16	45
DS130-PC080	200	396,5	170	130	63	M10	120	155	215	180	77,5	16	200	140	240	16	45
DS110-PC090	170	356,5	155	110	63	M10	115	144	165	130	72	14	200	125	210	16	45
DS130-PC090	200	396,5	170	130	63	M10	120	155	215	180	77,5	16	200	140	240	16	45

	D	b	t	T
040	18	6	20,8	26
	19	6	21,8	26
050	25	8	28,3	30
	24	8	27,3	30
063	25	8	28,3	36
	28	8	31,3	36
075	28	8	31,3	40
	30	8	33,3	40
	32	10	35,3	40
	35	10	38,3	40
090	35	10	38,3	45
	38	10	41,3	45
	40	12	43,3	45
110	42	12	45,3	50
130	45	14	48,8	60

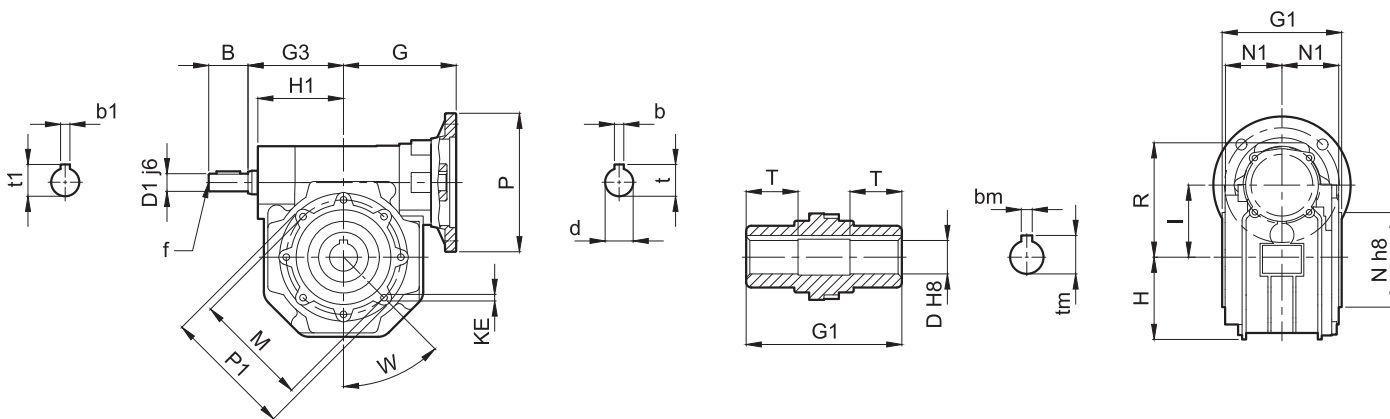
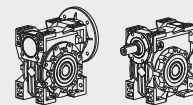

	B	D1	G	G1	G3	H	H1	I	KE	M	N	N1	P1	W	b1	t1	f1
DY030-VS	20	9	55	63	45	40	40	30	M6	65	55	29	75	0	3	10,2	-
DY040-VS	23	11	70	78	53	50	50	40	M6	75	60	36,5	87	45	4	12,5	-
DY050-VS	30	14	80	92	64	60	60	50	M8	85	70	43,5	100	45	5	16	M6
DY063-VS	40	19	95	112	75	72	72	63	M8	95	80	53	110	45	6	21,5	M6
DY075-VS	50	24	112,5	120	90	86	86	75	M8	115	95	57	140	45	8	27	M8
DY090-VS	50	24	129,5	140	108	103	103	90	M10	130	110	67	160	45	8	27	M8
DY110-VS	60	28	168	155	135	127,5	127,5	110	M10	144	130	74	200	45	8	31	M10
DY130-VS	80	30	180	170	155	147,5	147,5	130	M12	155	180	81	250	45	8	33	M10
DY150-VS	80	35	210	200	175	170	170	150	M12	185	180	96	250	45	10	38	M12

	D	b	t	T
DY030-VS	14	5	16,3	21
DY040-VS	18	6	20,8	26
	19	6	21,8	26
DY050-VS	25	8	28,3	30
	24	8	27,3	30
DY063-VS	25	8	28,3	36
	28	8	31,3	36
DY075-VS	28	8	31,3	40
	30	8	33,3	40
	32	10	35,3	40
	35	10	38,3	40
DY090-VS	35	10	38,3	45
	38	10	41,3	45
DY110-VS	40	12	43,3	45
	42	12	45,3	50
DY130-VS	45	14	48,8	60
DY150-VS	50	14	53,8	72,5

B5	P	d	b	t
056	120	9	3	10,4
063	140	11	4	12,8
071	160	14	5	16,3
080	200	19	6	21,8
090	200	24	8	27,3
100	250	28	8	31,3
112	250	28	8	31,3
132	300	38	10	41,3
160	350	42	12	45,3

B14	P	D1	b1	t1
056	80	9	3	10,4
063	90	11	4	12,8
071	105	14	5	16,3
080	120	19	6	21,8
090	140	24	8	27,3
100	160	28	8	31,3
112	160	28	8	31,3
132	200	38	10	41,3

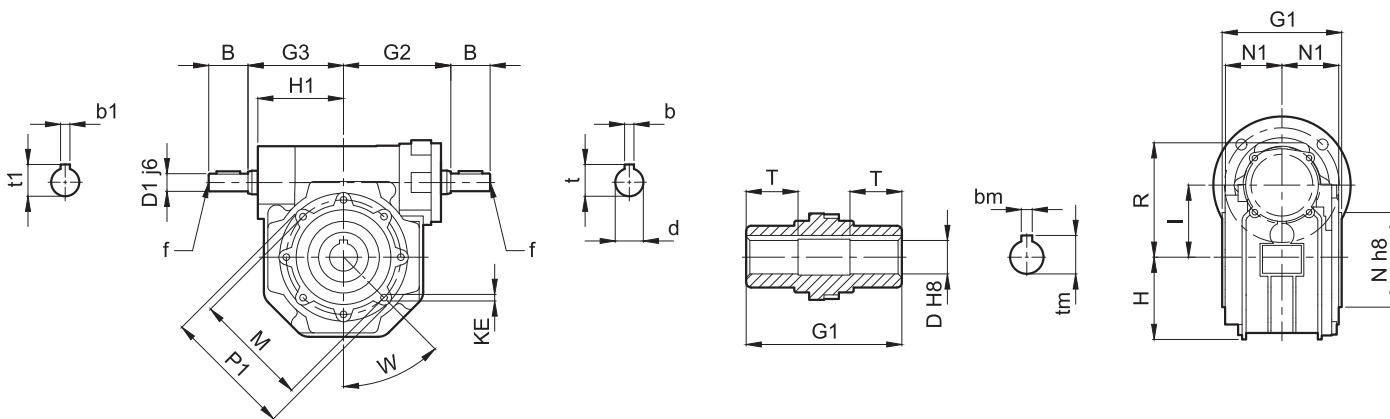
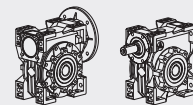

	B	D1	G1	G2	G3	H	H1	I	KE	M	N	N1	P1	W	b1	t1	f1
DYV030-VS	20	9	63	51	45	40	40	30	M6	65	55	29	75	0	3	10,2	-
DYV040-VS	23	11	78	60	53	50	50	40	M6	75	60	36,5	87	45	4	12,5	-
DYV050-VS	30	14	92	74	64	60	60	50	M8	85	70	43,5	100	45	5	16	M6
DYV063-VS	40	19	112	90	75	72	72	63	M8	95	80	53	110	45	6	21,5	M6
DYV075-VS	50	24	120	105	90	86	86	75	M8	115	95	57	140	45	8	27	M8
DYV090-VS	50	24	140	125	108	103	103	90	M10	130	110	67	160	45	8	27	M8
DYV110-VS	60	28	155	142	135	127,5	127,5	110	M10	144	130	74	200	45	8	31	M10
DYV130-VS	80	30	170	162	155	147,5	147,5	130	M12	155	180	81	250	45	8	33	M10
DYV150-VS	80	35	200	195	175	170	170	150	M12	185	180	96	250	45	10	38	M12

	D	bm	tm	T
DYV030-VS	14	5	16,3	21
DYV040-VS	18	6	20,8	26
	19	6	21,8	26
DYV050-VS	25	8	28,3	30
	24	8	27,3	30
DYV063-VS	25	8	28,3	36
	28	8	31,3	36
DYV075-VS	28	8	31,3	40
	30	8	33,3	40
	32	10	35,3	40
	35	10	38,3	40
DYV090-VS	35	10	38,3	45
	38	10	41,3	45
	40	12	43,3	45
DYV110-VS	42	12	45,3	50
DYV130-VS	45	14	48,8	60
DYV150-VS	50	14	53,8	72,5

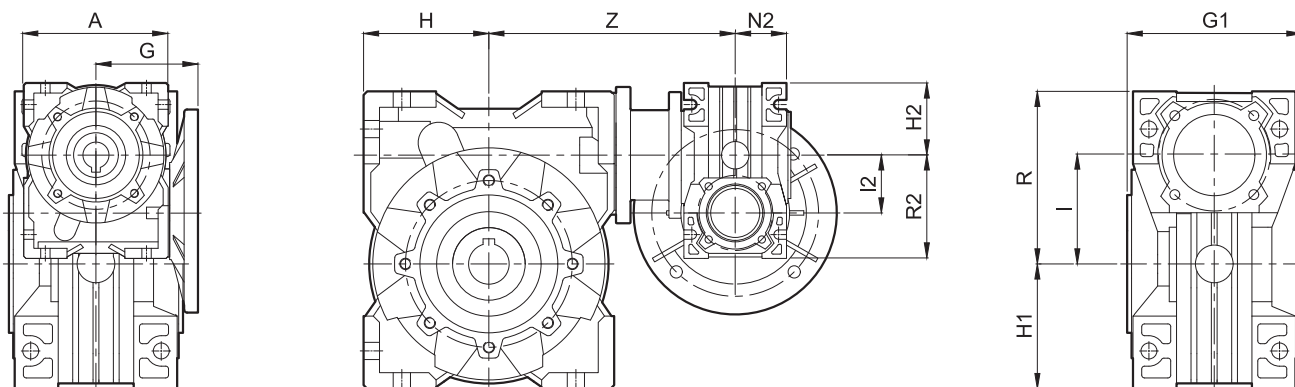
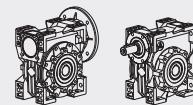

	A	G	G1	H	H1	I	R	H2	I2	N2	R2	Z
DS040-DS030	80	55	78	50	50	40	71,5	40	30	29	57	122
DS050-DS030	80	55	92	60	60	50	84	40	30	29	57	132
DS063-DS030	80	55	112	72	72	63	102	40	30	29	57	145
DS063-DS040	100	70	112	72	72	63	102	50	40	36,5	71,5	140,5
DS075-DS040	100	70	120	86	89	75	119	50	40	36,5	71,5	167,5
DS090-DS040	100	70	140	103	103	90	135	50	40	36,5	71,5	184,5
DS063-DS050	120	70	112	72	72	63	102	60	50	43,5	84	156,5
DS075-DS050	120	80	120	86	89	75	119	60	50	43,5	84	195,5
DS090-DS050	120	80	140	103	103	90	135	60	50	43,5	84	205
DS110-DS050	120	80	155	127,5	127,5	110	167,5	60	50	43,5	84	226
DS075-DS063	144	109	120	86	89	75	119	72	63	53	107	195,5
DS090-DS063	144	109	140	103	103	90	135	72	63	53	107	214
DS110-DS063	144	109	155	127,5	127,5	110	167,5	72	63	53	107	237
DS130-DS063	144	109	170	147,5	147,5	130	187,5	72	63	53	107	245
DS150-DS063	144	109	200	170	170	150	230	72	63	53	107	275

	D	bm	tm	T	G1
DS040-DS030	18	6	20,8	26	78
DS050-DS030	25	8	28,3	30	92
DS063-DS030	25	8	28,3	36	112
DS063-DS040					
DS063-DS050					
DS075-DS040	28	8	31,3	40	120
DS075-DS050					
DS075-DS063					
DS090-DS040	35	10	38,3	45	140
DS090-DS050					
DS090-DS063					
DS110-DS050	42	12	45,3	50	155
DS110-DS063					
DS130-DS063	45	14	48,8	60	170
DS150-DS063	50	14	53,8	72,5	200

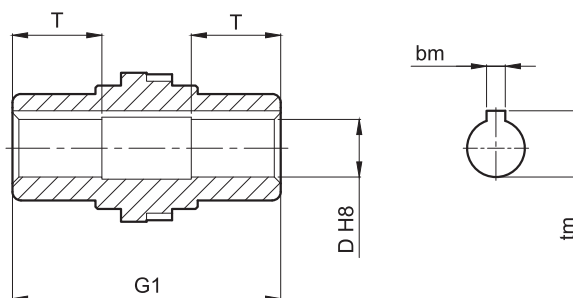

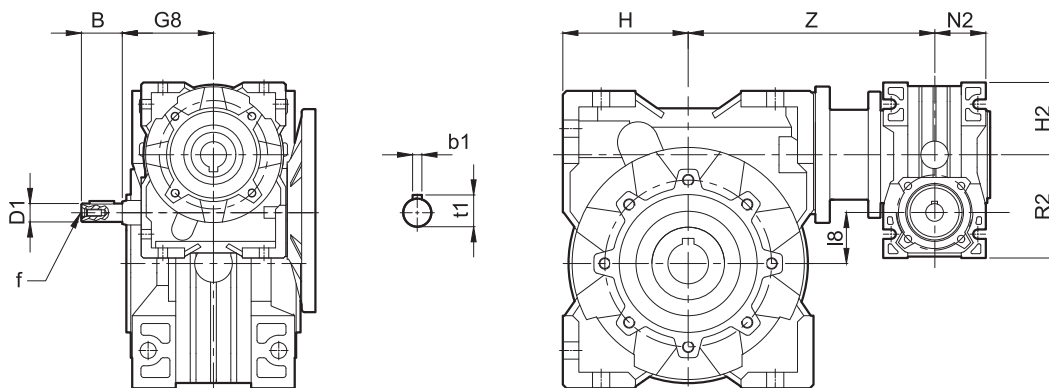
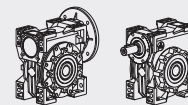

	B	G8	D1	f	b1	t1	H	H2	l8	N2	R2	Z
DS040-DSV030	20	51	9	-	3	10,2	50	40	10	29	57	122
DS050-DSV030	20	51	9	-	3	10,2	60	40	20	29	57	132
DS063-DSV030	20	51	9	-	3	10,2	72	40	33	29	57	145
DS050-DSV040	23	60	11	-	4	12,5	60	50	10	36,5	71,5	140,5
DS063-DSV040	23	60	11	-	4	12,5	72	50	23	36,5	71,5	156,5
DS075-DSV040	23	60	11	-	4	12,5	86	50	35	36,5	71,5	167,5
DS090-DSV040	23	60	11	-	4	12,5	103	50	50	36,5	71,5	184,5
DS090-DSV050	30	74	14	M6	5	16	103	60	40	43,5	84	205
DS110-DSV050	30	74	14	M6	5	16	127,5	60	60	43,5	84	226
DS110-DSV063	40	90	19	M6	6	21,5	127,5	72	47	53	107	237
DS130-DSV063	40	90	19	M6	6	21,5	147,5	72	67	53	107	245
DS150-DSV063	40	90	19	M6	6	21,5	170	72	87	53	107	275

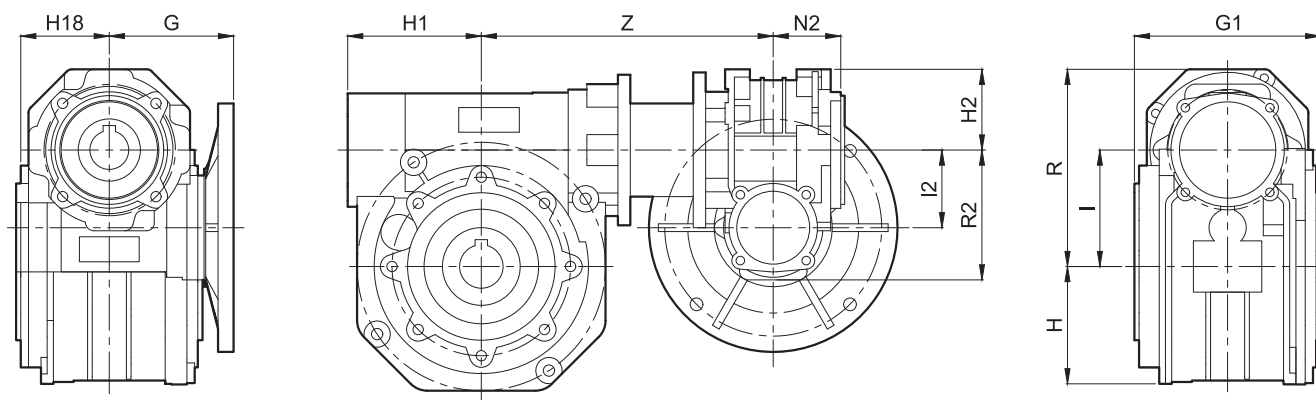
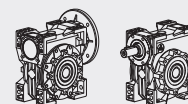

	H1B	G	G1	H	H1	I	R	H2	I2	N2	R2	Z
DY040-DY030	40	55	78	42	50	40	70	40	30	29	57	122
DY050-DY040	40	55	92	52	60	50	84	40	30	29	57	132
DY063-DY030	40	55	112	66	72	63	102	40	30	29	57	145
DY075-DY040	50	70	120	80	86	63	117	50	40	36,5	71,5	167,5
DY090-DY040	50	70	140	97	103	90	133	50	40	36,5	71,5	184,5
DY090-DY050	60	80	140	97	103	90	133	60	50	43,5	84	205

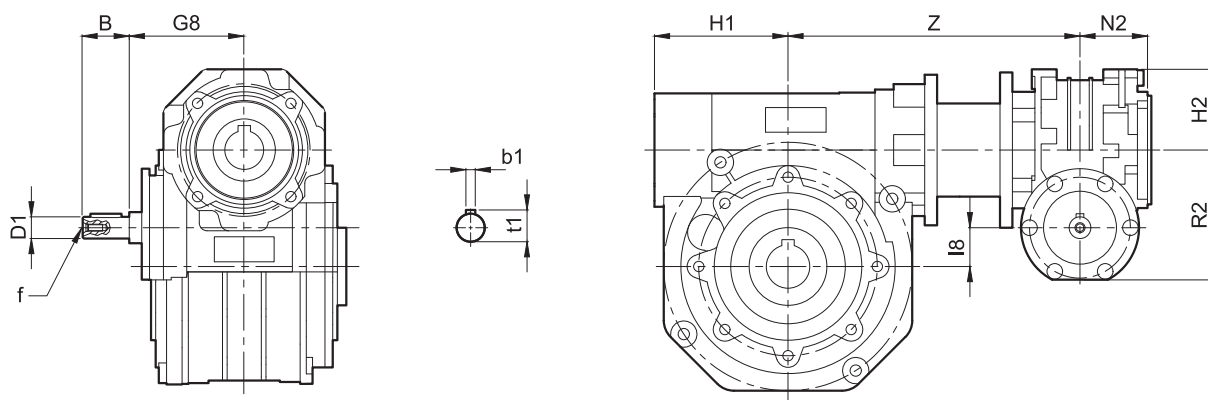
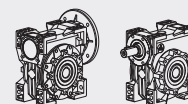

	B	G8	D1	f	b1	t1	H1	H2	l8	N2	R2	Z
DY040-DYV030	20	51	9	-	3	10,2	50	40	10	29	57	122
DY050-DYV030	20	51	9	-	3	10,2	60	40	20	29	57	132
DY063-DYV030	20	51	9	-	3	10,2	72	40	33	29	57	145
DY075-DYV040	23	60	11	-	4	12,5	86	50	35	36,5	71,5	167,5
DY090-DYV040	23	60	11	-	4	12,5	103	50	50	36,5	71,5	184,5
DY090-DYV050	30	74	14	M6	5	16	103	60	40	43,5	84	205

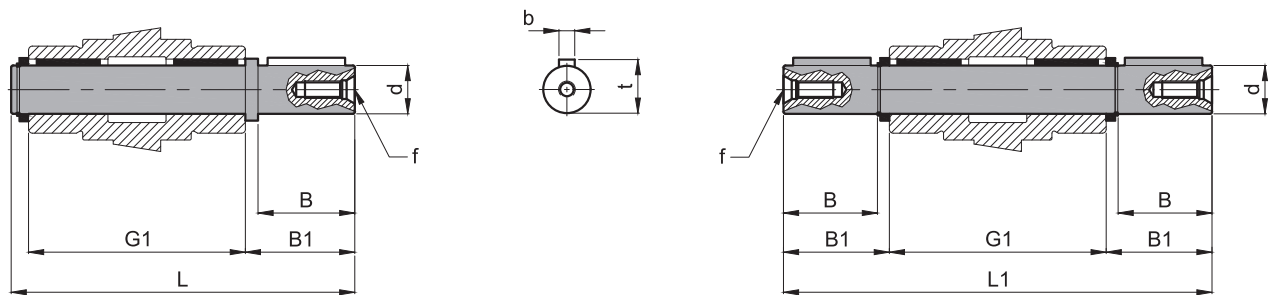
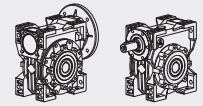

	d	B	B1	G1	L	L1	f	b	t
DS030	14 j6	30	32,5	63	102	128	M6	5	16
DS040	18 j6	40	43	78	128	164	M6	6	20,5
DS050	25 j6	50	53,5	92	153	199	M10	8	28
DS063	25 j6	50	53,5	112	173	219	M10	8	28
DS075	28 j6	60	63,5	120	192	247	M10	8	31
DS090	35 j6	80	84,5	140	234	309	M12	10	38
DS110	42 j6	80	84,5	155	249	324	M16	12	45
DS130	45 j6	80	85	170	265	340	M16	14	48,5
DS150	50 j6	82	87	200	297	374	M16	14	53,5

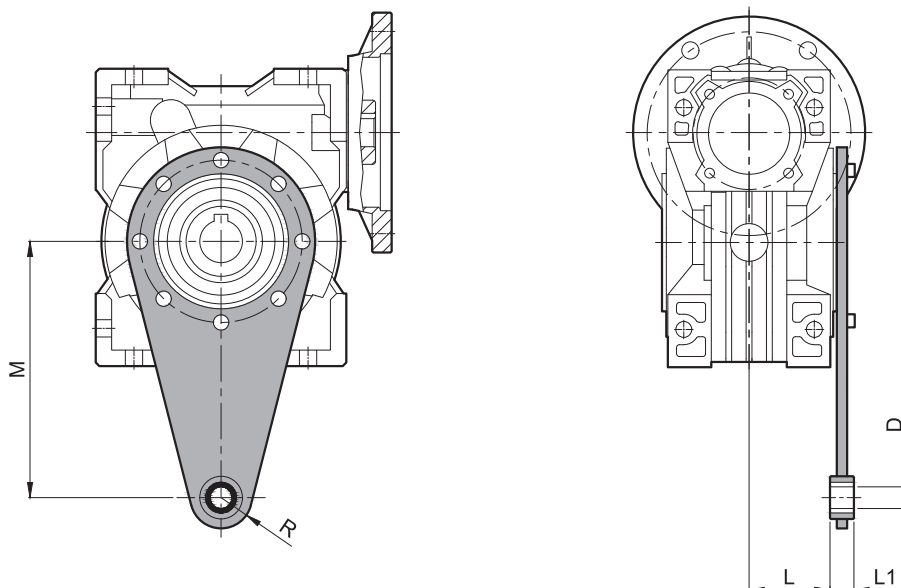
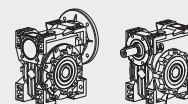

	M	R	L	L1	D
DS030	85	15	24	8	8
DS040	100	18	31,5	10	10
DS050	100	18	38,5	10	10
DS063	150	18	49	10	10
DS075	200	30	47,5	20	20
DS090	200	30	57,5	20	20
DS110	250	35	62	25	25
DS130	250	35	69	25	25
DS150	250	35	84	25	25

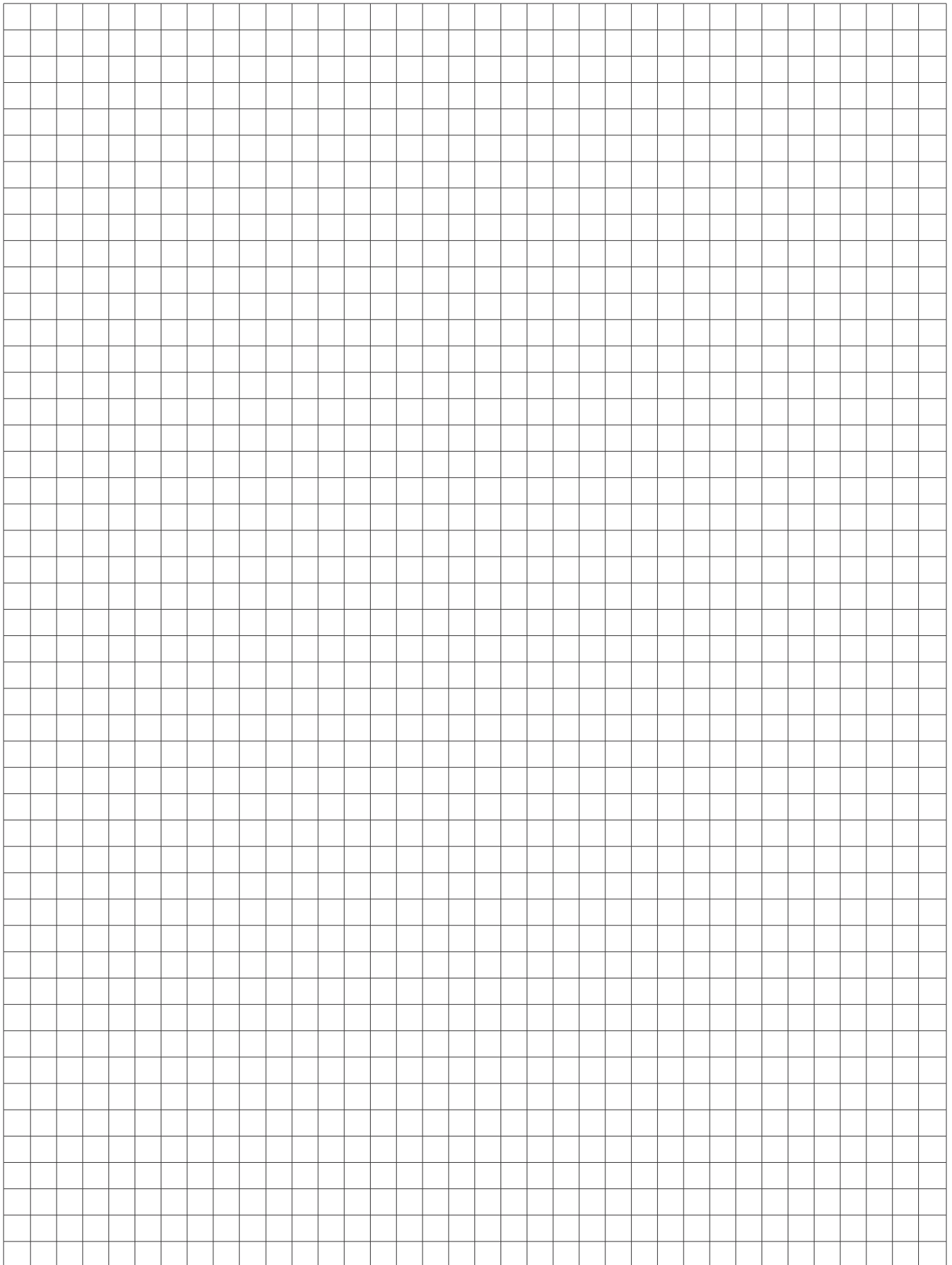

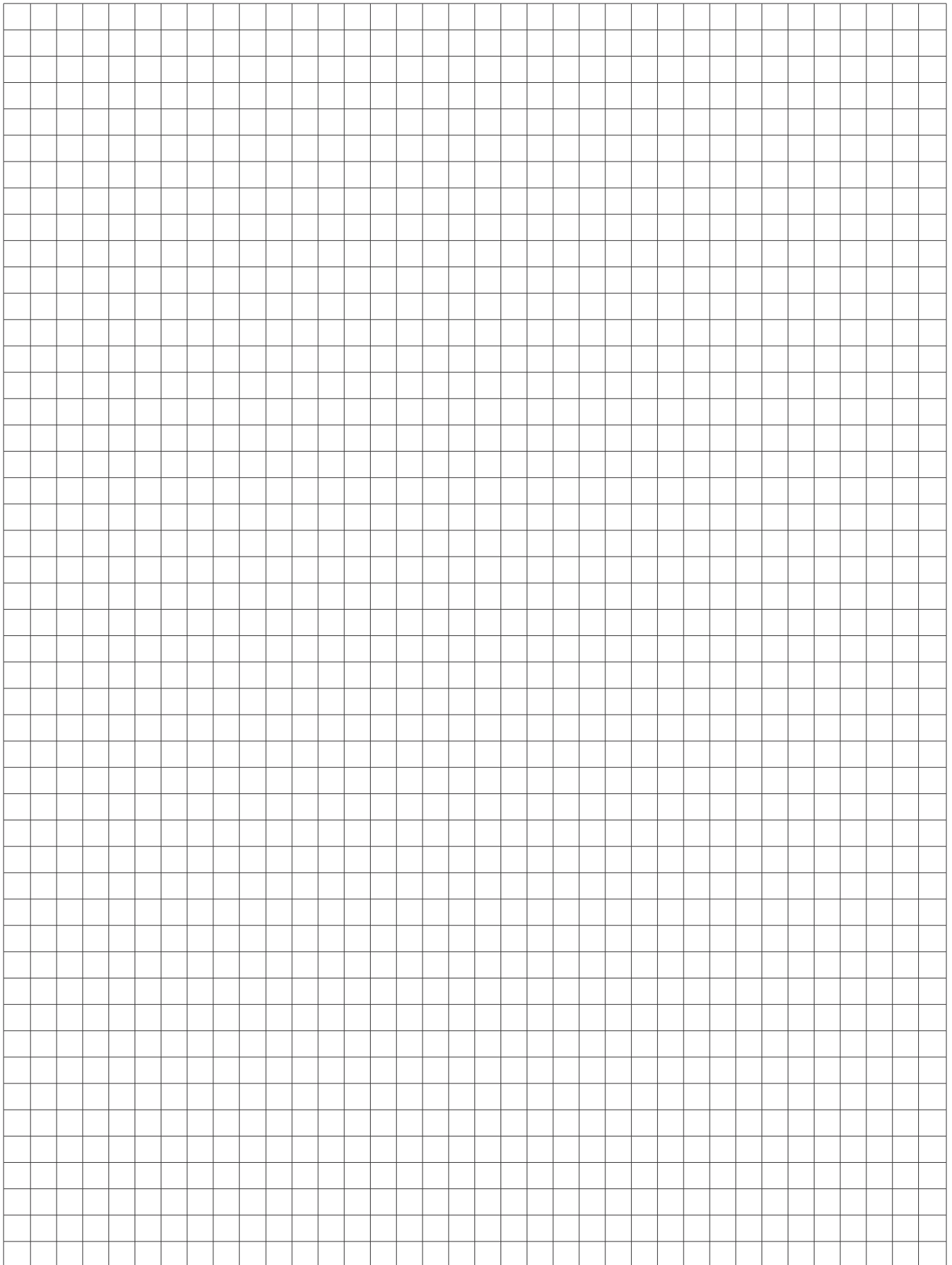

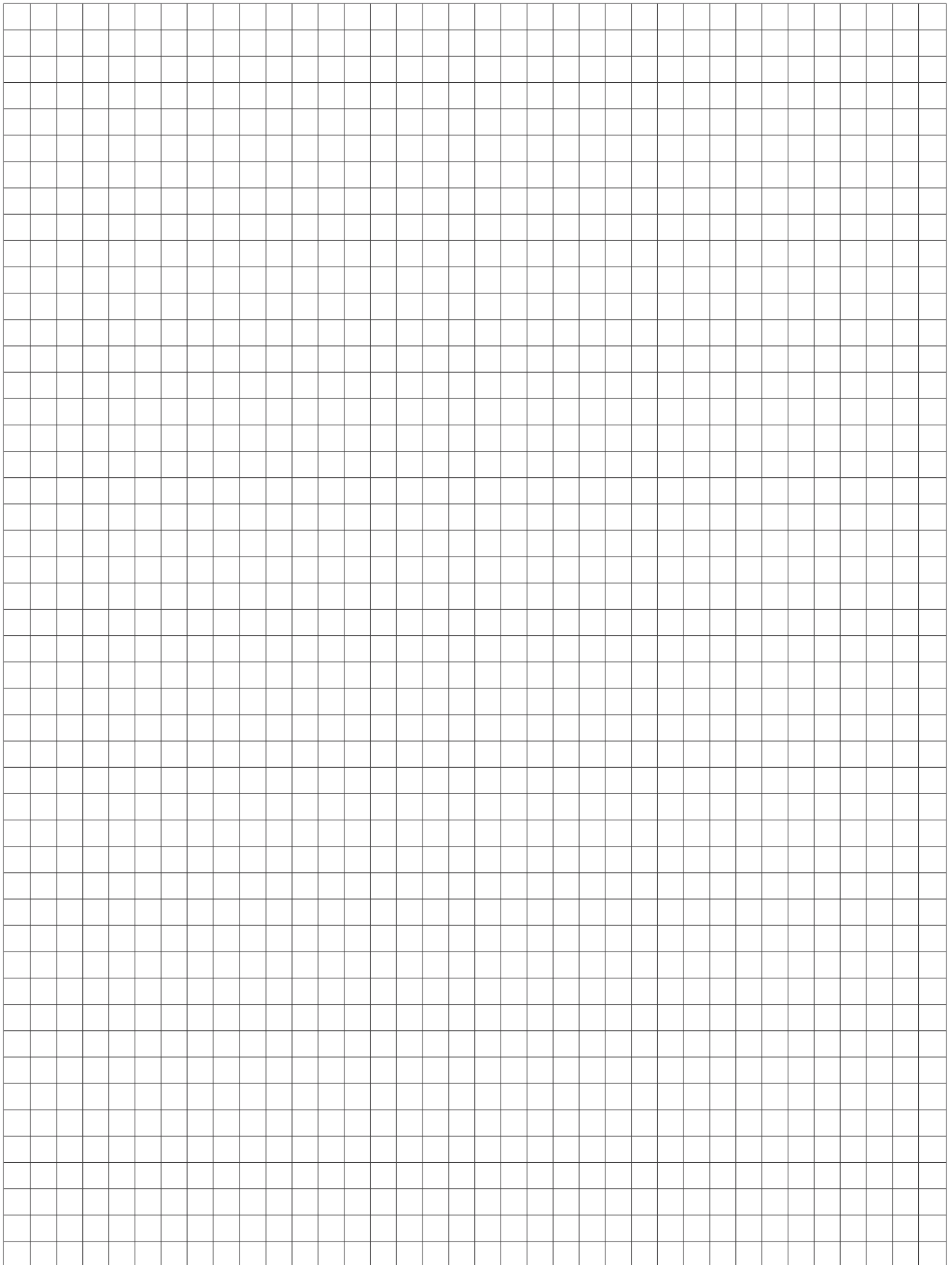



 **dinamik**
motor redüktör

İstanbul Merkez / İstanbul Head Office
İkitelli OSB, Metal-İş San. Sit. 12. Blok No: 41
34490 Başakşehir / İSTANBUL
Tel : +90 212 576 73 73

İzmir Fabrika / İzmir Factory
Tire OSB 3. Yol Sokak No: 21
35900 / İZMİR
Tel : +90 232 513 50 30

Ankara Şube / Ankara Branch
1274. Cadde No: 9 Ostim 06347
Yenimahalle / ANKARA
Tel : +90 312 395 20 30

www.dinamikmotor.com.tr