

Top 100
Global
Innovator
for 10 years

Standard AC Drive S100

0.4~2.2kW(0.5~3HP) 1-Phase 200~240Volts
0.4~15kW(0.5~20HP) 3-Phase 200~240Volts
0.4~75kW(0.5~100HP) 3-Phase 380~480Volts
IP66 NEMA4X 0.4~2.2kW(0.5~3HP) 1-phase 200V~240Volts
IP66 NEMA4X 0.4~15kW(0.5~20HP) 3-Phase 200~240Volts
IP66 NEMA4X 0.4~22kW(0.5~30HP) 3-Phase 380~480Volts



LS ELECTRIC



Contents

- 04 S100 Features
- 10 IP66/NEMA 4X
- 12 Model and Type
- 14 Specifications
- 17 Wiring / Terminal Configuration
- 21 Keypad Functions
- 28 Peripheral Devices
- 32 Dimensions



High-performance
Standard Drive

S100

Strong Power with a Compact Size !

Powerful sensorless control, and a diverse range of user friendly functions delivers added value to our customers. Meet the new standard drive S100 by LS for the global market.



Scan the QR code on your drive front and check the key use information

c  US  RoHS



Safety Functions

- Built-in safe torque off (STO)
- Redundant input circuit



Strong Performance

- Sensorless control functions
- Starting torque (200%/0.5Hz)



Suitable for Users

- Various field networks



Space Efficient Design

- Side-by-side installation
- Decreased dimensions



Standard Compliance

- Built-in EMC filter
- International standards



Specialized Features

S100 Improves User Convenience with Smart Copier.



RJ45
(Included if Smart Copiers are Purchased)

Smart Copier

User Convenience

Functions Without Power Input

The drive does not need to be powered when using the smart copier.

User Sequence Function

Simple PLC sequences can be operated with various function block combinations.

Multi Keypad Function

Multiple drives can be controlled and monitored with single keypad. (RS485 wiring required)

Simple Installation

Parameters saved in the smart copier can be downloaded to both the drive I/O and the control part.

LED Lamp Feedbacks

The run LED flickers during normal operation. The error LED flickers when events such as communication errors occur.

Read / Write Function of Parameters

Parameters can be copied/loaded from the drive to the smart copier and vice versa, simply with the keypad.

P2P Function Embedded

I/O input and output can be shared among master and slave drive (RS485 wiring required)

Smart Copier Flow Chart

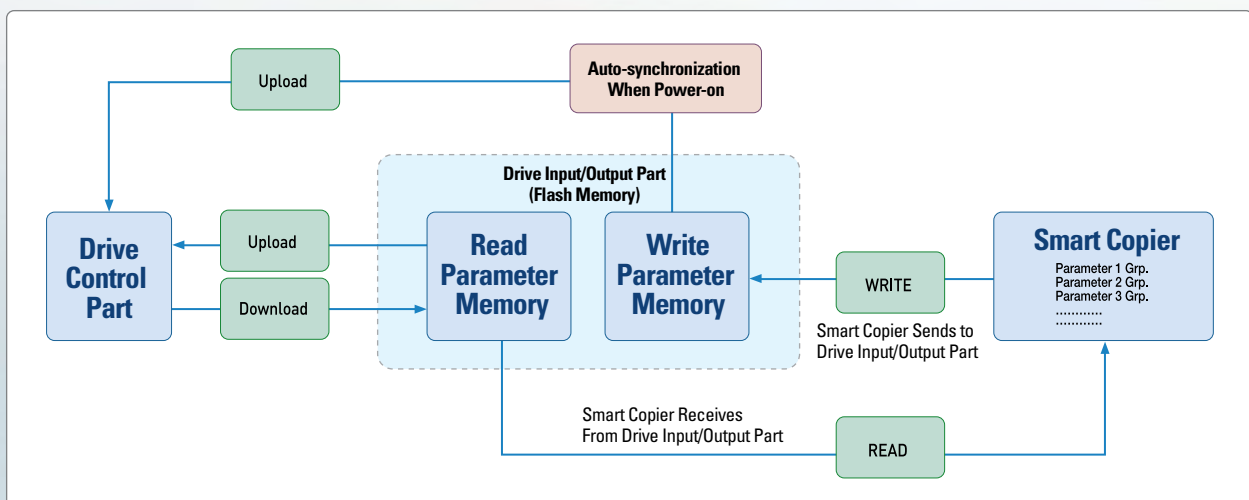



Strong Performance

S100 is a Drive with Enhanced Sensorless Control.



Graphic LCD can be used for parameter copy from drive to drive.

Powerful Sensorless Control

Starting torque of 200%/0.5Hz is produced and provides robust power in the low speed region. The motor auto-tuning function is optimized to maximize motor performance.

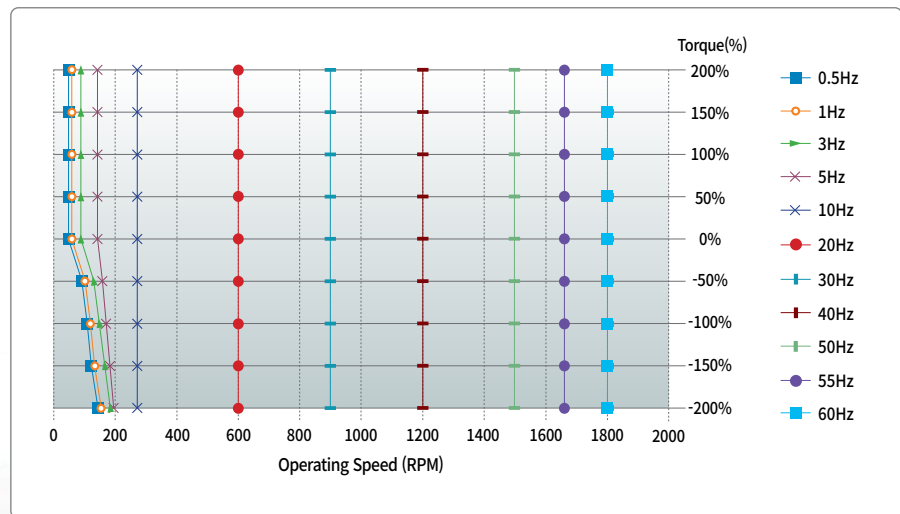

Flying Start Function

Drive capable of quick reliable smooth restarts into bi-directional rotating loads.

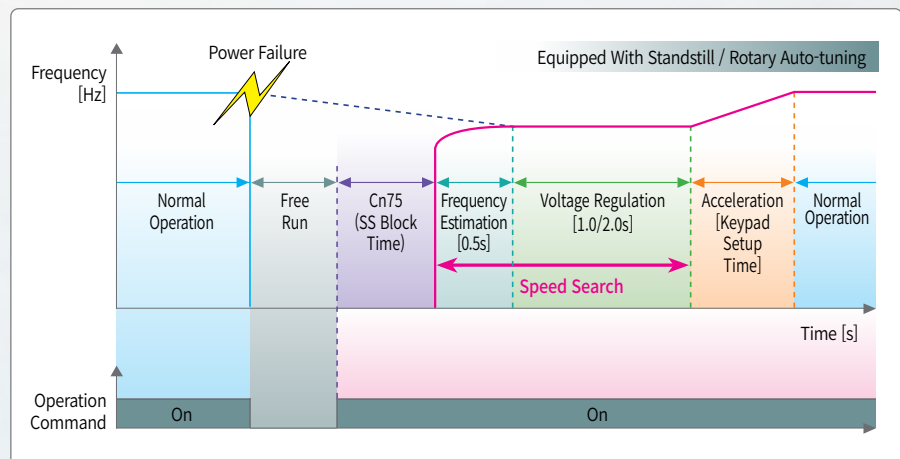



Suitable for Users

S100 Offers a Variety of Customer Conveniences to Compete in the Global Market.

Multi-Keypad Function

Single LCD keypad can be used to set up the parameters of a RS485 connected drives.

- ※ LCD keypad (same as iS7 model) enables handy parameter set up.
- ※ Multi language support will be available.

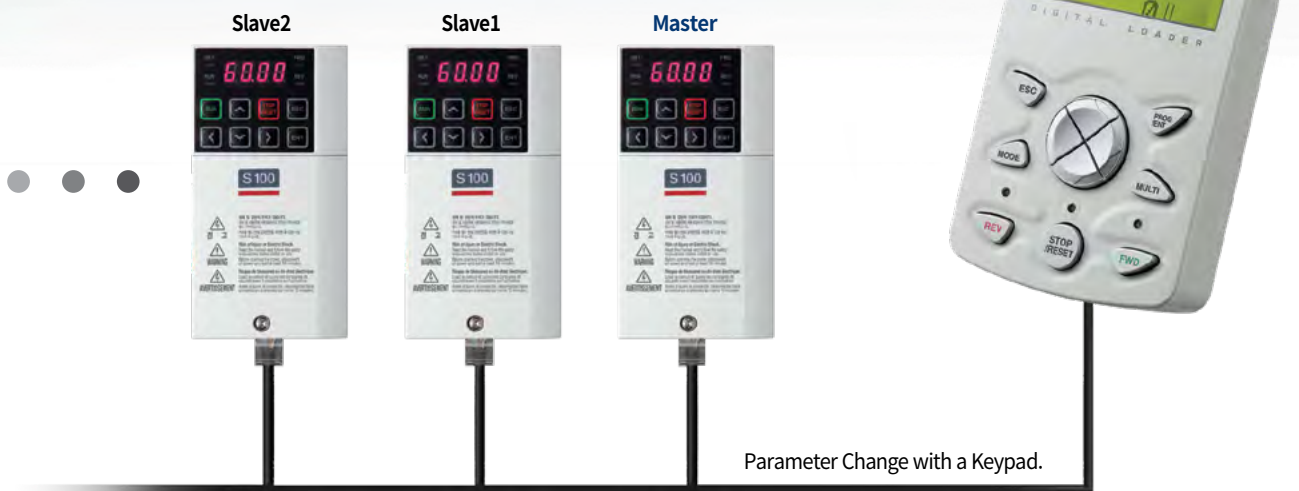

Various Field Bus Options Easy to Install and Use.

Possible to connect to a variety of fieldbus networks Easy maintenance and mounting

[Various Field Bus Options]

- | | |
|---------------|------------|
| ① Profibus-DP | ④ CANopen |
| ② Ethernet IP | ⑤ EtherCAT |
| ③ Modbus TCP | ⑥ PROFINet |



Conduit Kit

Acquired UL open type & enclosed type1 certification

- ※ UL open type is offered as default
- ※ UL enclosed type1 needs conduit kit(option) installation

Simple Cooling Fan Replacement

Replaceable fan without complete disassembly



Flange Type

The heat sink can be mounted outside of the panel in case the space is limited.



Extension I/O Option Card

- Relay output: 2ea (NO/NC selectable)
- Digital input: 3ea (NPN/PNP selectable)
- Analog I/O: 2ea/1ea each





DriveView9 Connection with RJ45 Port

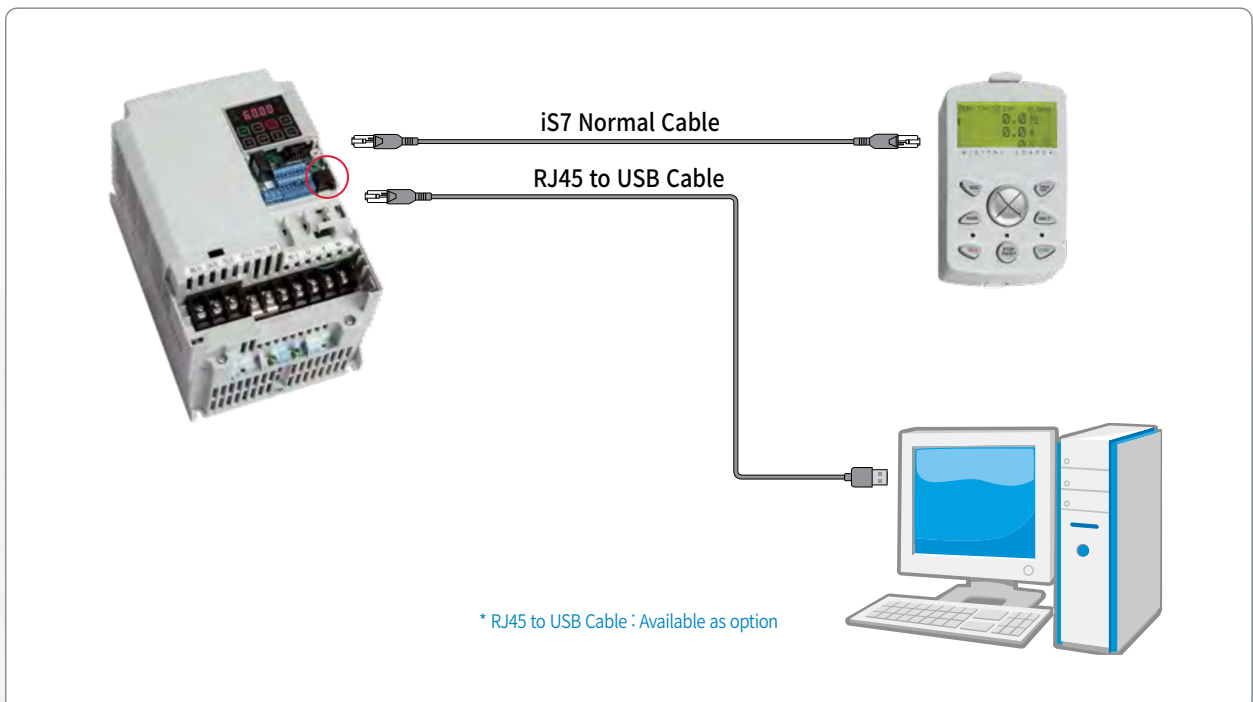



Space Efficient Design

S100 Increases Efficiency of the Control Panel.

Smaller Size

Main components have been optimally designed through thermal analysis and 3D design to reduce the dimension up to 60% compared to iG5A.

Size Reduction

60%

400V 11kW Basis



Side-by-side Installation

Minimized distance between drives enables panel size reduction for multiple drives installation.

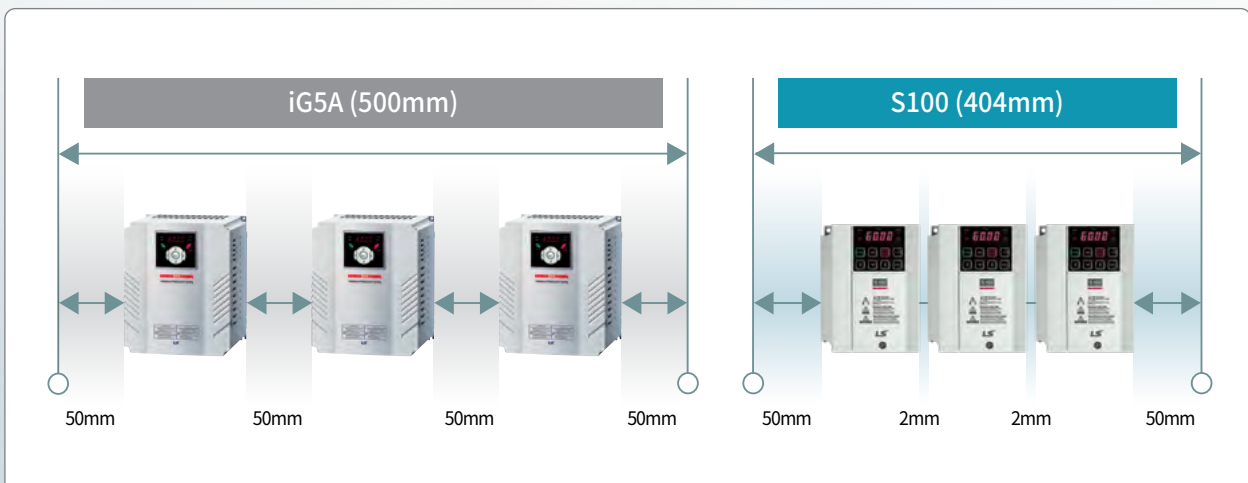



Standard Compliance

S100 Has Built-in Safety Functions Suitable for Modern Safety Standards.

Built-in DC Reactor

Effective in improving power factor and decreasing THD.

※ 3-phase 400V 30~75kW

Built-in EMC Filter

- Meets the electrical noise reduction regulation.
- Related standards: 2nd Environment/Category C3(Class A)
- CE standard is certified

※ 1-phase 200V 0.4~2.2kW (C2) / 3-phase 400V 0.4~45kW (C3)

Dual Rating Operation

Designed to be used for heavy and normal duty applications.

- Overload capacity
 - Heavy duty operation: 150% of rated current, 60 seconds
 - Normal duty operation: 120% of rated current, 60 seconds

※ Excludes IP66/NEMA 4X

Built-in Safe Torque Off(STO)

The Safety input function meets EN ISO 13849-1 PLd and EN 61508 SIL2 (EN60204-1, stop category 0). This feature is standard and enables compliance with current safety standards.



Global Compliance

Global standard compliance



Selectable Rotary / Standstill Auto-tuning

Standstill or rotary auto-tuning options are available as standard to find motor constants with or without rotating the motor for optimized motor performance.

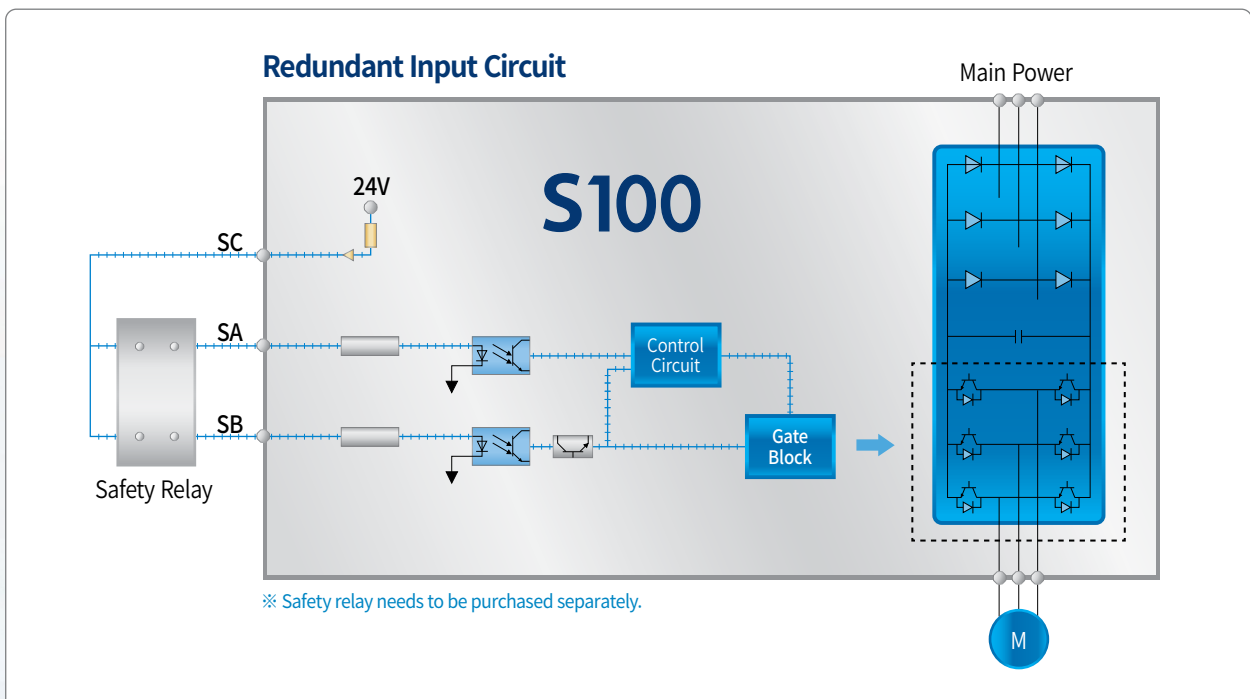

new



The Drive for Harsh Ambient Conditions.

S100 IP66/NEMA 4X Series

Protected Against Foreign Substances Such as Fine Dust and High Pressure Water Spray.

- Satisfies NEMA standard type 4X for indoor use.
- Satisfies IEC 60529 standard IP66
- 1Ø 200V 0.4~2.2kW / 3Ø 200V 0.4~15kW / 3Ø 400V 0.4~22kW
- PDS / Non-PDS (PDS; Power Disconnect Switch)



IP66/NEMA 4X

Standard I/O

Motor Rating	1-Phase 200V		3-Phase 200V		3-Phase 400V	
	IP20	IP66 ¹⁾	IP20	IP66 ¹⁾	IP20	IP66 ¹⁾
0.4 kW	LSLV0004S100-1E0(F)NS	LSLV0004S100-1EX(F)NS	LSLV0004S100-2EONNS	LSLV0004S100-2EXNNS	LSLV0004S100-4E0(F)NS	LSLV0004S100-4EXFNS
0.75 kW	LSLV0008S100-1E0(F)NS	LSLV0008S100-1EX(F)NS	LSLV0008S100-2EONNS	LSLV0008S100-2EXNNS	LSLV0008S100-4E0(F)NS	LSLV0008S100-4EXFNS
1.5 kW	LSLV0015S100-1E0(F)NS	LSLV0015S100-1EX(F)NS	LSLV0015S100-2EONNS	LSLV0015S100-2EXNNS	LSLV0015S100-4E0(F)NS	LSLV0015S100-4EXFNS
2.2 kW	LSLV0022S100-1E0(F)NS	LSLV0022S100-1EX(F)NS	LSLV0022S100-2EONNS	LSLV0022S100-2EXNNS	LSLV0022S100-4E0(F)NS	LSLV0022S100-4EXFNS
3.7 kW			LSLV0037S100-2EONNS	LSLV0037S100-2EXNNS	LSLV0037S100-4E0(F)NS	LSLV0037S100-4EXFNS
4.0 kW			LSLV0040S100-2EONNS	LSLV0040S100-2EXNNS	LSLV0040S100-4E0(F)NS	LSLV0040S100-4EXFNS
5.5 kW			LSLV0055S100-2EONNS	LSLV0055S100-2EXNNS	LSLV0055S100-4E0(F)NS	LSLV0055S100-4EXFNS
7.5 kW			LSLV0075S100-2EONNS	LSLV0075S100-2EXNNS	LSLV0075S100-4E0(F)NS	LSLV0075S100-4EXFNS
11 kW			LSLV0110S100-2EONNS	LSLV0110S100-2EXNNS	LSLV0110S100-4E0(F)NS	LSLV0110S100-4EXFNS
15 kW			LSLV0150S100-2EONNS	LSLV0150S100-2EXNNS	LSLV0150S100-4E0(F)NS	LSLV0150S100-4EXFNS
18.5 kW					LSLV0185S100-4E0(F)NS	LSLV0185S100-4EXFNS
22 kW					LSLV0220S100-4E0(F)NS	LSLV0220S100-4EXFNS
30 kW					LSLV0300S100-4CO(F)DS	
37 kW					LSLV0370S100-4CO(F)DS	
45 kW					LSLV0450S100-4CO(F)DS	
55 kW					LSLV0550S100-4CONDS	
75 kW					LSLV0750S100-4CONDS	

¹⁾ Extension I/O option needs to be purchased separately

* (F): Built-in EMC or Non-EMC type selectable

* 55-75kW satisfies EMC class 3

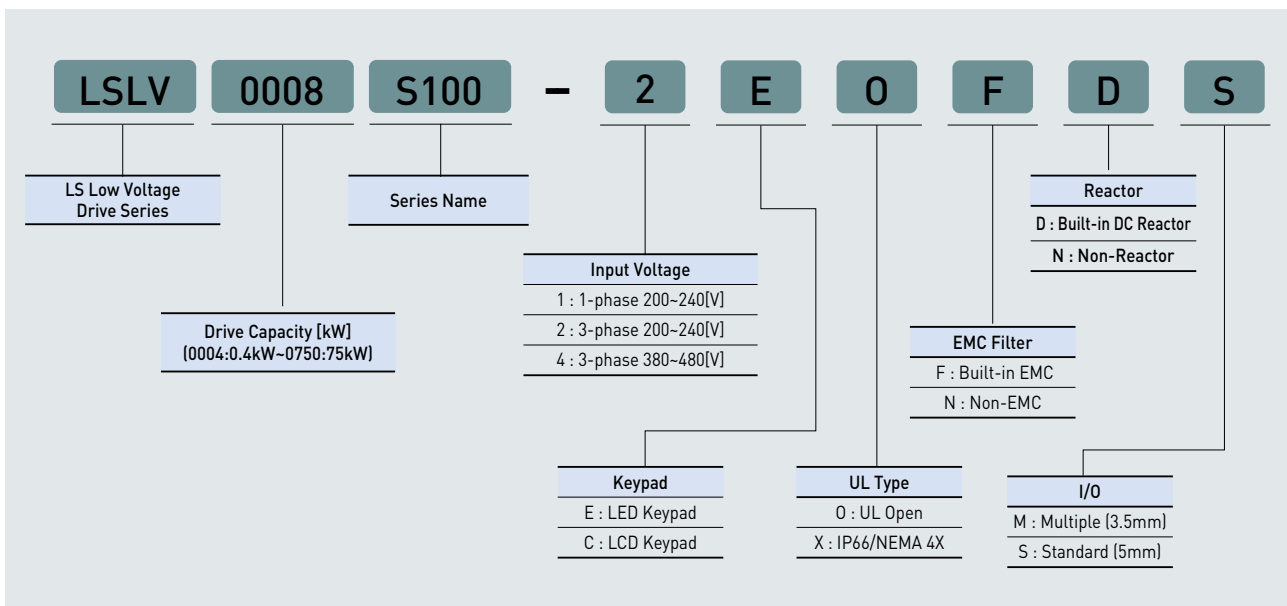

Multiple I/O

Motor rating	1-Phase 200V	3-Phase 200V	3-Phase 400V
	IP20	IP20	IP20
0.4 kW	LSLV0004S100-1E0(F)NM	LSLV0004S100-2EONNM	LSLV0004S100-4E0(F)NM
0.75 kW	LSLV0008S100-1E0(F)NM	LSLV0008S100-2EONNM	LSLV0008S100-4E0(F)NM
1.5 kW	LSLV0015S100-1E0(F)NM	LSLV0015S100-2EONNM	LSLV0015S100-4E0(F)NM
2.2 kW	LSLV0022S100-1E0(F)NM	LSLV0022S100-2EONNM	LSLV0022S100-4E0(F)NM
3.7 kW		LSLV0037S100-2EONNM	LSLV0037S100-4E0(F)NM
4.0 kW		LSLV0040S100-2EONNM	LSLV0040S100-4E0(F)NM
5.5 kW		LSLV0055S100-2EONNM	LSLV0055S100-4E0(F)NM
7.5 kW		LSLV0075S100-2EONNM	LSLV0075S100-4E0(F)NM
11 kW		LSLV0110S100-2EONNM	LSLV0110S100-4E0(F)NM
15 kW		LSLV0150S100-2EONNM	LSLV0150S100-4E0(F)NM
18.5 kW			LSLV0185S100-4E0(F)NM
22 kW			LSLV0220S100-4E0(F)NM

* (F): Built-in EMC or Non-EMC type selectable

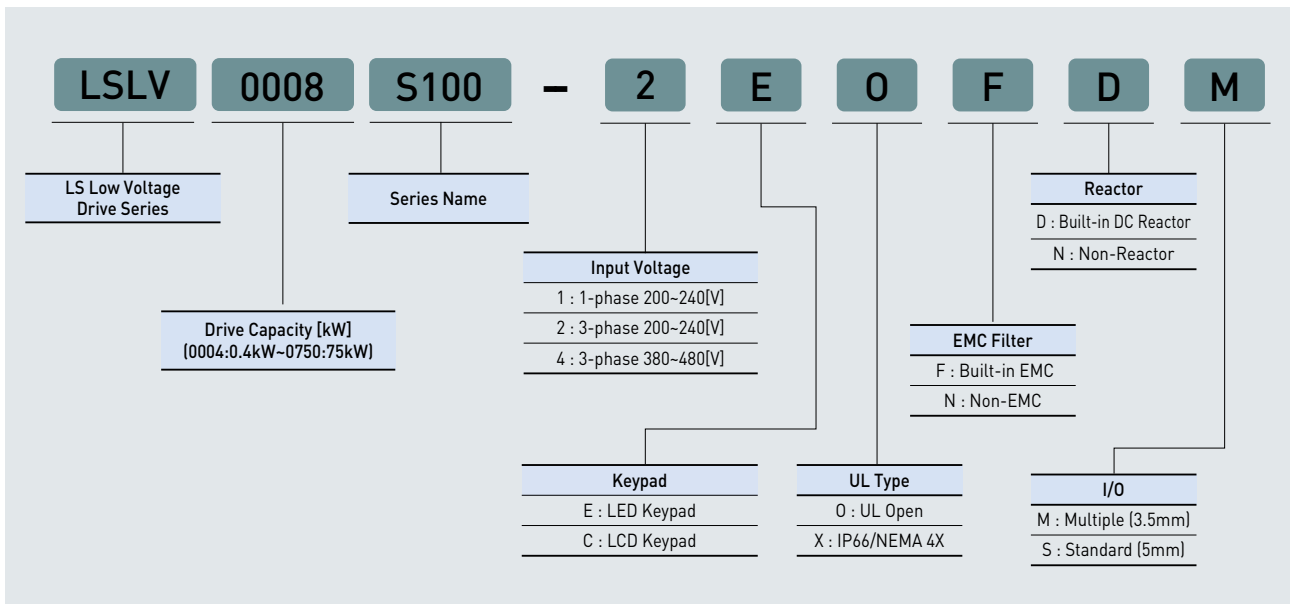

1-Phase 200V (0.4~2.2kW)

LSLV□□□□S100-1□□□□□			0004	0008	0015	0022	
Motor Rating	Heavy Duty(HD)	HP	0.5	1.0	2.0	3.0	
		kW	0.4	0.75	1.5	2.2	
	Normal Duty(ND)	HP	1.0	2.0	3.0	5.0	
		kW	0.75	1.5	2.2	3.7	
Output Rating	Capacity [kVA]	Heavy Duty(HD)	1.0	1.9	3.0	4.2	
		Normal Duty(ND)	1.2	2.3	3.8	4.6	
	Rated Current [A]	Heavy Duty(HD)	2.5	5.0	8.0	11.0	
		Normal Duty(ND)	3.1	6.0	9.6	12.0	
	Frequency [Hz]	0~400Hz (IM Sensorless: 0~120[Hz])					
Voltage [V]	3-phase 200~240V						
Input Rating	Voltage [V]	1-phase 200~240VAC (-15% ~ +10%)					
	Frequency [Hz]	50~60Hz(±5%)					
	Rated Current [A]	Heavy Duty(HD)	4.4	9.3	15.6	21.7	
		Normal Duty(ND)	5.8	11.7	19.7	24.0	
Weight [kg]	Non-EMC Filter Type		2.0/0.9	2.9/1.3	3.3/1.5	4.4/2.0	
	EMC Filter Type		2.5/1.1	3.4/1.6	3.9/1.8	4.9/2.2	
	IP66 Type(EMC)		8.2/3.7	11.7/5.3	12.1/5.5	12.4/5.6	
	IP66 Type(Non-EMC)		7.9/3.6	11.5/5.2	11.9/5.4	12.1/5.5	

3-Phase 200V (0.4~15kW)

LSLV□□□□S100-2□□□□□			0004	0008	0015	0022	0037	0040	0055	0075	0110	0150	
Motor Rating	Heavy Duty(HD)	HP	0.5	1.0	2.0	3.0	5.0	5.4	7.5	10.0	15.0	20.0	
		kW	0.4	0.75	1.5	2.2	3.7	4.0	5.5	7.5	11.0	15.0	
	Normal Duty(ND)	HP	1.0	2.0	3.0	5.0	5.4	7.5	10.0	15.0	20.0	25.0	
		kW	0.75	1.5	2.2	3.7	4.0	5.5	7.5	11.0	15.0	18.5	
Output Rating	Capacity [kVA]	Heavy Duty(HD)	1.0	1.9	3.0	4.2	6.1	6.5	9.1	12.2	17.5	22.9	
		Normal Duty(ND)	1.2	2.3	3.8	4.6	6.9	6.9	11.4	15.2	21.3	26.3	
	Rated Current [3-Phase Input] [A]	Heavy Duty(HD)	2.5	5.0	8.0	11.0	16.0	17.0	24.0	32.0	46.0	60.0	
		Normal Duty(ND)	3.1	6.0	9.6	12.0	18.0	18.0	30.0	40.0	56.0	69.0	
	Rated Current [Single-phase Input] [A]	Heavy Duty(HD)	1.5	2.8	4.6	6.1	8.8	9.3	13.0	18.0	26.0	33.0	
		Normal Duty(ND)	1.8	3.3	5.7	6.6	9.9	9.9	16.0	22.0	31.0	38.0	
	Frequency [Hz]	0~400Hz (IM Sensorless: 0~120[Hz])											
Voltage [V]	3-phase 200~240V												
Input Rating	Voltage [V]	3-phase 200~240VAC (-15% ~ +10%) / Single-Phase 240VAC (-5%~+10%)											
	Frequency [Hz]	50~60Hz(±5%) (In case of single phase input, input frequency is only 60Hz (±5%))											
	Rated Current [A]	Heavy Duty(HD)	2.2	4.9	8.4	11.8	17.5	18.5	25.8	34.9	50.8	66.7	
		Normal Duty(ND)	3.0	6.3	10.8	13.1	19.4	19.4	32.7	44.2	62.3	77.2	
Weight [kg]	Non-EMC Filter Type		2.0/0.9	2.0/0.9	2.9/1.3	3.3/1.5	4.4/2.0	4.4/2.0	6.8/3.1	6.8/3.1	9.7/4.4	15.2/6.9	
	IP66 Type(Non-EMC)		7.9/3.6	7.9/3.6	11.5/5.2	11.9/5.4	12.1/5.5	12.1/5.5	19.4/8.8	19.4/8.8	20.7/9.4	26.2/11.9	

* Maximum applicable capacity is indicated in case of using a 4-pole standard motor (200 and 400V classes are based on 220 and 440V, respectively).
 * For the rated capacity, 200 and 400V class input capacities are based on 220 and 440V, respectively.
 * The rated output current is limited depending on the setup of carrier frequency (CN-04).
 * The output voltage becomes 20~40% lower during no-load operations to protect the drive from the impact of the motor closing and opening (0.4~4.0kW models only).
 * Dual rating is supported except IP66/NEMA 4X
 * IP66 products do not support light load operation.

3-Phase 400V (0.4~22kW)

LSLV□□□□S100-4□□□□□			0004	0008	0015	0022	0037	0040	0055	0075	0110	0150	0185	0220											
Motor Rating	Heavy Duty(HD)	HP	0.5	1.0	2.0	3.0	5.0	5.4	7.5	10.0	15.0	20.0	25.0	30.0											
		kW	0.4	0.75	1.5	2.2	3.7	4.0	5.5	7.5	11.0	15.0	18.5	22.0											
	Normal Duty(ND)	HP	1.0	2.0	3.0	5.0	5.4	7.5	10.0	15.0	20.0	25.0	30.0	40.0											
		kW	0.75	1.5	2.2	3.7	4.0	5.5	7.5	11.0	15.0	18.5	22.0	30.0											
Output Rating	Capacity [kVA]	Heavy Duty(HD)	1.0	1.9	3.0	4.2	6.1	6.9	9.1	12.2	18.3	22.9	29.7	34.3											
		Normal Duty(ND)	1.5	2.4	3.9	5.3	7.6	7.6	12.2	17.5	22.9	29.0	33.5	44.2											
	Rated Current [3-Phase Input] [A]	Heavy Duty(HD)	1.3	2.5	4.0	5.5	8.0	9.0	12.0	16.0	24.0	30.0	39.0	45.0											
		Normal Duty(ND)	2.0	3.1	5.1	6.9	10.0	10.0	16.0	23.0	30.0	38.0	44.0	58.0											
	Rated Current [Single-phase Input] [A]	Heavy Duty(HD)	0.8	1.5	2.3	3.1	4.8	5.4	7.1	9.5	15.0	18.0	23.0	27.0											
		Normal Duty(ND)	1.3	1.9	3.0	3.9	5.9	5.9	9.5	14.0	18.0	23.0	27.0	35.0											
	Frequency [Hz]	0~400Hz (IM Sensorless: 0~120[Hz])																							
Voltage [V]	3-phase 380~480V																								
Input Rating	Voltage [V]	3-phase 380~480VAC (-15% ~ +10%) / Single-phase 480VAC (-5%~+10%)																							
	Frequency [Hz]	50~60Hz(±5%) (In case of single phase input, input frequency is only 60Hz (±5%))																							
	Rated Current [A]	Heavy Duty(HD)	1.1	2.4	4.2	5.9	8.7	9.8	12.9	17.5	26.5	33.4	43.6	50.7											
Normal Duty(ND)		2.0	3.3	5.5	7.5	10.8	10.8	17.5	25.4	33.4	42.5	49.5	65.7												
Weight [kg]	EMC Filter Type	2.6/1.2		2.6/1.2		3.9/1.8		4.0/1.8		4.9/2.2		4.9/2.2		7.3/3.3		7.5/3.4		10.1/4.6		10.5/4.8		16.5/7.5		16.5/7.5	
	Non-EMC Filter Type	2.0/0.9		2.0/0.9		2.9/1.3		3.3/1.5		4.4/2.0		4.4/2.0		19.4/8.8		19.6/8.9		21.2/9.6		21.6/9.8		27.3/12.4		27.3/12.4	
	IP66 Type(EMC)	8.2/3.7		8.2/3.7		11.7/5.3		12.1/5.5		12.4/5.6		12.4/5.6		19.0/8.6		19.2/8.7		20.7/9.4		21.2/9.6		26.9/12.2		26.9/12.2	
	IP66 Type(Non-EMC)	7.9/3.6		7.9/3.6		11.5/5.2		11.9/5.4		12.1/5.5		12.1/5.5		19.0/8.6		19.2/8.7		20.7/9.4		21.2/9.6		26.9/12.2		26.9/12.2	

3-Phase 400V (30~75kW)

LSLV□□□□S100-4□□□□□			0300	0370	0450	0550	0750
Motor Rating	Heavy Duty(HD)	HP	40.0	50.0	60.0	75.0	100.0
		kW	30.0	37.0	45.0	55.0	75.0
	Normal Duty(ND)	HP	50.0	60.0	75.0	100.0	120.0
		kW	37.0	45.0	55.0	75.0	90.0
Output Rating	Capacity [kVA]	Heavy Duty(HD)	46	57	69	84	116
		Normal Duty(ND)	55	67	78	106	126
	Rated Current [3-Phase Input] [A]	Heavy Duty(HD)	61.0	75.0	91.0	110.0	152.0
		Normal Duty(ND)	75.0	91.0	107.0	142.0	169.0
	Rated Current [Single-phase Input] [A]	Heavy Duty(HD)	32	39	47	57	78
		Normal Duty(ND)	39	47	55	73	87
Frequency [Hz]	0~400Hz (IM Sensorless: 0~120[Hz])						
Voltage [V]	3-phase 380~480V						
Input Rating	Voltage [V]	3-phase 380~480VAC (-15% ~ +10%) / Single-phase 480VAC (-5%~+10%)					
	Frequency [Hz]	50~60Hz(±5%) (In case of single phase input, input frequency is only 60Hz (±5%))					
	Rated Current [A]	Heavy Duty(HD)	56.0	69.0	85.0	103.0	143.0
Normal Duty(ND)		69.0	85.0	100.0	134.0	160.0	
Weight [kg]	EMC Filter Type	57/26	77/35	77/35	-	-	
	Non-EMC Filter Type	55/25	75/34	75/34	95/43	95/43	

* Maximum applicable capacity is indicated in case of using a 4-pole standard motor (200 and 400V classes are based on 220 and 440V, respectively).

* For the rated capacity, 200 and 400V class input capacities are based on 220 and 440V, respectively.

* The rated output current is limited depending on the setup of carrier frequency (CN-04).

* The output voltage becomes 20~40% lower during no-load operations to protect the drive from the impact of the motor closing and opening (0.4~4.0kW models only).

* Dual rating is supported except IP66/NEMA 4X

Control

Control Method	V/f, Slip compensation, Sensorless vector ¹⁾
Frequency Setting Resolution	Digital command: 0.01Hz / Analog command: 0.06Hz (maximum frequency: 60Hz)
Frequency Accuracy	1% of the maximum output frequency
V/F Pattern	Linear, Squared, User V/F
Overload Capacity	HD: 150% 1 minute, ND: 120% 1 minute
Torque Boost	Manual/Automatic torque boost

¹⁾ REQUEST - LS SALES PERSON FOR PM SENSORLESS FUNCTION.

Operation

Operation Mode	Keypad / Terminal / Communication option selectable	
Frequency Setting	Analog: -10~10[V], 0~10[V], 4~20[mA] / Digital: Keypad, Pulse train input	
Operation Function	PID control, 3-wire operation, Frequency limit, Second function, Anti-forward and reverse direction rotation, Commercial transition, Speed search, Power braking, Leakage reduction, Up-down operation, DC braking, Frequency jump, Slip compensation, Automatic restart, Automatic tuning, Energy buffering, Flux braking, Fire Mode	
Input	Multi-Function Terminal Standard I/O (5 Points) Multiple I/O (7 Points)	NPN (Sink) / PNP (Source) Selectable Function: Forward run, Reverse run, Reset, External trip, Emergency stop, Jog operation, Multi-step frequency-high, middle, low, Multi-step acceleration/ deceleration-high, middle, low, DC braking at stop, 2nd motor select, Frequency up/down, 3-wire operation, Change into normal operation during PID operation, Change into main body operation during option operation, Analog command frequency fixing, Acceleration/deceleration stop etc. Selectable
	Analog Input	V1: -10~10V, selectable V2: 0~10V/I2 4~20mA
	Pulse Train	0~32kHz, Low level: 0~2.5V, High level: 3.5~12V
Output	Open Collector Terminal	less than DC 24V 50mA
	Multi-function Relay	Fault output and drive operation status output (N.O., N.C.) less than AC 250V 1A, less than DC 30V 1A
	Analog Output	Selectable 0~12Vdc/0~24mA Frequency, Output current, Output voltage, DC stage voltage etc. selectable
	Pulse Train	Maximum 32kHz, 10~12 [V]

Protective Function

Trip	Over current trip, External signal trip, ARM short circuit current trip, Over heat trip, Input imaging trip, Ground trip, Motor over heat trip, I/O board link trip, No motor trip, Parameter writing trip, Emergency stop trip, Command loss trip, External memory error, CPU watchdog trip, Motor normal load trip, Over voltage trip, Temperature sensor trip, Drive over heat, Option trip, Output imaging trip, Fan trip, Pre-PID operation failure, External brake trip, Low voltage trip during operation, Low voltage trip, Safety A(B) trip, Analog input error, Motor overload trip,
Alarm	Command loss trip alarm, overload alarm, normal load alarm, drive overload alarm, fan operation alarm, resistance braking rate alarm, number of corrections on rotor tuning error
Momentary Power Loss	HD below 15ms (ND below 8ms): Continuous operation (To be within rated input voltage, rated output) HD above 15ms (ND above 8ms): Automatic restart operation enable

Environment

Cooling Type	Forced fan cooling structure Forced cooling type: 0.4~15 kW 200V/0.4~75 kW 400V (excluding some models)
Protection Degree	IP20/UL Open (Default), UL Enclosed type 1 (Option), IP66/NEMA 4X (Option)
Ambient Temperature	Ambient temperature under the condition of no ice or frost. HD: -10~50°C(14~122°F) / ND: -10~40°C(14~104°F) [However, recommended to use load below 80% when using at 50°C under light load]
Storage Temperature	-20~65°C(-4~149°F)
Humidity	Relative humidity below 95% RH (no dew formation)
Altitude, Vibration	Below 1,000m (From 1000 to 4000m, the rated input voltage and rated output current of the drive must be derated by 1% for every 100m.), below 9.8m/sec ² (1G)
Surrounding Environment	Environment Level: 3C3(IEC60721-3-3) classifications (for SO2, H2S, CL, NO2) Indoors, prevent contact with direct sunlight and corrosive gases
Pressure	70~106 kPa

Control Terminal Specifications

0.4~22kW

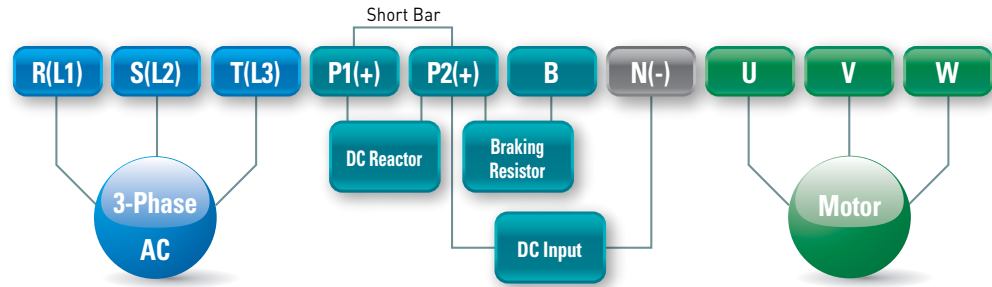

※ SHORT BAR SHOULD BE REMOVED WHEN WIRING DC REACTOR.

※ 1-PHASE 200V 0.4kW, 3-PHASE 200/400V 0.4~0.75kW : SHORT BAR OR DC REACTOR SHOULD BE CONNECTED.

30~75kW

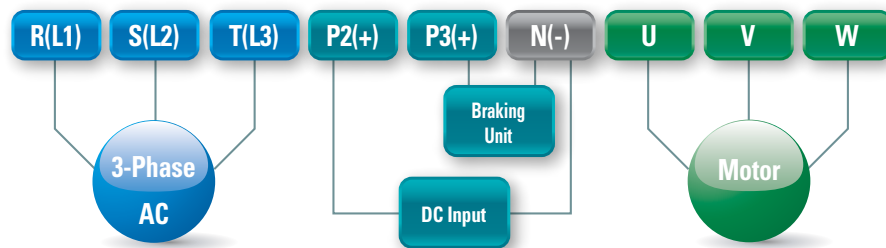

Drive Model		Screw	Torque ¹⁾ Kgf • cm	Wire ²⁾					
				mm ²		AWG			
				R.S.T	U.V.W	R.S.T	U.V.W		
200V 1-Phase	0.4 kW	M3.5	8.2~10.2 / 0.8~1.0	2	2	14	14		
	0.75 kW			2	2	14	14		
	1.5 kW			2	2	14	14		
	2.2kW	M4	12.2~14.3 / 1.2~1.4	3.5	3.5	12	12		
200V 3-Phase	0.4 kW	M3.5	8.2~10.2 / 0.8~1.0	2	2	14	14		
	0.75 kW			2	2	14	14		
	1.5 kW			2	2	14	14		
	2.2 kW			2	2	14	14		
	3.7 kW	M4	12.2~14.3 / 1.2~1.4	3.5	3.5	12	12		
	4 kW			3.5	3.5	12	12		
	5.5 kW			6	6	10	10		
	7.5 kW			6	6	10	10		
	11 kW			M5	20.4~24.5 / 2.0~2.4	10	10	8	8
15 kW	16	16	6			6			
400V 3-Phase	0.4 kW	M3.5	8.2~10.2 / 0.8~1.0	2	2	14	14		
	0.75 kW			2	2	14	14		
	1.5 kW			2	2	14	14		
	2.2 kW			2	2	14	14		
	3.7 kW	M4	12.2~14.3 / 1.2~1.4	2	2	14	14		
	4 kW			2	2	14	14		
	5.5 kW			2.5	2.5	14	14		
	7.5 kW			4	4	12	12		
	11 kW	M5	20.4~24.5 / 2.0~2.4	4	4	12	12		
	15 kW			6	6	10	10		
	18.5 kW			10	10	8	8		
	22 kW			10	10	8	8		
	30~37 kW			M8	56.1~67.3 / 5.5~6.6	25	25	4	4
	45~75 kW					70	70	1/0	1/0

¹⁾ Only use the specified torque on the screw heads otherwise damage could occur. Loose screws can cause overheating and damage.

²⁾ Use copper wires with 600V, 75°C specification.

0.4~22kW

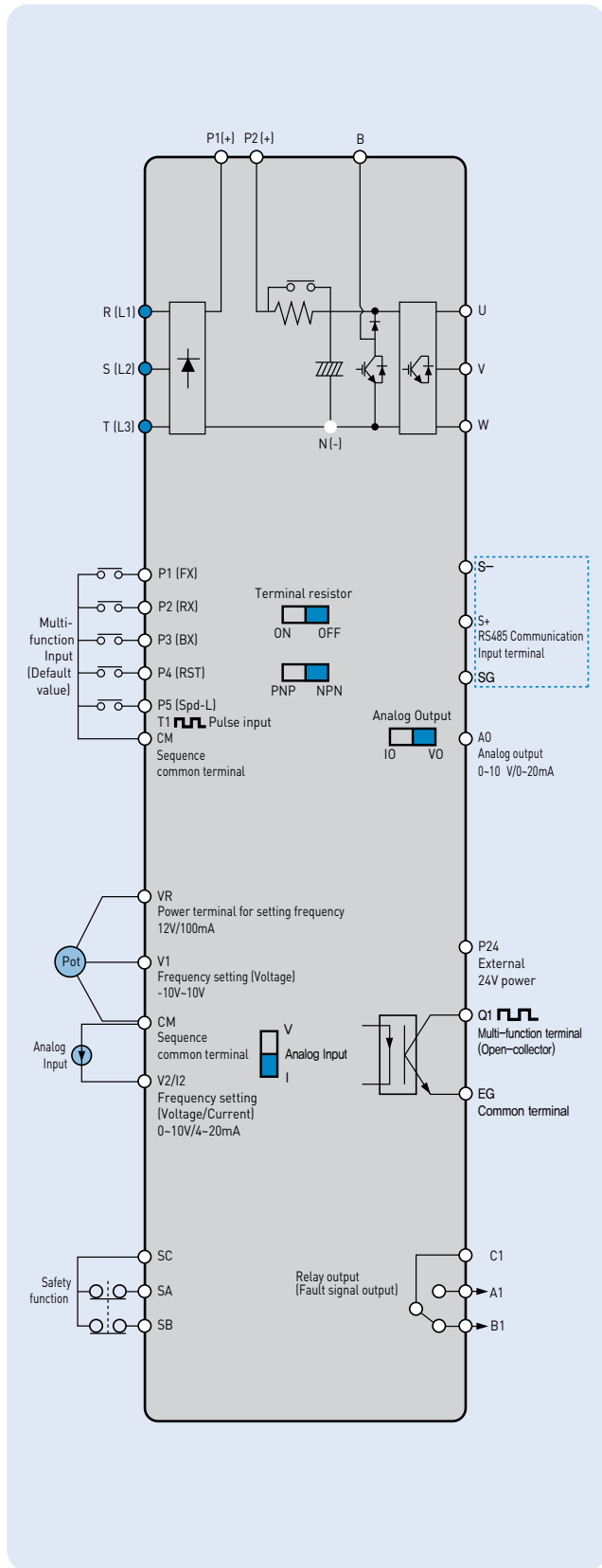

30~75kW

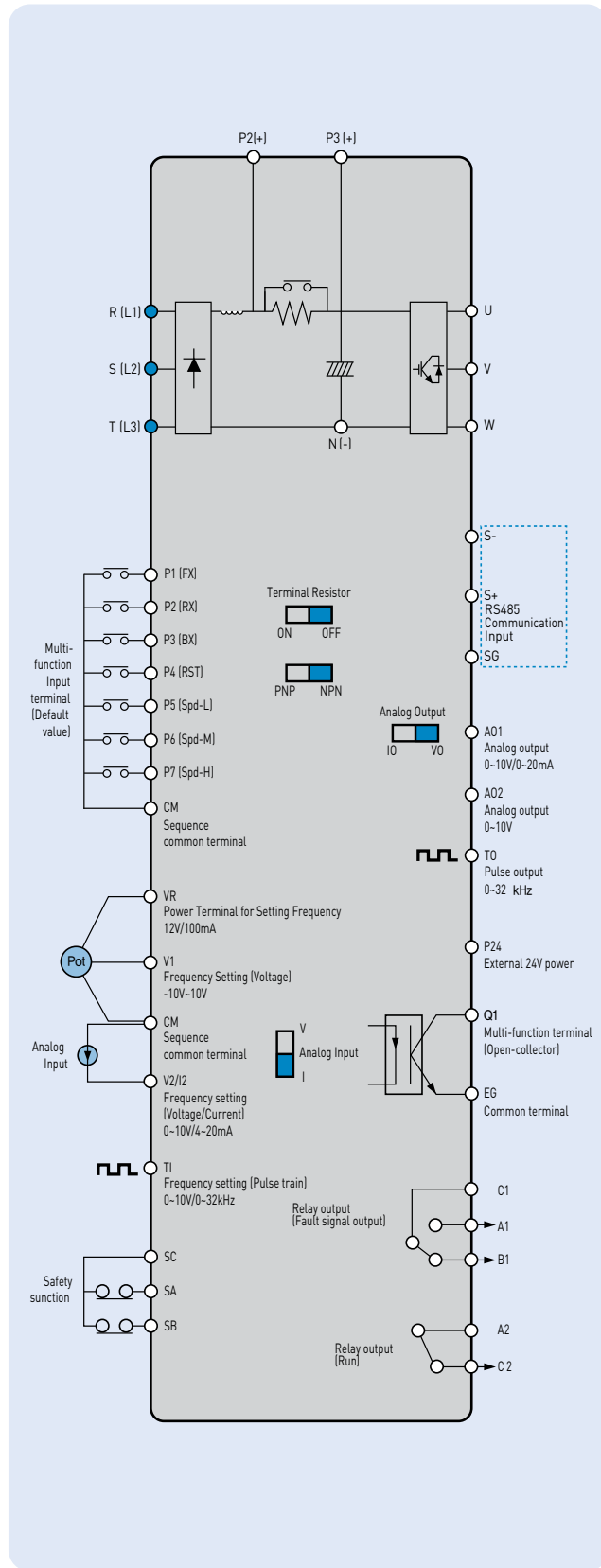

※ Default is marked in blue.

0.4~22kW

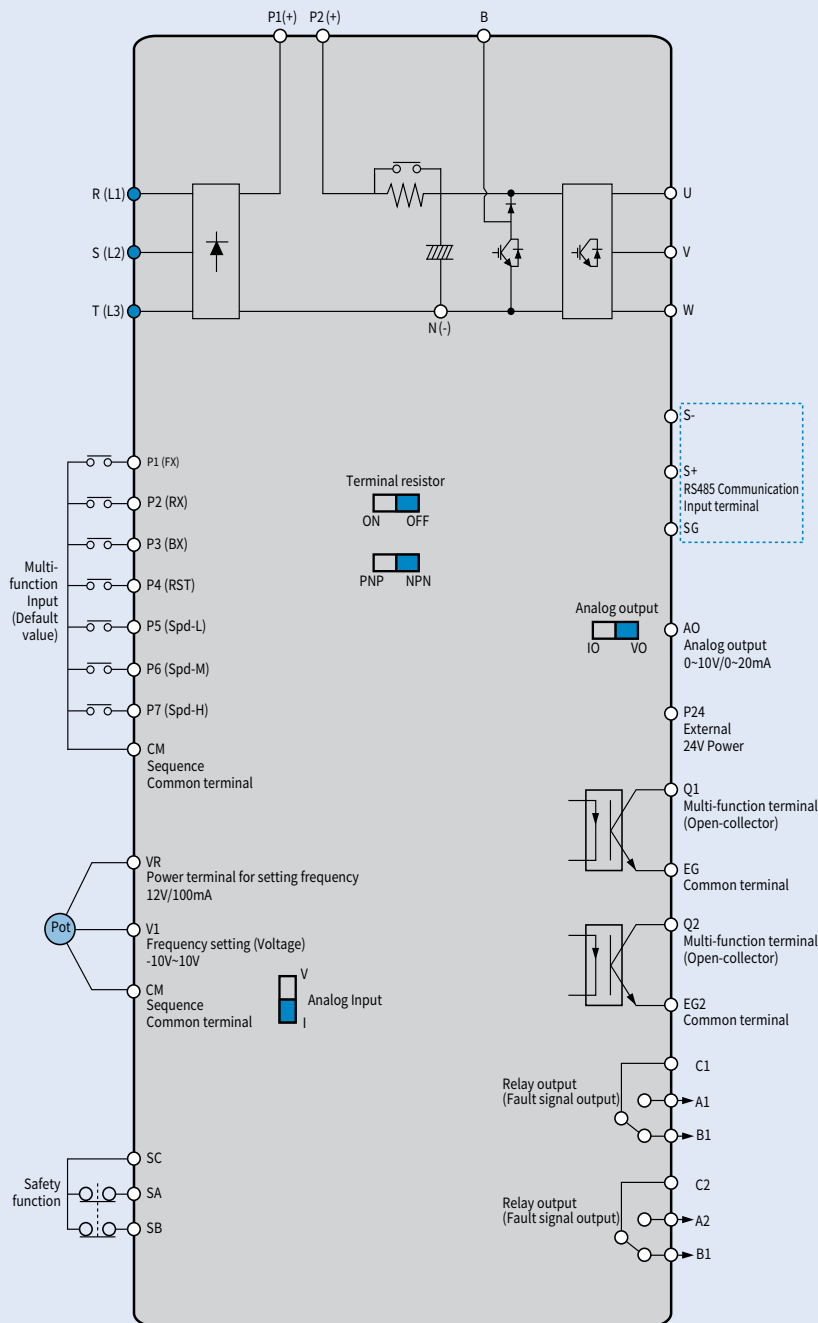

※ Default is marked in blue.

Standard I/O

0.4~22kW



Multiple I/O

0.4~22kW



※ LSLV-S100 can be supplied with either standard I/O or multiple I/O

Standard I/O

30~75kW



※ I/O board is supplied built in. IS7 LCD loader can be mounted on the front of the drive. ※ NC: Terminal not in use.

Terminal Type	Recommended Wire Size [mm ²] (AWG)		Screw	Torque	Electrical Specifications
	No Crimp-Style Terminal	Crimp-Style Terminal		N.m	
P1~P7, CM	0.75 (18)	0.5 (20)	M2	0.22 ~ 0.25	Max output V/I: 12V, 100mA, volume resistor 1~5kΩ
VR					UNIPOLAR: 0 ~ 10V (max12V)
V1					BIPOLEAR: -10 ~ 10V(max ±12V)
I2					4~20mA(max 0~24mA, input resistor 249Ω.
A01					0 ~ 10V(max output V/I: 12V, 10mA)
A02					0 ~ 20mA(Load resistor less than 500 Ω, max output current: 24mA)
Q1					0 ~ 10V(max output V/I: 12V, 10mA)
EG					Less than DC24V, 50mA
24					Max output current: 150mA
TI					0 ~ 32kHz (Low Level: 0 ~ 0.8V, High Level: 3.5 ~ 12V)
TO					0 ~ 32kHz, 0 ~ 12V
SA, SB, SC					Less than DC24V, 25mA
S+, S-, SG					
A1,B1,C1					1.0(17)
A2, C2	Less than AC250V, 5A, less than DC30V, 5A				

1) The wire length of the safety input should not exceed 30m.

2) Standard I/O is only provided for P5.

3) In case of Standard I/O, Pulse input TI and multi-function terminal P5 share the same terminal. Set the In.69 P5 define to 54(TI).

4) In case of Standard I/O, Pulse output TO and multi-function output Q1 share the same terminal. Set the OU.33Q1 define to 38(TO).

Keypad Functions



Learning how to operate a S100
(Smart device with android)

Display	Term	Function Description
	RUN Key	Run command
	STOP/RESET Key	STOP: Stop command during operation, RESET: Reset command when a fault occurs.
	UP Key	Used to scroll through codes or to increase a parameter value
	DOWN Key	Used to scroll through codes or to decrease a parameter value
	Left Key	Used to jump to other parameter groups or move the cursor to the left
	Right Key	Used to jump to other parameter groups or move the cursor to the right
	Enter Key	Used to set a parameter value or to save the changed parameter value
	Escape Key	Used to cancel the Jog or Remote/Local change key or when editing
FWD	Forward Run	Illuminated during forward run
REV	Reverse Run	Illuminated during reverse run
RUN	RUN Key	Illuminated during operation (Flickering during acceleration/Deceleration)
SET	Setting	Illuminated during parameter setting/Flickering when the ESC key is operating as a multi-key
7-Segment	Current Value	Indicates operating conditions and parameter data

Flickering when a fault occurs

Moving to Other Groups

Group Name	Display	Function Description
Operation Group ¹⁾	-	The most basic parameters required for operation such as a target frequency, acceleration/ deceleration time.
Drive Group (Drive)	<i>dr</i>	Basic operation parameters and parameters related to keypad operation, such as jog operation, motor capacity selection, torque boost.
Basic Function Group (Basic)	<i>bA</i>	This group contains basic functions such as motor parameters and multi-step frequencies.
Advanced Function Group (Advanced)	<i>Ad</i>	This group contains acceleration/deceleration patterns and frequency limit functions etc.
Control Function Group (Control)	<i>Cn</i>	This group contains functions related to sensorless and vector control.
Input Terminal Block Function Group (Input Terminal)	<i>In</i>	This group contains functions related to the drive input terminal block such as multi-function digital input and analog input.
Output Terminal Block Function Group (Output Terminal)	<i>OU</i>	This group contains functions related to the drive output terminal block such as relay and analog output.
Communication Function Group (Communication)	<i>Ci</i>	This group contains RS485 communication setting parameters.
Application Function Group (Application)	<i>AP</i>	This group contains functions for the PID control sequence operation etc.
Protective Function Group (Protection)	<i>Pr</i>	This group contains protective functions for motors and drive.
Motor Function ²⁾ (Motor 2)	<i>M2</i>	This group contains parameter settings for a second motor to be connected.

1) Indicates only the target frequency when LCD keypad is installed

2) Visible only when setting the function item of In.65-71 multi-function input terminal as no.26[2nd motor].

How to Move Between Groups in the First Code of Each Group

Group Name	Display	Group Movement
Operation Group ¹⁾	-	
Drive Group (Drive)	dr	
Basic Function Group (Basic)	bA	
Advanced Function Group (Advanced)	Ad	
Control Function Group (Control)	Cn	
Input Terminal Block Function Group (Input Terminal)	In	
Output Terminal Block Function Group (Output Terminal)	Ov	
Communication Function Group (Communication)	Co	
Application Function Group (Application)	Ap	
Protective Function Group (Protection)	Pr	
Motor Function ²⁾ (Motor 2)	112	

1) Indicates only the target frequency when LCD keypad is installed. The first code of the operation group is a place to set a target frequency. It had been set as 0.00 when shipping from the factory, however, if a user changes the operating frequency, it indicates the changed operating frequency.

2) Visible only when setting the function item of In.65~71 multi-function input terminal as no.26[2nd motor].

Protective Functions for Output Current and Input Voltage









Display	LCD Indication	Type	Description
	Over Load	Latch	Displayed when motor overload protection is selected and the load exceeds the set value. It works only if Pr.20 is set as a value other than 0.
	Under Load	Latch	Displayed when the under-load protection function is selected and the motor load is below the set normal duty level. It works only if Pr.27 is set as a value other than 0.
	Over Current1	Latch	Displayed when the drive output current rises above 200% of rated current.
	Over Voltage	Latch	Displayed when the voltage of the DC circuit increases above the specified value.
	Low Voltage	Level	Displayed when the voltage of the DC circuit decreases below the specified value.
	Low Voltage2	Latch	Displayed when the voltage of the DC circuit decreases below the specified value when operating the drive.
	Ground Trip*	Latch	Displayed when current is flowing above the specified value because of a ground fault at the drive output stage. The ground fault detection current is different for each drive capacity.
	E-Thermal	Latch	Prevents overheating when operating a motor in overload for an extended time period and operates according to inverse time characteristics. It works only if Pr.40 is set as a value other than 0.
	Out Phase Open	Latch	Displayed when any output phase to the 3-phase motor is open circuit. It works only if bit 1 of Pr.05 is set as 1.
	In Phase Open	Latch	Displayed when any output phase to the 3-phase motor is open circuit. It works only if bit 2 of Pr.05 is set as 1.
	Drive OLT	Latch	Inverse time thermal property protection function for protecting the drive from overheating. The criteria is 150%, 1 minute, 200%, 4 seconds based on the drive rated current. The 200%, 4 seconds is different for each drive capacity.
	No Motor Trip	Latch	Displayed when a motor is not connected when operating the drive. It works only if Pr.31 is set as 1.

* S100 drives rated for 4.0kW or less do not support the ground fault trip (GFT) feature. Therefore, an over current trip (OCT) or over voltage trip (OVT) may occur when there is a low-resistance ground fault.

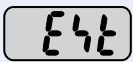
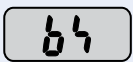

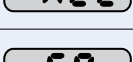
Protective Functions by the Keypad and Option

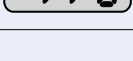





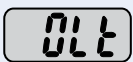

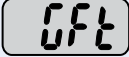

Display	LCD Indication	Type	Description
	Lost Command	Level	This fault is displayed if the frequency or operation command signal is lost when using any methods other than keypad commands. It works if Pr.12 is set as a value other than 0.
	I/O Board Trip	Latch	Displayed when a basic I/O or external communication card is not connected with the drive or the contact condition is poor. - 'S100' is displayed when I/O is disconnected from the main CPU. - If the S100 code is displayed for more than 5 seconds ErrC occurs.
	ParaWrite Trip	Latch	Displayed when there is no communication while writing parameters due to a loader cable fault or bad connection etc.
	Option Trip-1	Latch	Displayed when there is a communication error between the drive main body and a communication option board.

Protective Functions by Internal Circuit Faults and External Signals

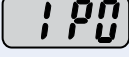
Display	LCD Indication	Type	Description
	Over Heat	Latch	A fault occurs if the temperature of the drive heat sink rises above the specified value.
	Over Current2	Latch	A fault occurs if the DC unit in the drive detects a short-circuit current value.
	External Trip	Latch	Indicates that a fault has occurred to wiring connected to a multi-function terminal that has been configured as 'External trip' (Data code 4 set in function IN 65 ~71)
	BX	Level	Indicates that a signal has been received to a multi-function terminal that has been configured as 'BX Base Block' (Data code 5 set in function IN 65 ~71)
	H/W-Diag	Fatal	There is an internal fault on the memory (EEPROM), analog-digital converter output (ADC off set), and CPU malfunction (Watch dog-1, Watch dog-2) etc. in the drive. - EEP Err: There is an internal fault when reading/writing parameters due to KPD EEP Rom damage. - ADC Off Set: There is a fault with the internal current sensing circuit.
	NTC Open	Latch	This fault occurs if an error is detected in the temperature detecting sensor of the power semiconductor (IGBT).
	Fan Trip	Latch	This fault occurs if a cooling fan error is detected. It works if Pr.79 is selected as 0.
	Pre-PID Fail	Latch	While operating Pre-PID by setting a function between AP.34~36, if the control value(PID feedback) is continuously entered below the set value, this fault is displayed.
	Ext-Brake	Latch	This error can happen when operating external brake signals and any of the multi-function input terminals have been configured accordingly. If the drive output current at starting is held at less than Ad-41 level this fault is output. Set one of OU-31, 32 as no. 35 BR Control.
	Safety A(B) Err	Latch	This error occurs if a fault with the safety inputs occur. If either input A or B is missing, the drive will display this fault code.

Fault Recovery

Display	Type	Cause	Solution
	Over Load	Load is larger than the motor rating. The value set in the overload fault level (Pr.21) is too small.	Increase the capacity of motor and drive. Increase the set value of the overload fault level
	Under Load	There is a problem in the connection between the motor and the load. The normal duty level (Pr.29, 30) is set larger than minimum load of the system.	Decrease the capacity of motor and drive. Lower the set value of the light load level.
	Over Current1	The acceleration/deceleration is too short for the inertia of load(GD2). The drive load is larger than the rating. The drive output is applied when the motor is idling. Motor mechanical brake is on.	Set the acceleration/deceleration time longer. Replace with an drive with large capacity. Operate after the motor stops or use the speed search function. Check the mechanical brake.

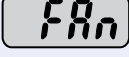
Display	Type	Cause	Solution
	Over Voltage	The deceleration time is too short compared to the inertia of load (GD2). A regenerative load is connected to the drive output. AC input voltage is high.	Set the deceleration time longer. Use a braking resistor. Check whether the AC input voltage is above the specified value.
	Low Voltage	AC input voltage is low. Larger load than the power capacity is connected to the power system. (Welding machine or motor line-start etc.) A device on the power input side of the drive is defective.	Check whether the AC input voltage is below the specified value. Increase the power capacity. Replace the electromagnetic contactor.
	Low Voltage2	AC input voltage is lowered during operation. There is an input open phase under the low AC input voltage condition. A device on the power input side of the drive is defective.	Check whether the AC input voltage is below the specified value. Check the input wiring. Replace the electromagnetic contactor.
	Ground Trip	The drive output wire has a ground fault. The motor insulation has failed.	Investigate the drive output terminal wiring. Replace the motor.
	E-Thermal	The motor is overheated. The drive load is larger than the rating. Electronic thermal level is set low. The drive has been operating at low speed for a long time.	Reduce the load or the operating frequency. Increase the drive capacity. Set the appropriate electronic thermal level. Force cool the motor.
	Out Phase Open	Bad connection or open circuit at an output device. Output wiring & defect occurred.	Check for faulty/open device on the drive output device. Check the output wiring.
	In Phase Open	Bad connection on a device on the drive input side. Input wiring defect occurred. Consider replacing the drive DC unit condenser.	Check the device at the drive input side. Check the input wiring. Replace the drive DC unit condenser. Contact the nearest service center.
	Drive OLT	Load is larger than the drive rating. The torque boost amount is too large.	Increase the capacity of motor and drive. Reduce the torque boost amount.
	Over Heat	There is a problem with the cooling system. The drive has been used for a longer time than the replacement period of cooling fan. Ambient temperature is high.	Check whether there is a foreign substance in the vent such as the air inlet and outlet. Replace the drive cooling fan. Keep the temperature around the drive below 50°C.
	Over Current2	The drive output wiring is short-circuited. There is a problem in the drive power semiconductor (IGBT).	Investigate the drive output terminal wiring. The drive cannot be operated. Contact the nearest service center.
	NTC Open	Ambient temperature is too low. There is a problem in the temperature sensor inside the drive.	Operate the drive at a place where ambient temperature is above -10°C. Contact the nearest service center.
	FAN Lock	Foreign substances have entered into the drive vent where the fan is located. Consider replacing the drive cooling fan.	Check the air inlet and outlet. Replace the drive cooling fan.
	IP66 FAN Trip	The fan connector is not connected. Consider replacing the drive cooling fan.	Connect the fan connector. Replace the drive cooling fan.

An Example of Changing the Acceleration Time From 5.0 Second to 16.0 Second

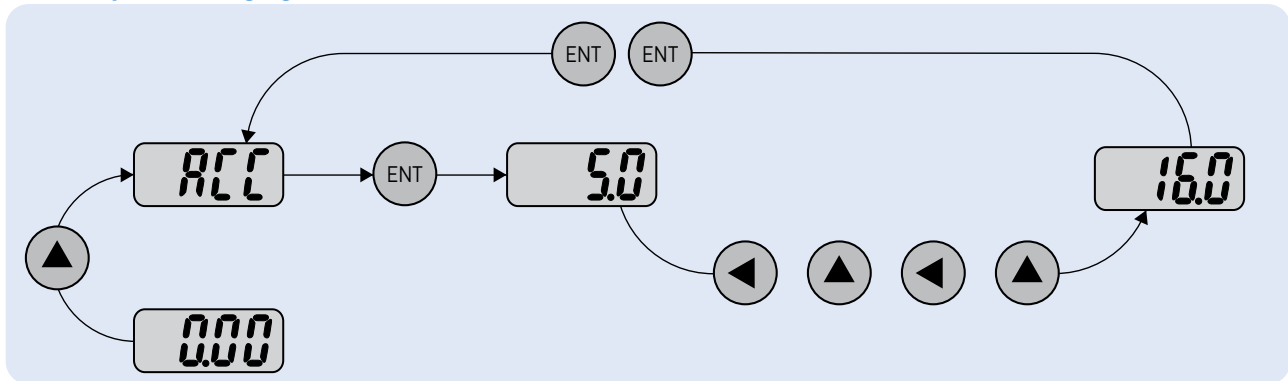

1		<ul style="list-style-type: none"> Indicate the first code information of the operation group. Press the UP key (▲)
2		<ul style="list-style-type: none"> Indicate the acceleration time ACC that is the second code of the operation group. Press the ENTER key (ENT).
3		<ul style="list-style-type: none"> 0 in 5.0 flickers at 1-second interval. Press the Left Shift key (◀)
4		<ul style="list-style-type: none"> 5 in 5.0 flickers, which indicates that the value of 5 can be changed. Press the UP key (▲)
5		<ul style="list-style-type: none"> The value is changed into 6.0. Press the left shift key (◀)
6		<ul style="list-style-type: none"> As 0 in 06.0 flickers, it indicates 06.0. Press the UP key (▲)
7		<ul style="list-style-type: none"> 16.0 is indicated. Press the ENTER key (ENT). 16.0 flickers. Press the ENTER key (ENT).
8		<ul style="list-style-type: none"> ACC is indicated. The acceleration time is changed into 16.0 second.

1) Flickering when modifying a parameter is for asking whether you are going to enter the value. When pressing the enter key (ENT) at this step, the input is completed. If you do not want to enter the modified value, you can press the left, right, up or down keys (◀) (▶) (▲) (▼) except the enter key (ENT) in the ON condition to cancel the input.

How to Move Between Codes in the Operation Group

	1		<ul style="list-style-type: none"> Indicates 0.00 that is the first code of the operation group. Press the UP key (▲)
	2		<ul style="list-style-type: none"> Indicates ACC that is the second code of the operation group. Press the UP key (▲)
	3		<ul style="list-style-type: none"> Indicates dEC that is the third code of the operation group. Press the UP key (▲)
	4		<ul style="list-style-type: none"> Indicates drC that is the last code of the operation group. Press the UP key (▲) once again on the last code of the operation group.
	5		<ul style="list-style-type: none"> Return to the first code of the operation group.
<ul style="list-style-type: none"> Using the DOWN key (▼), you can move in the opposite order of the above. 			

Braking Resistor Specification

Motor Rating [kW]	200V 1-Phase		200V 3-Phase		400V 3-Phase	
	Resistor [ohm]	Watt [W]	Resistor [ohm]	Watt [W]	Resistor [ohm]	Watt [W]
0.4kW	300	100	300	100	1,200	100
0.75kW	150	150	150	150	600	150
1.5kW	60	300	60	300	300	300
2.2kW	50	400	50	400	200	400
3.7kW	-	-	33	600	130	600
4.0kW	-	-	33	600	130	600
5.5kW	-	-	20	800	85	1,000
7.5kW	-	-	15	1,200	60	1,200
11kW	-	-	10	2,400	40	2,000
15kW	-	-	8	2,400	30	2,400
18.5kW	-	-	-	-	20	3,600
22kW	-	-	-	-	20	3,600

※ The standard for braking torque is 150% and the working rate (%ED) is 5%. If the working rate is 10%, the rated capacity for braking resistance must be calculated at twice the standard.

Motor Rating [kW]	200V 1-Phase		200V 3-Phase		400V 3-Phase	
	Resistor [ohm]	Watt [W]	Resistor [ohm]	Watt [W]	Resistor [ohm]	Watt [W]
30kW	-	-	-	-	16.9	6,400
37kW	-	-	-	-	16.9	6,400
45kW	-	-	-	-	11.4	9,600
55kW	-	-	-	-	11.4	9,600
75kW	-	-	-	-	8.4	12,800

※ Reference: 100% braking torque, 10%ED

- The resistance/rated capacity/braking torque/%ED of DB Resistor are valid only for the DB unit of type A and the values of DB Resistor for type B and C refer to the manual of DB Unit..
- Rating Watt of DBU has to be doubled when %ED is doubled.

Compatible Circuit Break, Leakage Break and Magnetic Contactor Models

Voltage	Capacity [kW]	Circuit Break (MCCB)				Leakage Break (ELCB)		Magnetic Contactor (MC)		
		Model	Rated Current[A]	Model	Rated Current[A]	Model	Rated Current[A]	Model	Rated Current[A]	
1-Phase 200V	0.4	ABS33c	5	UTE100	15	EBS33c	5	MC-6a	9	
	0.75		10		15		10	MC-9a, MC-9b	11	
	1.5		15		15		15	MC-18a, MC-18b	18	
	2.2		20		20		20	MC-22b	22	
3-Phase 200V	0.4	ABS33c	5	UTE100	15	EBS33c	5	MC-6a	9	
	0.75		10		15		10	MC-9a, MC-9b	11	
	1.5		15		15		15	MC-18a, MC-18b	18	
	2.2		20		20		20	MC-22b	22	
	3.7		30		30		30	MC-32a	32	
	4.0		30		30		30	MC-32a	32	
	5.5	ABS53c	50	UTS150	50	EBS53c	50	MC-50a	55	
	7.5	ABS63c	60		60	EBS63c	60	MC-65a	65	
	11	ABS103c	100		90	EBS103c	100	MC-85a	85	
	15		125		125		125	MC-130a	130	
3-Phase 400V	0.4	ABS33c	3	UTE100	15	EBS33c	5	MC-6a	7	
	0.75		5		15		5	MC-6a	7	
	1.5		10		15		10	MC-9a, MC-9b	9	
	2.2		10		15		10	MC-12a, MC-12b	12	
	3.7		15		15		15	MC-18a, MC-18b	18	
	4.0		20		20		20	MC-18a, MC-18b	18	
	5.5		30		30		30	MC-22b	22	
	7.5		30		30		30	MC-32a	32	
	11	ABS53c	50	UTS150	50	EBS53c	50	MC-50a	50	
	15	ABS63c	60		60	EBS63c	60	MC-65a	65	
	18.5	ABS103c	75		80	EBS103c	75	MC-75a	75	
			100		90		100	MC-85a	85	
	30	ABS103c	125		125	EBS103c	125	MC-100a	105	
	37	ABS203c	150		UTS250	150	EBS203c	150	MC-130a	130
	45		175			175		175	MC-150a	150
55	225		225	225		MC-185a		185		
75	ABS403c	300	UTS400	300	EBS403c	300	MC-225a	225		

Fuse and Reactor Specifications

Product [kW]		AC Input Fuse		AC Reactor		DC Reactor						
		Current [A]	Voltage [V]	Inductance [mH]	Current [A]	Inductance [mH]	Current [A]					
Single Phase 200V	0.4	10	600	1.20	10	4	8.67					
	0.75											
	1.5							15	0.88	14	3	13.05
	2.2							20	0.56	20	1.3	18.45
3-Phase 200V	0.4	10		1.20	10	4	8.67					
	0.75											
	1.5							15	0.88	14	3	13.05
	2.2							20	0.56	20	1.33	18.45
	3.7	32		0.39	30	1.33	26.35					
	4.0	50										
	5.5	50		0.30	34	1.60	32					
	7.5	63		0.22	45	1.25	43					
	11	80		0.16	64	0.95	61					
	15	100		0.13	79	0.70	75					
3-Phase 400V	0.4	10		600	4.81	4.8	16	4.27				
	0.75											
	1.5		15						3.23	7.5	12	6.41
	2.2		20						2.34	10	8	8.9
	3.7	32	1.22		15	5.4	13.2					
	4.0	50										
	5.5	32	1.12		19	3.20	17					
	7.5	35	0.78		27	2.50	25					
	11	50	0.59		35	1.90	32					
	15	63	0.46		44	1.40	41					
	18.5	70	0.40		52	1.00	49					
	22	100	0.30		68	0.70	64					
	30	125	0.29		69	-	-					
	37		0.24		85	-	-					
	45		0.20		100	-	-					
	55	200	0.15		134	-	-					
75	0.13		160	-	-							

※ Only use Class H or RK5, UL listed input fuses and UL listed circuit brake. See the table above for the voltage and current ratings for fuses and circuit brake.

Dynamic Braking Unit(DBU)

UL Form	Capacity of Applied Motor	Braking Unit	Terminal Arrangement & Dimensions
UL Type (A Type)	30~37kW	SV370DBU-4U	Refer to group 1.
	45~55kW	SV550DBU-4U	
	75kW	SV750DBU-4U	
Non UL Type (B Type)	30~37kW	SV037DBH-4	Refer to group 2.
	45~75kW	SV075DBH-4	Refer to group 3.
		SV075DB-4	
Non UL Type (C Type)	30~37kW	LSLV0370DBU-4HN	Refer to group 4.
		LSLV0370DBU-4LN	Refer to group 5.
	45~75kW	LSLV0750DBU-4LN	

※ Please refer to the manual for dimensions of DB Unit.

- It is not necessary to use option type dynamic braking unit for S100 below 22kW capacity because basically the dynamic braking unit is built in.
- You must refer to dynamic braking unit manual for usage recommended dynamic braking unit in the table above due to changeable table.

Terminal Arrangement

Group 1

P	N	G	B1	B2
---	---	---	----	----

Terminals	Functions
G	Ground terminal
B2	Terminal for connection with B2 of DBU
B1	Terminal for connection with B1 of DBU

Group 2:

G	N	B2	P/B1
---	---	----	------

Terminals	Functions
N	Terminal for connection with N of drive
P	Terminal for connection with P1 of drive

Group 3

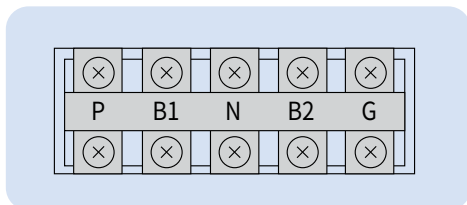

Terminals	Functions
G	Ground terminal
B2	Terminal for connection with B2 of DBU
B1	Terminal for connection with B1 of DBU
N	Terminal for connection with N of drive
P	Terminal for connection with P1 of drive

Group 4, 5

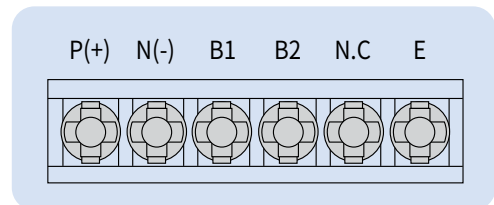

Terminals	Functions
P(+)	Terminal for connection with P of drive
N(-)	Terminal for connection with N of drive
B1	Terminal for connection with B1 of DBU
B2	Terminal for connection with B2 of DBU
N.C	Unused
E	Ground terminal

※ You must refer to dynamic braking unit manual for braking resistor to use dynamic braking unit.

LSLV0004S100-2 / 0004S100-4

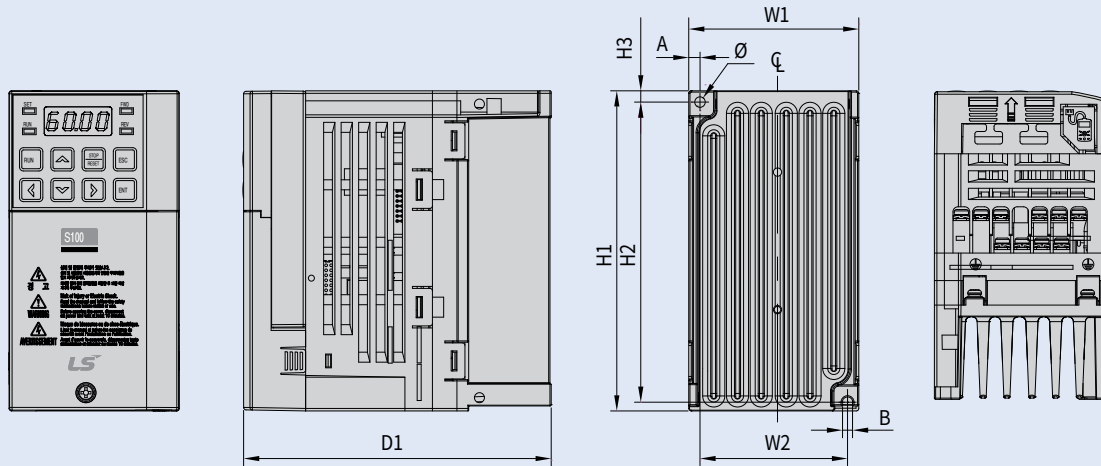

Unit : mm(Inches), kg

Drive Capacity	W1	W2	H1	H2	H3	D1	A	B	Ø	Weight
LSLV0004S100-2	68 (2.68)	61.1 (2.41)	128 (5.04)	119 (4.69)	5 (0.20)	123 (4.84)	3.5 (0.14)	4 (0.16)	4 (0.16)	0.86
LSLV0004S100-4	68 (2.68)	61.1 (2.41)	128 (5.04)	119 (4.69)	5 (0.20)	123 (4.84)	3.5 (0.14)	4 (0.16)	4 (0.16)	0.86

LSLV0004S100-1 / 0008S100-2 / 0008S100-4

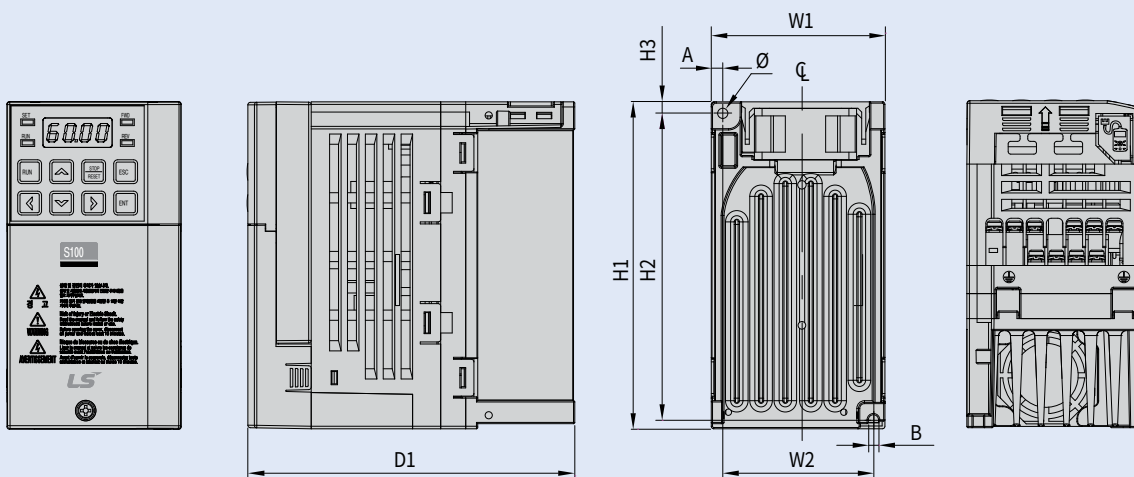

Unit : mm(Inches), kg

Drive Capacity	W1	W2	H1	H2	H3	D1	A	B	Ø	Weight
LSLV0004S100-1	68 (2.68)	61.1 (2.41)	128 (5.04)	119 (4.69)	5 (0.20)	128 (5.04)	3.5 (0.14)	4 (0.16)	4 (0.16)	0.88
LSLV0008S100-2	68 (2.68)	61.1 (2.41)	128 (5.04)	119 (4.69)	5 (0.20)	128 (5.04)	3.5 (0.14)	4 (0.16)	4 (0.16)	0.86
LSLV0008S100-4	68 (2.68)	61.1 (2.41)	128 (5.04)	119 (4.69)	5 (0.20)	128 (5.04)	3.5 (0.14)	4 (0.16)	4 (0.16)	0.88

LSLV0008S100-1 / 0015S100-2 / 0015S100-4

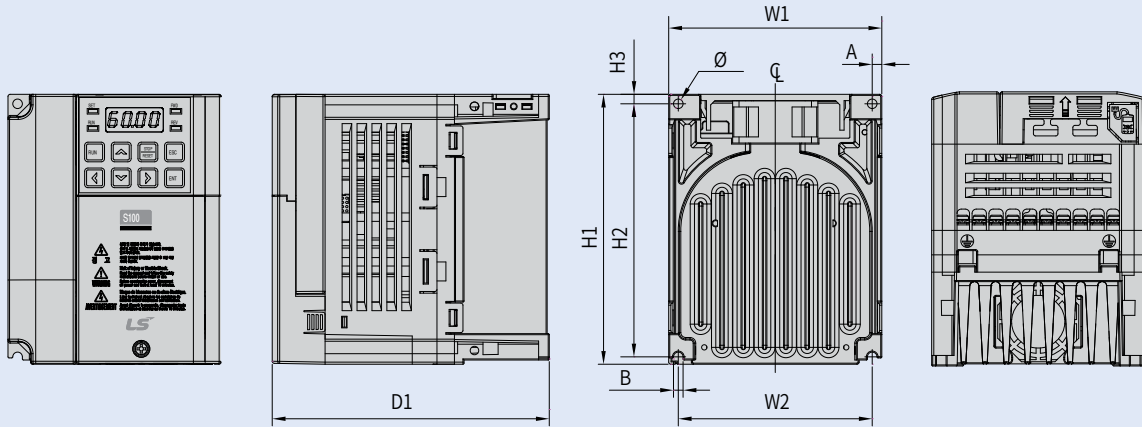

Unit : mm(Inches), kg

Drive Capacity	W1	W2	H1	H2	H3	D1	A	B	Ø	Weight
LSLV0008S100-1	100 (3.94)	91 (3.58)	128 (5.04)	120 (4.72)	4.5 (0.18)	130 (5.12)	4.5 (0.18)	4.5 (0.18)	4.5 (0.18)	1.3
LSLV0015S100-2	100 (3.94)	91 (3.58)	128 (5.04)	120 (4.72)	4.5 (0.18)	130 (5.12)	4.5 (0.18)	4.5 (0.18)	4.5 (0.18)	1.5
LSLV0015S100-4	100 (3.94)	91 (3.58)	128 (5.04)	120 (4.72)	4.5 (0.18)	130 (5.12)	4.5 (0.18)	4.5 (0.18)	4.5 (0.18)	1.5

LSLV0015S100-1 / 0022S100-2 / 0022S100-4

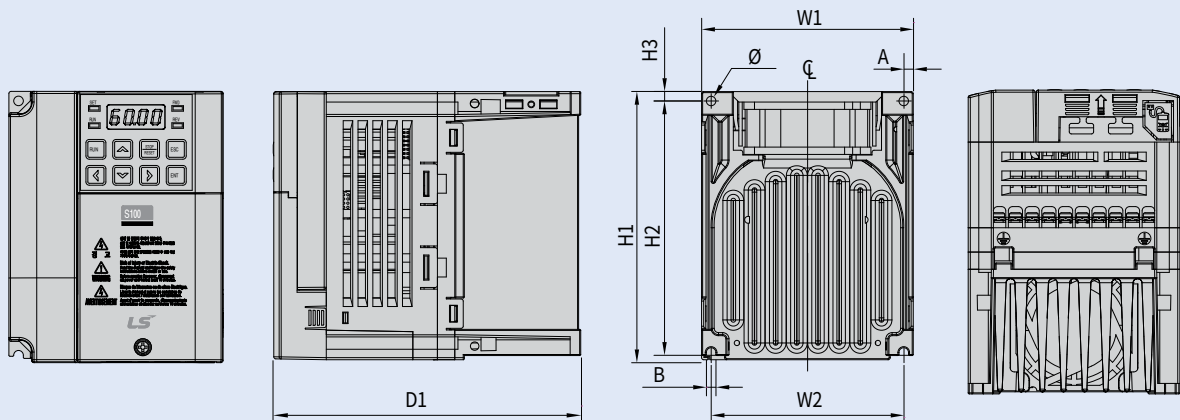

Unit : mm(Inches), kg

Drive Capacity	W1	W2	H1	H2	H3	D1	A	B	Ø	Weight
LSLV015S100-1	100 (3.94)	91 (3.58)	128 (5.04)	120 (4.72)	4.5 (0.18)	145 (5.71)	4.5 (0.18)	4.5 (0.18)	4.5 (0.18)	1.5
LSLV022S100-2	100 (3.94)	91 (3.58)	128 (5.04)	120 (4.72)	4.5 (0.18)	145 (5.71)	4.5 (0.18)	4.5 (0.18)	4.5 (0.18)	1.5
LSLV022S100-4	100 (3.94)	91 (3.58)	128 (5.04)	120 (4.72)	4.5 (0.18)	145 (5.71)	4.5 (0.18)	4.5 (0.18)	4.5 (0.18)	1.5

LSLV0022S100-1 / 0037S100-2 / 0037S100-4 / 0040S100-2 / 0040S100-4

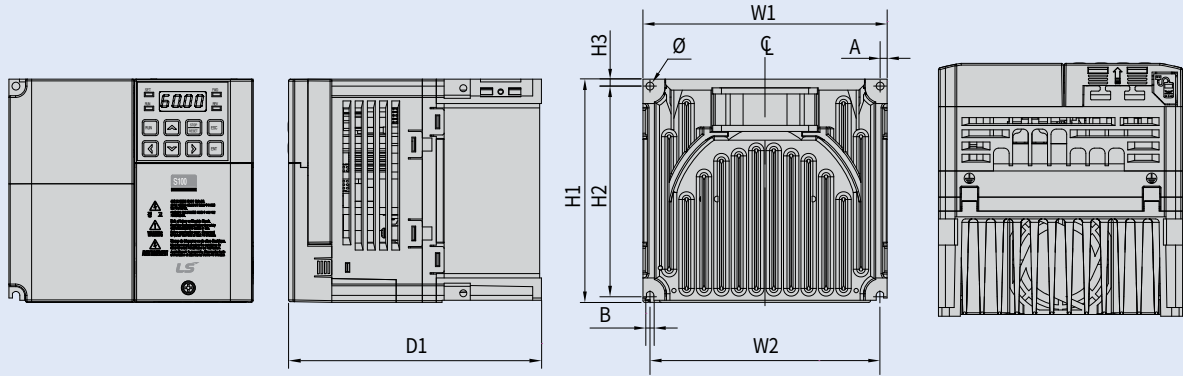

Unit : mm(Inches), kg

Drive Capacity	W1	W2	H1	H2	H3	D1	A	B	Ø	Weight
LSLV0022S100-1	140 (5.51)	132.2 (5.21)	128 (5.04)	120.7 (4.75)	3.7 (0.15)	145 (5.71)	3.9 (0.15)	4.4 (0.17)	4.5 (0.18)	2.2
LSLV0037S100-2	140 (5.51)	132.2 (5.21)	128 (5.04)	120.7 (4.75)	3.7 (0.15)	145 (5.71)	3.9 (0.15)	4.4 (0.17)	4.5 (0.18)	2.3
LSLV0037S100-4	140 (5.51)	132.2 (5.21)	128 (5.04)	120.7 (4.75)	3.7 (0.15)	145 (5.71)	3.9 (0.15)	4.4 (0.17)	4.5 (0.18)	2.7
LSLV0040S100-2	140 (5.51)	132.2 (5.21)	128 (5.04)	120.7 (4.75)	3.7 (0.15)	145 (5.71)	3.9 (0.15)	4.4 (0.17)	4.5 (0.18)	2.3
LSLV0040S100-4	140 (5.51)	132.2 (5.21)	128 (5.04)	120.7 (4.75)	3.7 (0.15)	145 (5.71)	3.9 (0.15)	4.4 (0.17)	4.5 (0.18)	2.7

LSLV0004S100-1 / 0004S100-4 / 0008S100-4 (Built-in EMC)

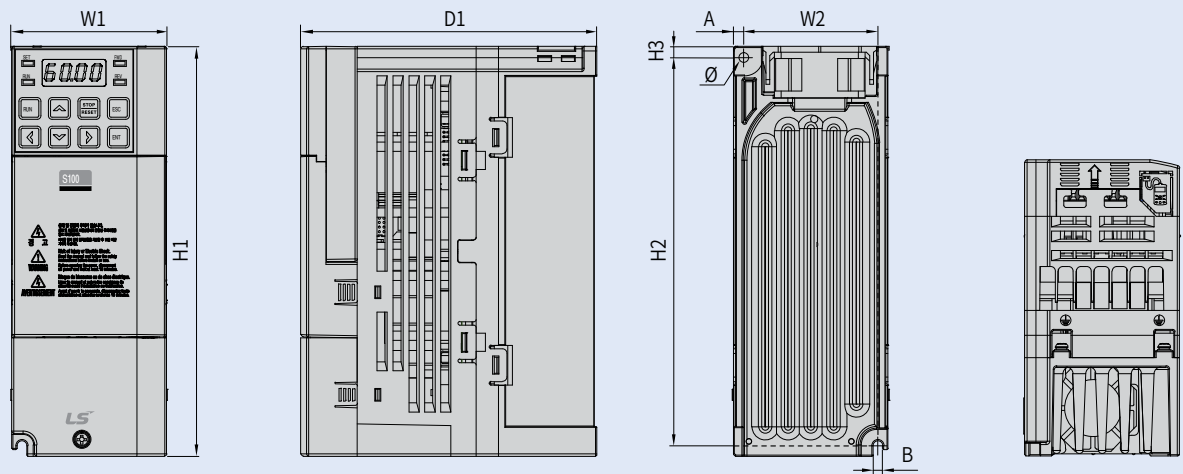

Unit : mm(Inches), kg

Drive Capacity	W1	W2	H1	H2	H3	D1	A	B	Ø	Weight
LSLV0004S100-1 ¹⁾	68 (2.68)	59 (2.3)	180 (7.09)	170.5 (6.71)	5 (0.20)	130 (5.12)	4.5 (0.18)	4 (0.16)	4 (0.16)	1.1
LSLV0004S100-4 ¹⁾	68 (2.68)	59 (2.3)	180 (7.09)	170.5 (6.71)	5 (0.20)	130 (5.12)	4.5 (0.18)	4 (0.16)	4 (0.16)	1.2
LSLV0008S100-4 ¹⁾	68 (2.68)	59 (2.3)	180 (7.09)	170.5 (6.71)	5 (0.20)	130 (5.12)	4.5 (0.18)	4 (0.16)	4 (0.16)	1.2

¹⁾ EMC filter built-in Class3

LSLV0008S100-1 / 0015S100-1 / 0015S100-4 / 0022S100-4 (Built-in EMC)

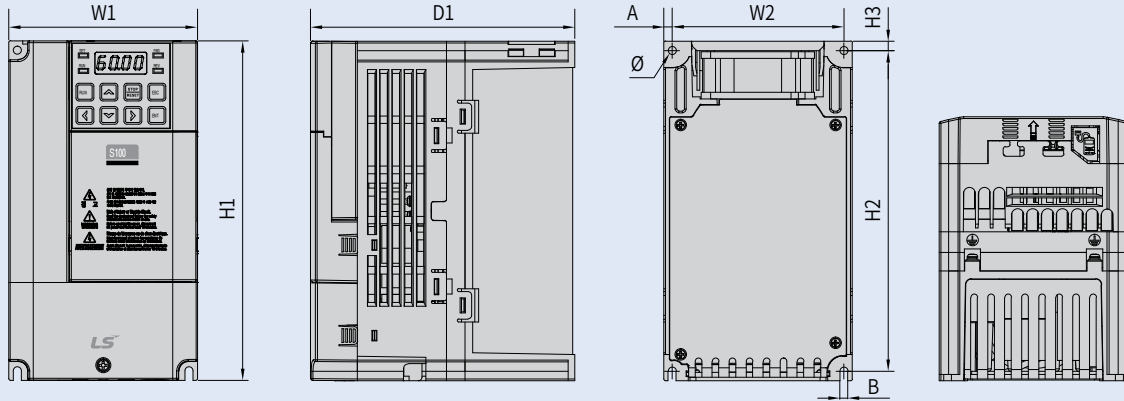

Unit : mm(Inches), kg

Drive Capacity	W1	W2	H1	H2	H3	D1	A	B	Ø	Weight
LSLV0008S100-1 ¹⁾	100 (3.94)	91 (3.59)	180 (7.09)	170 (6.69)	5 (0.20)	140 (5.51)	4.5 (0.18)	4.5 (0.18)	4.5 (0.18)	1.8
LSLV0015S100-1 ¹⁾	100 (3.94)	91 (3.59)	180 (7.09)	170 (6.69)	5 (0.20)	140 (5.51)	4.5 (0.18)	4.5 (0.18)	4.5 (0.18)	1.8
LSLV0015S100-4 ¹⁾	100 (3.94)	91 (3.59)	180 (7.09)	170 (6.69)	5 (0.20)	140 (5.51)	4.5 (0.18)	4.5 (0.18)	4.5 (0.18)	1.8
LSLV0022S100-4 ²⁾	100 (3.94)	91 (3.59)	180 (7.09)	170 (6.69)	5 (0.20)	140 (5.51)	4.5 (0.18)	4.5 (0.18)	4.5 (0.18)	1.8

1) EMC filter built-in Class2 2) EMC filter built-in Class3

LSLV0022S100-1 / 0037S100-4 / 0040S100-4 (Built-in EMC)

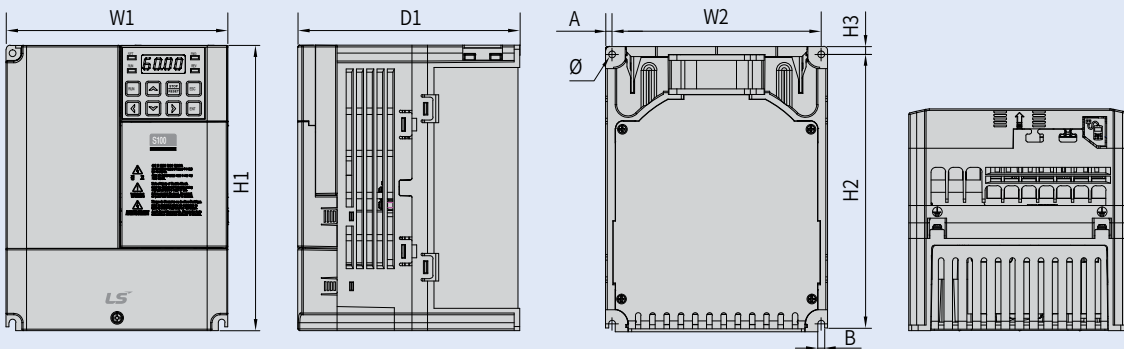

Unit : mm(Inches), kg

Drive Capacity	W1	W2	H1	H2	H3	D1	A	B	Ø	Weight
LSLV0022S100-1 ¹⁾	140 (5.51)	132 (5.20)	180 (7.09)	170 (6.69)	5 (0.20)	140 (5.51)	4 (0.16)	4.5 (0.18)	4.5 (0.18)	2.2
LSLV0037S100-4 ²⁾	140 (5.51)	132 (5.20)	180 (7.09)	170 (6.69)	5 (0.20)	140 (5.51)	4 (0.16)	4.5 (0.18)	4.5 (0.18)	2.2
LSLV0040S100-4 ²⁾	140 (5.51)	132 (5.20)	180 (7.09)	170 (6.69)	5 (0.20)	140 (5.51)	4 (0.16)	4.5 (0.18)	4.5 (0.18)	2.2

1) EMC filter built-in Class2 2) EMC filter built-in Class3

LSLV0055S100-2 / 0075S100-2 / 0055S100-4 / 0075S100-4

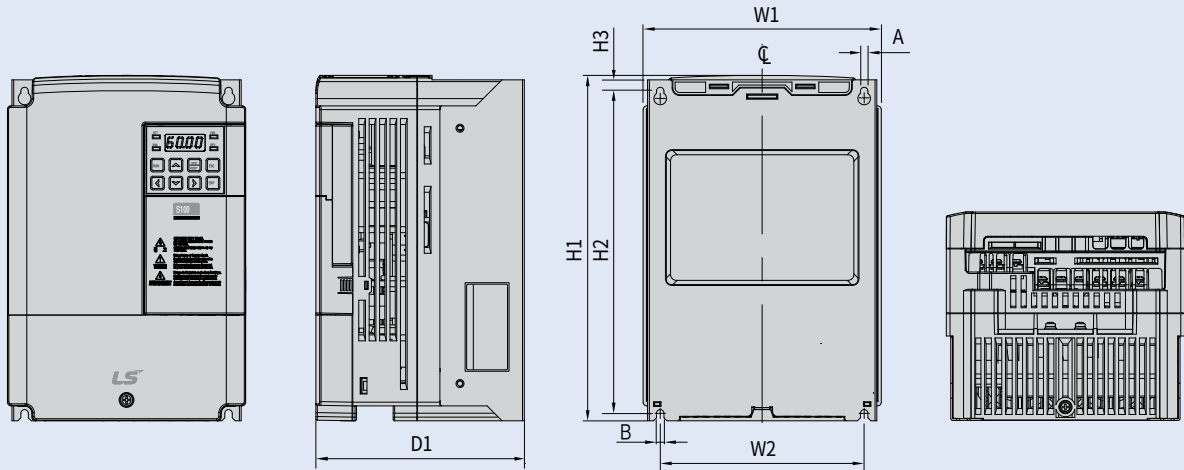

Unit : mm(Inches), kg

Drive Capacity	W1	W2	H1	H2	H3	D1	A	B	Ø	Weight
LSLV0055S100-2	160 (6.30)	137 (5.39)	232 (9.13)	216.5 (8.52)	10.5 (0.41)	140 (5.51)	5 (0.20)	5 (0.20)	-	3.3
LSLV0075S100-2	160 (6.30)	137 (5.39)	232 (9.13)	216.5 (8.52)	10.5 (0.41)	140 (5.51)	5 (0.20)	5 (0.20)	-	3.3
LSLV0055S100-4 ¹⁾	160 (6.30)	137 (5.39)	232 (9.13)	216.5 (8.52)	10.5 (0.41)	140 (5.51)	5 (0.20)	5 (0.20)	-	3.3 / 3.4
LSLV0075S100-4 ¹⁾	160 (6.30)	137 (5.39)	232 (9.13)	216.5 (8.52)	10.5 (0.41)	140 (5.51)	5 (0.20)	5 (0.20)	-	3.3 / 3.4

¹⁾ EMC filter built-in Class3

LSLV0110S100-2 / 0110S100-4 / 0150S100-4

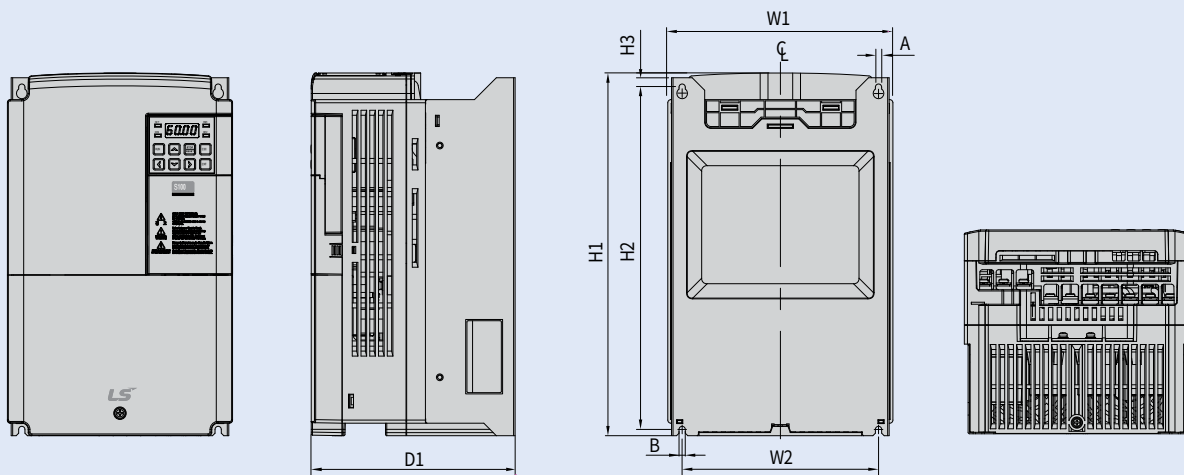

Unit : mm(Inches), kg

Drive Capacity	W1	W2	H1	H2	H3	D1	A	B	Ø	Weight
LSLV0110S100-2	180 (7.09)	157 (6.18)	290 (11.4)	273.7 (10.8)	11.3 (0.44)	163 (6.42)	5 (0.20)	5 (0.20)	-	4.6
LSLV0110S100-4 ¹⁾	180 (7.09)	157 (6.18)	290 (11.4)	273.7 (10.8)	11.3 (0.44)	163 (6.42)	5 (0.20)	5 (0.20)	-	4.6 / 4.8
LSLV0150S100-4 ¹⁾	180 (7.09)	157 (6.18)	290 (11.4)	273.7 (10.8)	11.3 (0.44)	163 (6.42)	5 (0.20)	5 (0.20)	-	4.6 / 4.8

¹⁾ EMC filter built-in Class3

LSLV0150S100-2 / 0185S100-4 / 0220S100-4

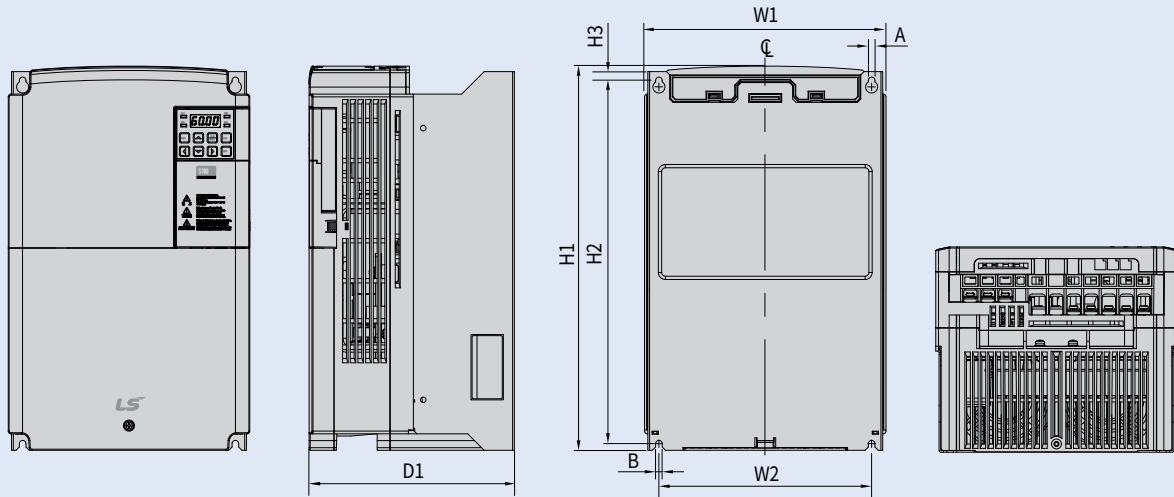

Unit : mm(Inches), kg

Drive Capacity	W1	W2	H1	H2	H3	D1	A	B	Ø	Weight
LSLV0150S100-2	220 (8.66)	193.8 (7.63)	350 (13.8)	331 (13.0)	13 (0.51)	187 (7.36)	6 (0.24)	6 (0.24)	-	4.6
LSLV0185S100-4 ¹⁾	220 (8.66)	193.8 (7.63)	350 (13.8)	331 (13.0)	13 (0.51)	187 (7.36)	6 (0.24)	6 (0.24)	-	7.5
LSLV0220S100-4 ¹⁾	220 (8.66)	193.8 (7.63)	350 (13.8)	331 (13.0)	13 (0.51)	187 (7.36)	6 (0.24)	6 (0.24)	-	7.5

¹⁾ EMC filter built-in Class3

LSLV0300S100-4

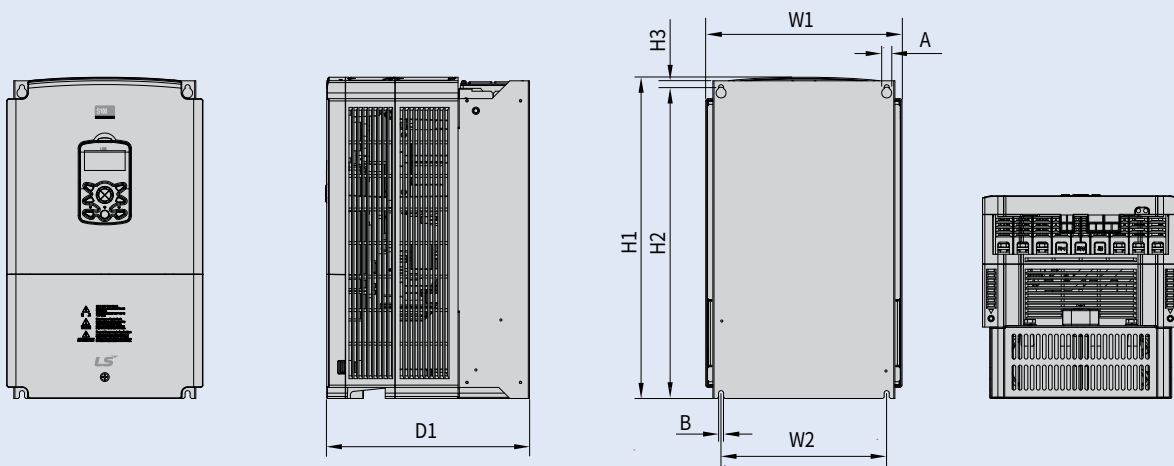

Unit : mm(Inches), kg

Drive Capacity	W1	W2	H1	H2	H3	D1	A	B	Ø	Weight
LSLV0300S100-4 ¹⁾	275 (10.8)	232 (9.13)	450 (17.7)	428.5	14	284 (11.2)	7 (0.28)	7 (0.28)	-	26

¹⁾ EMC filter built-in Class3

LSLV0370S100-4 / 0450S100-4

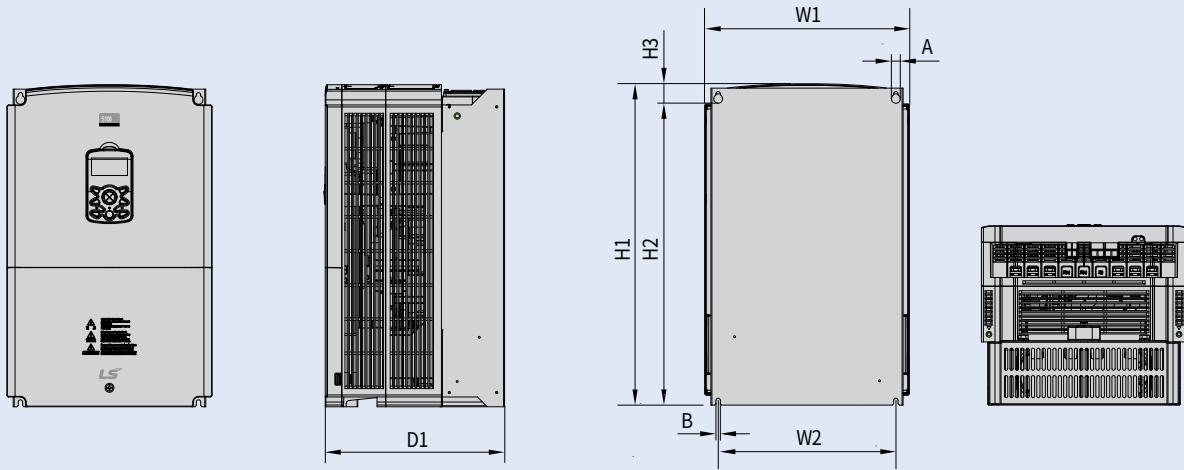

Unit : mm(Inches), kg

Drive Capacity	W1	W2	H1	H2	H3	D1	A	B	Ø	Weight
LSLV0370S100-4 ¹⁾	325 (12.8)	282 (11.10)	510 (20.1)	486.5 (19.15)	16 (0.63)	284 (11.2)	7 (0.28)	7 (0.28)	-	35
LSLV0450S100-4 ¹⁾	325 (12.8)	282 (11.10)	510 (20.1)	486.5 (19.15)	16 (0.63)	284 (11.2)	7 (0.28)	7 (0.28)	-	35

¹⁾ EMC filter built-in Class3

LSLV0550S100-4 / 0750S100-4

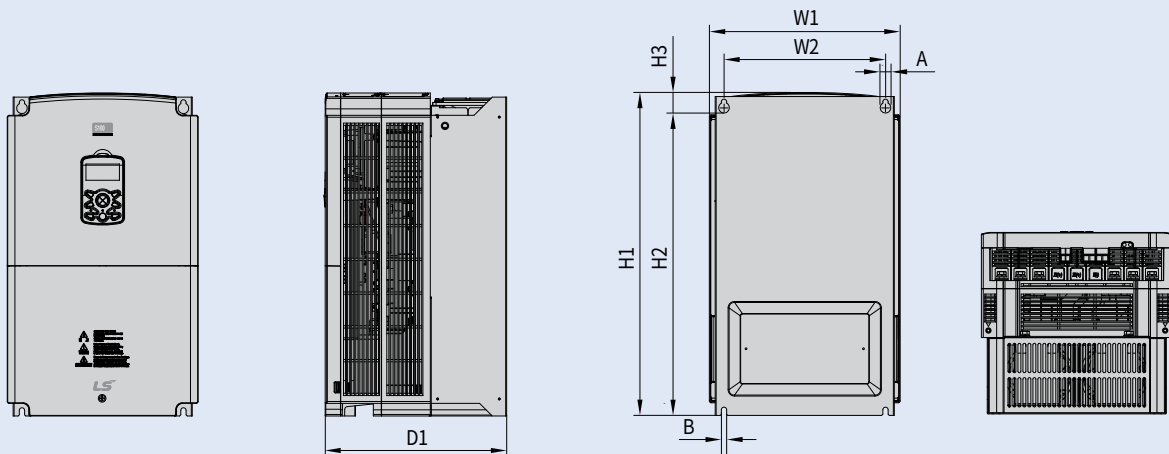

Unit : mm(Inches), kg

Drive Capacity	W1	W2	H1	H2	H3	D1	A	B	Ø	Weight
LSLV0550S100-4	325 (12.8)	275 (10.83)	550 (21.7)	524.5 (20.65)	16 (0.63)	309 (12.2)	9 (0.35)	9 (0.35)	-	43
LSLV0750S100-4	325 (12.8)	275 (10.83)	550 (21.7)	524.5 (20.65)	16 (0.63)	309 (12.2)	9 (0.35)	9 (0.35)	-	43

IP66(NEMA4X) 0.4~4.0kW

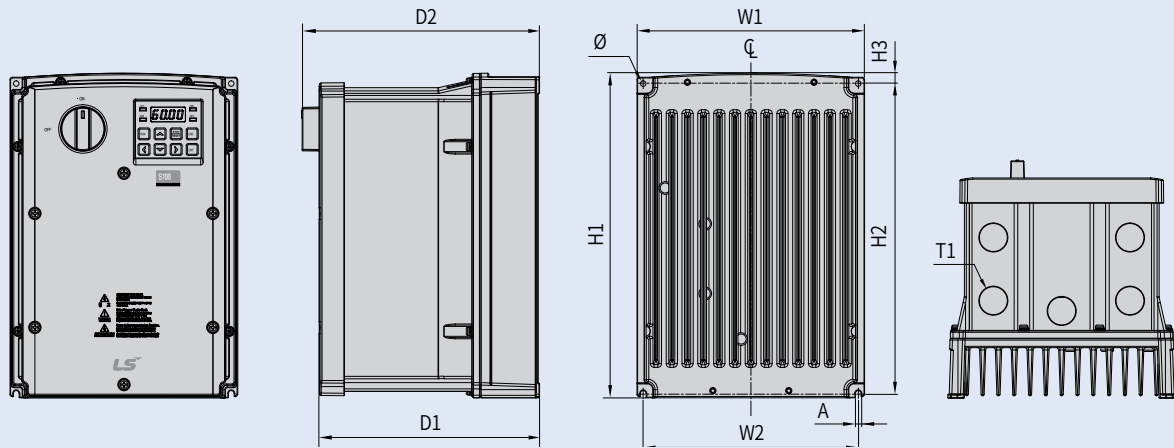

Unit : mm(Inches), kg

Drive Capacity	W1	W2	H1	H2	H3	D1	D2	A	Ø	T1	T2	Weight
LSLV0004S100-1 ¹⁾	180 (7.09)	170 (6.69)	256.6 (1010)	245 (9.65)	8.2 (0.32)	174.2 (6.86)	188.2 (7.41)	4.5 (0.18)	4.5 (0.18)	22 (0.87)	-	3.7
LSLV0004S100-2												3.6
LSLV0008S100-2												3.6
LSLV0008S100-1 ¹⁾	220 (8.66)	204 (8.03)	258.8 (10.19)	241 (9.49)	11.8 (0.46)	201 (7.91)	215 (8.46)	5.5 (0.22)	5.5 (0.22)	22.3 (0.88)	28.6 (1.13)	5.3
LSLV0015S100-1 ¹⁾												5.5
LSLV0022S100-1 ¹⁾												5.6
LSLV0015S100-2												5.2
LSLV0022S100-2												5.4
LSLV0037S100-2												5.5
LSLV0040S100-2												5.5
LSLV0004S100-4 ¹⁾	180 (7.09)	170 (6.69)	256.6 (1010)	245 (9.65)	8.2 (0.32)	174.2 (6.86)	188.2 (7.41)	4.5 (0.18)	4.5 (0.18)	22 (0.87)	-	3.7
LSLV0008S100-4 ¹⁾												3.7
LSLV0015S100-4 ¹⁾												5.3
LSLV0022S100-4 ¹⁾	220 (8.66)	204 (8.03)	258.8 (10.19)	241 (9.49)	11.8 (0.46)	201 (7.91)	215 (8.46)	5.5 (0.22)	5.5 (0.22)	22.3 (0.88)	28.6 (1.13)	5.5
LSLV0037S100-4 ¹⁾												5.6
LSLV0040S100-4 ¹⁾												5.6

¹⁾ EMC filter built-in Class3

IP66(NEMA4X) 5.5~7.5kW

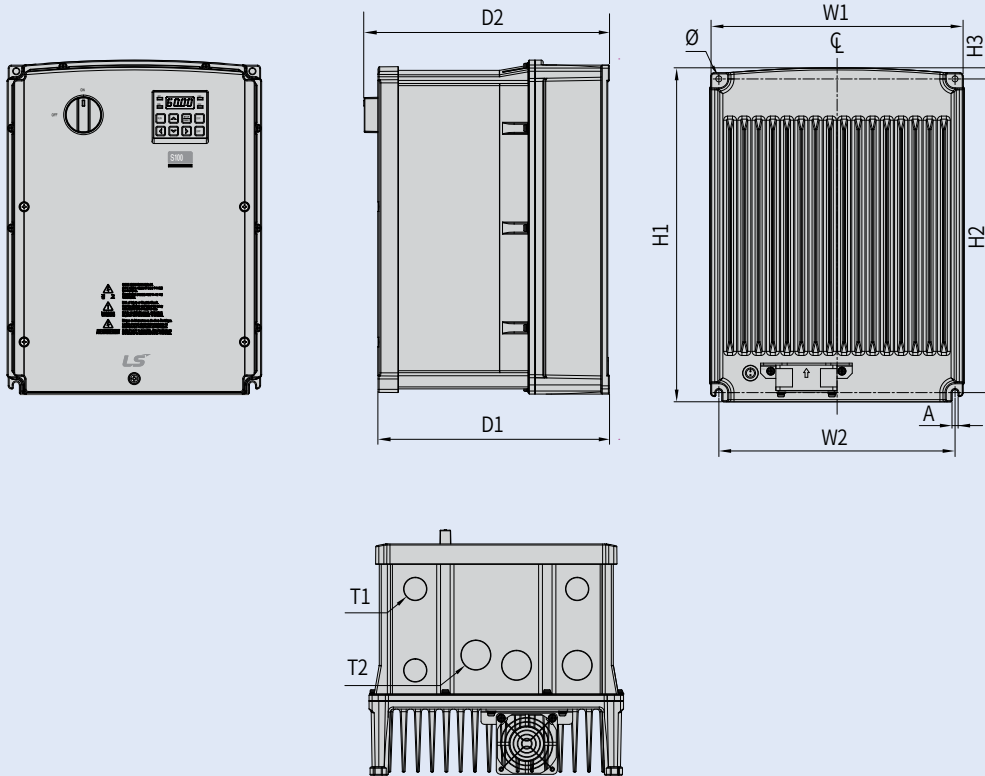

Unit : mm(Inches), kg

Drive Capacity	W1	W2	H1	H2	H3	D1	D2	A	Ø	T1	T2	Weight
LSLV0055S100-2X	250 (9.84)	232 (9.13)	328 (12.91)	308 (12.13)	11 (0.43)	227.2 (8.94)	241.2 (9.50)	6 (0.24)	6 (0.24)	22 (0.87)	28.6 (1.13)	8.8
LSLV0075S100-2X	250 (9.84)	232 (9.13)	328 (12.91)	308 (12.13)	11 (0.43)	227.2 (8.94)	241.2 (9.50)	6 (0.24)	6 (0.24)	22 (0.87)	28.6 (1.13)	8.8
LSLV0055S100-4X ¹⁾	250 (9.84)	232 (9.13)	328 (12.91)	308 (12.13)	11 (0.43)	227.2 (8.94)	241.2 (9.50)	6 (0.24)	6 (0.24)	22 (0.87)	28.6 (1.13)	8.8
LSLV0075S100-4X ¹⁾	250 (9.84)	232 (9.13)	328 (12.91)	308 (12.13)	11 (0.43)	227.2 (8.94)	241.2 (9.50)	6 (0.24)	6 (0.24)	22 (0.87)	28.6 (1.13)	8.9

¹⁾ EMC filter built-in Class3

IP66(NEMA4X) 11~22kW

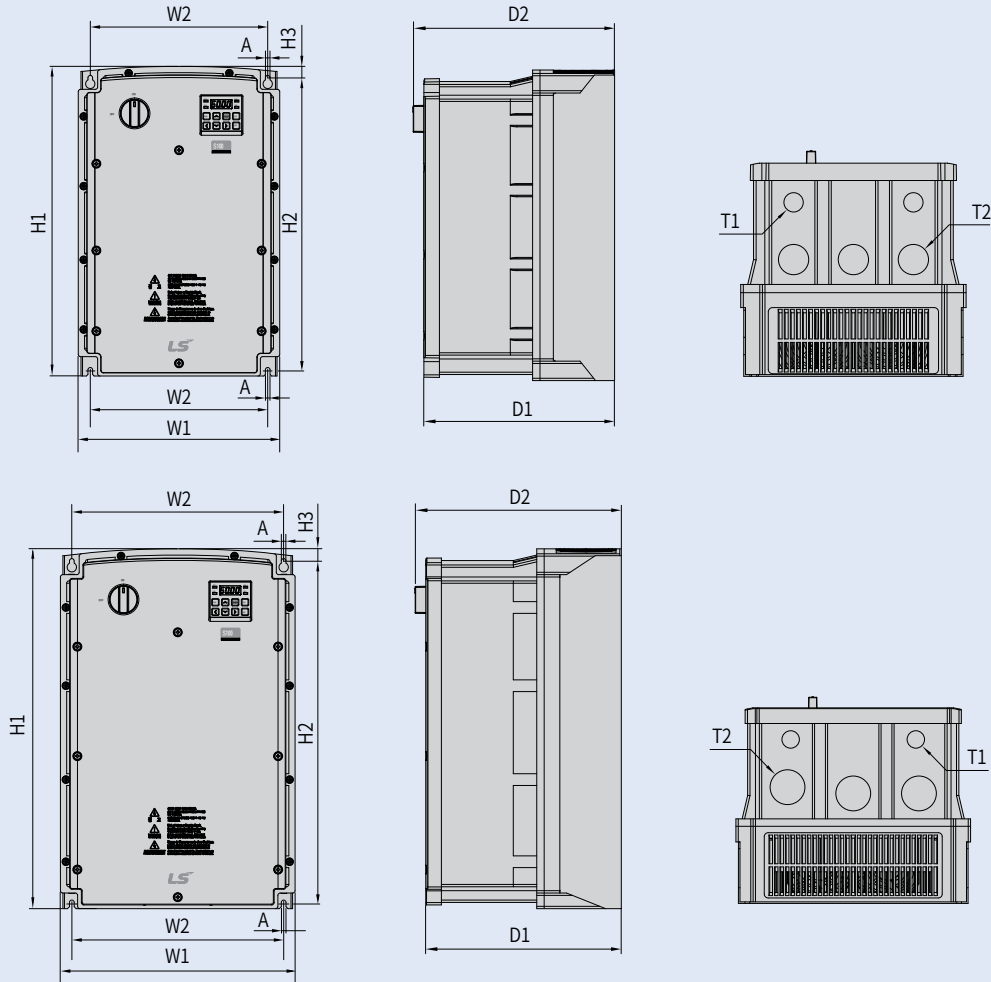

Unit : mm(Inches), kg

Drive Capacity	W1	W2	H1	H2	H3	D1	D2	A	Ø	T1	T2	Weight
LSLV0110S100-2X	260 (10.24)	229 (9.02)	399.6 (15.73)	377 (14.84)	14.6 (0.57)	245.4 (9.66)	259.6 (10.22)	6 (0.24)	-	22.3 (0.88)	34.9 (1.37)	9.4
LSLV0150S100-2X	300 (11.81)	270.8 (10.66)	460 (18.11)	436.5 (17.19)	15.5 (0.61)	250 (9.84)	264 (10.39)	6 (0.24)	-	22.3 (0.88)	44.5 (1.75)	11.9
LSLV0110S100-4X ¹⁾	260 (10.24)	229 (9.02)	399.6 (15.73)	377 (14.84)	14.6 (0.57)	245.4 (9.66)	259.6 (10.22)	6 (0.24)	-	22.3 (0.88)	34.9 (1.37)	9.6
LSLV0150S100-4X ¹⁾	260 (10.24)	229 (9.02)	399.6 (15.73)	377 (14.84)	14.6 (0.57)	245.4 (9.66)	259.6 (10.22)	6 (0.24)	-	22.3 (0.88)	34.9 (1.37)	9.8
LSLV0185S100-4X ¹⁾	300 (11.81)	270.8 (10.66)	460 (18.11)	436.5 (17.19)	15.5 (0.61)	250 (9.84)	264 (10.39)	6 (0.24)	-	22.3 (0.88)	44.5 (1.75)	12.4
LSLV0220S100-4X ¹⁾	300 (11.81)	270.8 (10.66)	460 (18.11)	436.5 (17.19)	15.5 (0.61)	250 (9.84)	264 (10.39)	6 (0.24)	-	22.3 (0.88)	44.5 (1.75)	12.4

¹⁾ EMC filter built-in Class3

Communication Option Module (Installation Example)

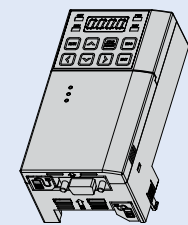

Option Module

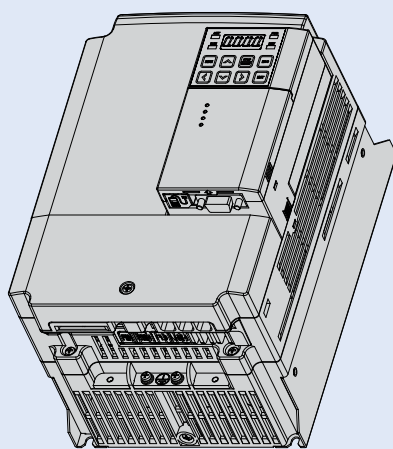
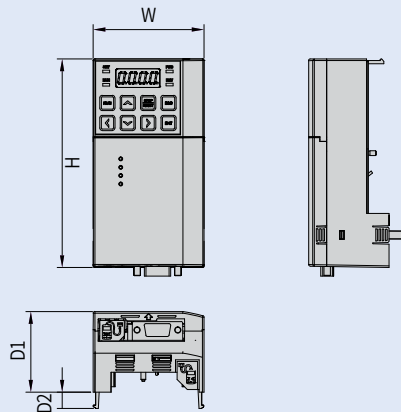

Option Module + Drive

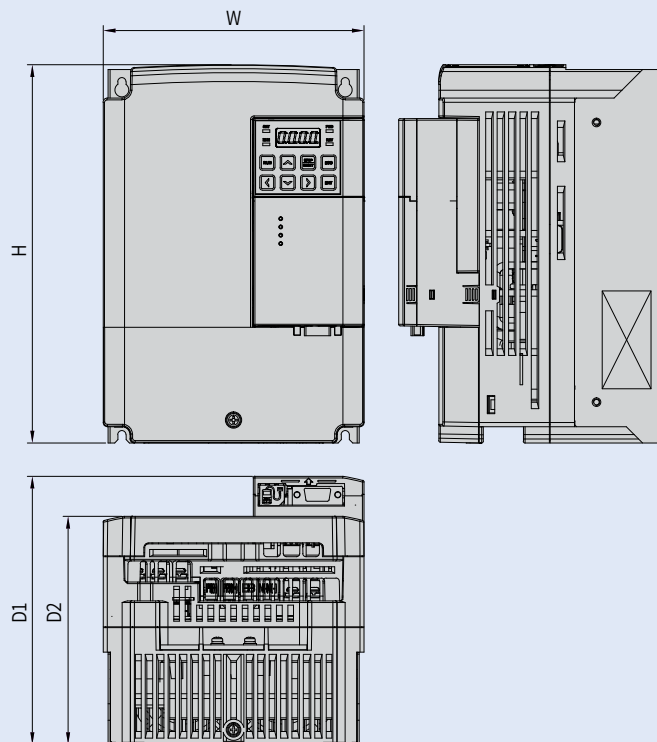

Unit : mm(Inches)

Item	W	H	D1	D2
Option Module	68 [2.66]	128 [5.03]	49.4 [1.94]	10 [0.39]
Drive + Option Module	160 [6.29]	232 [9.13]	164.6 [6.48]	140 [5.51]

Conduit Option

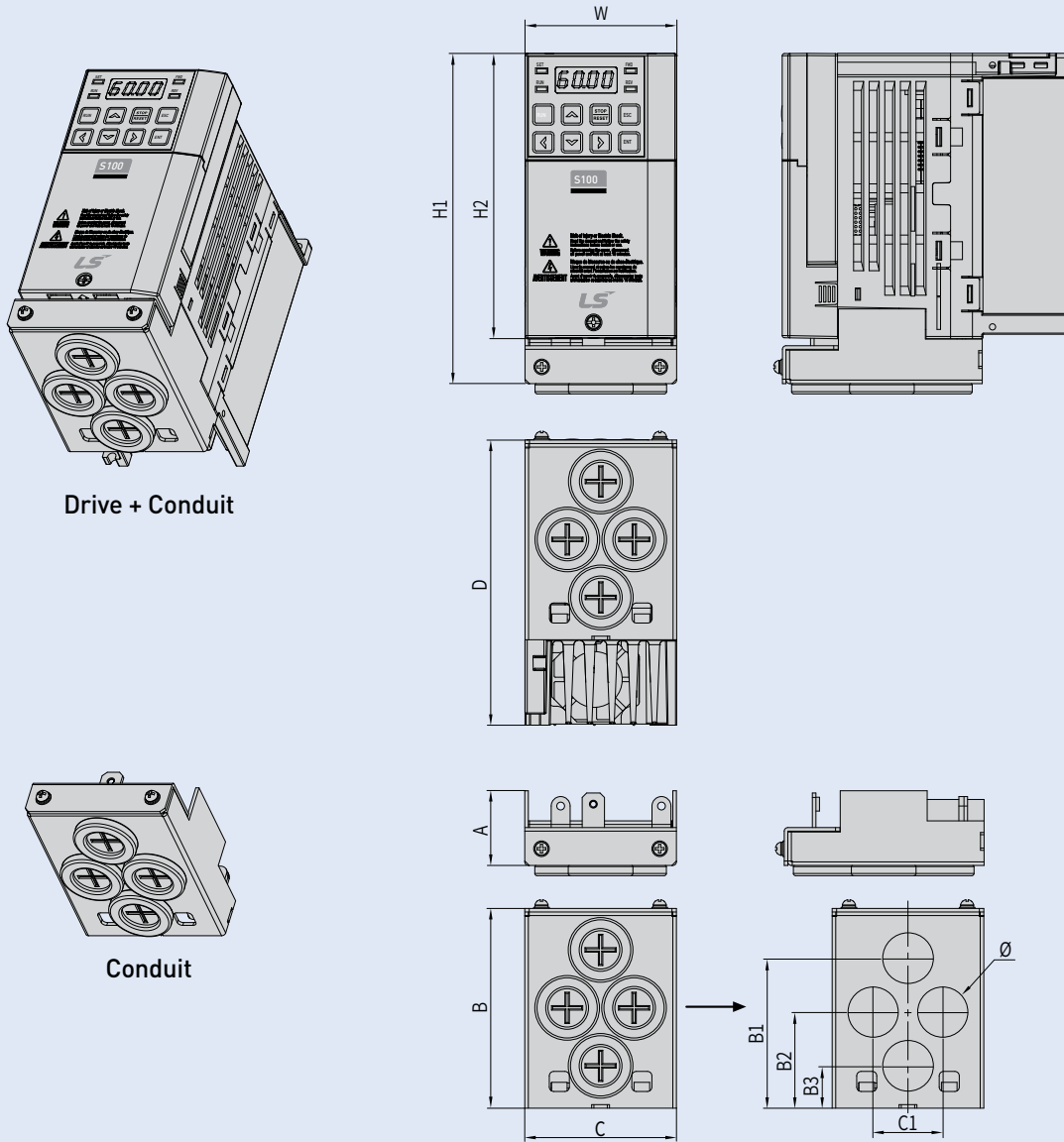

* Wit hout rubber packing

Unit : mm(Inches), kg

Drive Capacity	W	H1	H2	D	A	B	C	B1	B2	B3	C1	Ø	Weight
LSLV0004S100-2	68 (2.68)	148.2 (5.83)	128 (5.04)	123 (4.84)	33.5 (1.32)	89.6 (3.53)	68 (2.68)	71 (2.80)	45 (1.77)	19 (0.75)	30 (1.18)	22.3 (0.88)	1.2
LSLV0004S100-4	68 (2.68)	148.2 (5.83)	128 (5.04)	123 (4.84)	33.5 (1.32)	89.6 (3.53)	68 (2.68)	71 (2.80)	45 (1.77)	19 (0.75)	30 (1.18)	22.3 (0.88)	1.2
LSLV0004S100-1	68 (2.68)	148.2 (5.83)	128 (5.04)	128 (5.04)	33.5 (1.32)	89.6 (3.53)	68 (2.68)	71 (2.80)	45 (1.77)	19 (0.75)	30 (1.18)	22.3 (0.88)	1.2
LSLV0008S100-2	68 (2.68)	148.2 (5.83)	128 (5.04)	128 (5.04)	33.5 (1.32)	89.6 (3.53)	68 (2.68)	71 (2.80)	45 (1.77)	19 (0.75)	30 (1.18)	22.3 (0.88)	1.2
LSLV0008S100-4	68 (2.68)	148.2 (5.83)	128 (5.04)	128 (5.04)	33.5 (1.32)	89.6 (3.53)	68 (2.68)	71 (2.80)	45 (1.77)	19 (0.75)	30 (1.18)	22.3 (0.88)	1.2

* CONDUIT SIZE : 1/2 INCHES (Ø : 22.3 MM)

Conduit Option

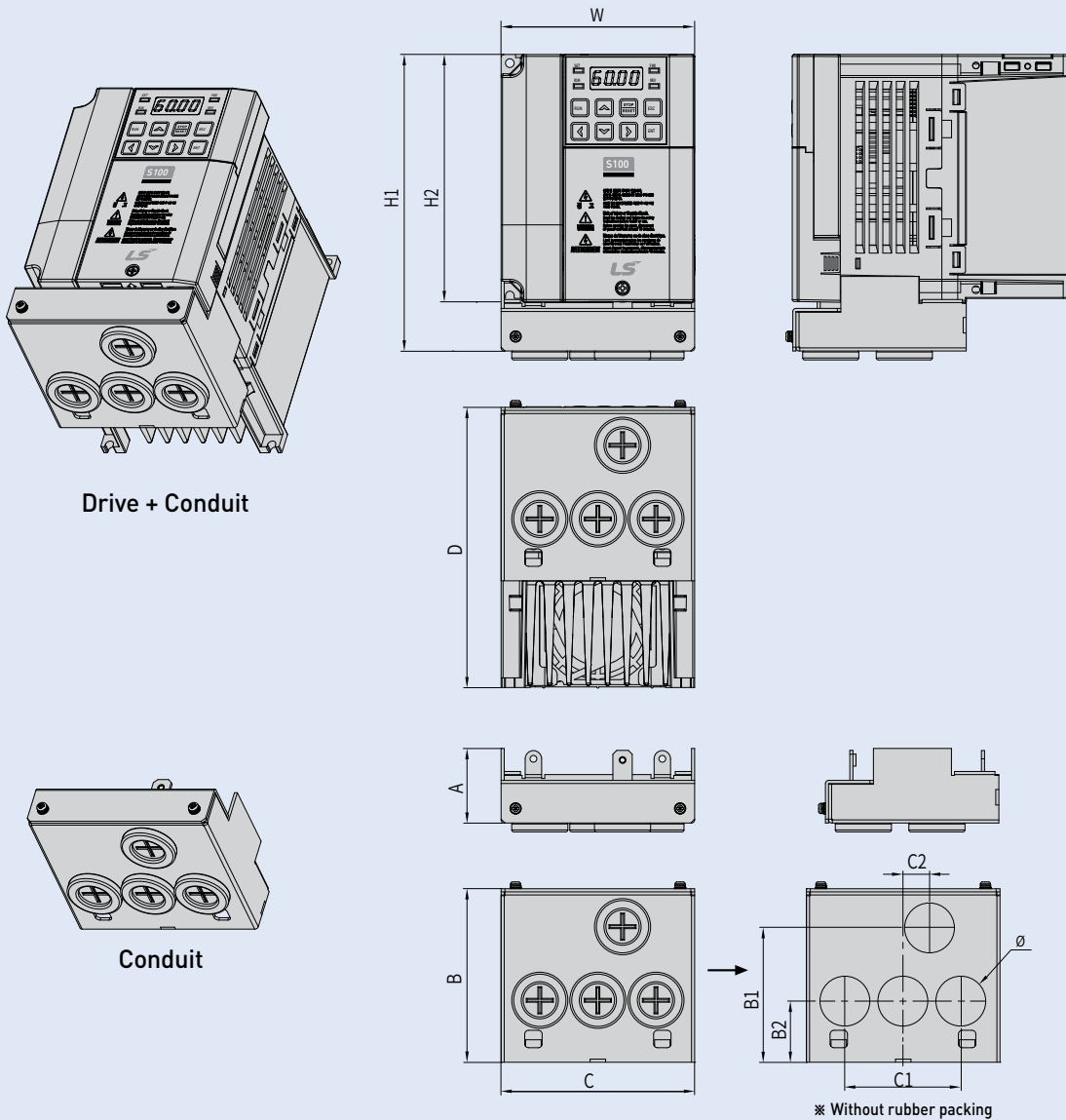

Unit : mm(Inches), kg

Drive Capacity	W	H1	H2	D	A	B	C	B1	B2	C1	C2	Ø	Weight
LSLV0008S100-1	100 (3.94)	153.2 (6.03)	128 (5.04)	130 (5.12)	38.5 (1.52)	89.6 (3.53)	100 (3.94)	70 (2.76)	32 (1.26)	60 (2.36)	12.8 (0.50)	22.3 (0.88)	1.7
LSLV0015S100-2	100 (3.94)	153.2 (6.03)	128 (5.04)	130 (5.12)	38.5 (1.52)	89.6 (3.53)	100 (3.94)	70 (2.76)	32 (1.26)	60 (2.36)	12.8 (0.50)	22.3 (0.88)	1.7
LSLV0015S100-4	100 (3.94)	153.2 (6.03)	128 (5.04)	130 (5.12)	38.5 (1.52)	89.6 (3.53)	100 (3.94)	70 (2.76)	32 (1.26)	60 (2.36)	12.8 (0.50)	22.3 (0.88)	1.7
LSLV0015S100-1	100 (3.94)	153.2 (6.03)	128 (5.04)	130 (5.12)	38.5 (1.52)	89.6 (3.53)	100 (3.94)	70 (2.76)	32 (1.26)	60 (2.36)	12.8 (0.50)	22.3 (0.88)	1.7
LSLV0022S100-2	100 (3.94)	153.2 (6.03)	128 (5.04)	130 (5.12)	38.5 (1.52)	89.6 (3.53)	100 (3.94)	70 (2.76)	32 (1.26)	60 (2.36)	12.8 (0.50)	22.3 (0.88)	1.9
LSLV0022S100-4	100 (3.94)	153.2 (6.03)	128 (5.04)	130 (5.12)	38.5 (1.52)	89.6 (3.53)	100 (3.94)	70 (2.76)	32 (1.26)	60 (2.36)	12.8 (0.50)	22.3 (0.88)	1.9

※ CONDUIT SIZE : 1/2 INCHES (Ø : 22.3 MM)

Conduit Option

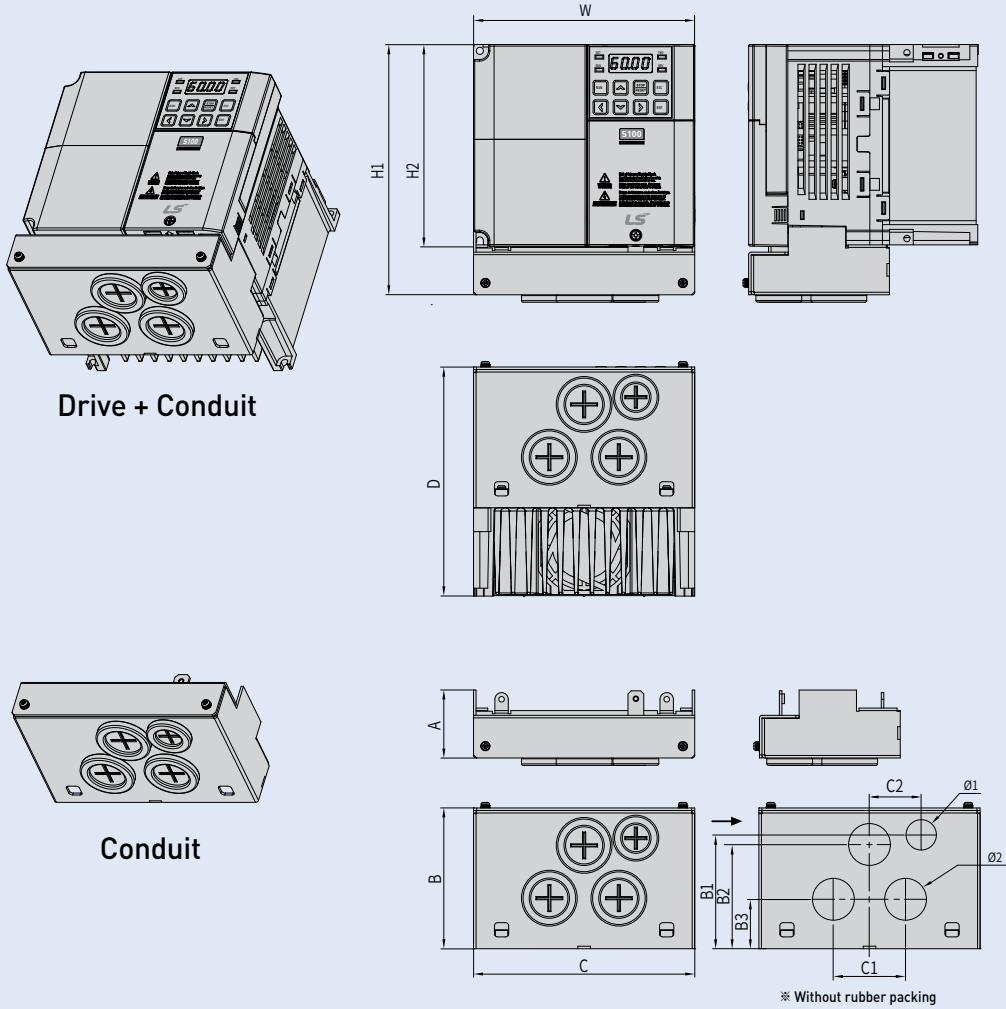

Unit : mm(Inches), kg

Drive Capacity	W	H1	H2	D	A	B	C	B1	B2	B3	C1	C2	Ø1	Ø2	Weight
LSLV0022S100-1	140 (5.51)	158.4 (6.24)	128 (5.04)	145 (5.71)	43 (1.69)	89.1 (3.51)	140 (5.51)	70 (2.76)	65.4 (2.57)	32 (1.26)	44 (1.73)	32.8 (1.29)	22.3 (0.88)	28.6 (1.13)	2.6
LSLV0037S100-2	140 (5.51)	158.4 (6.24)	128 (5.04)	145 (5.71)	43 (1.69)	89.1 (3.51)	140 (5.51)	70 (2.76)	65.4 (2.57)	32 (1.26)	44 (1.73)	32.8 (1.29)	22.3 (0.88)	28.6 (1.13)	2.6
LSLV0037S100-4	140 (5.51)	158.4 (6.24)	128 (5.04)	145 (5.71)	43 (1.69)	89.1 (3.51)	140 (5.51)	70 (2.76)	65.4 (2.57)	32 (1.26)	44 (1.73)	32.8 (1.29)	22.3 (0.88)	28.6 (1.13)	2.6
LSLV0040S100-2	140 (5.51)	158.4 (6.24)	128 (5.04)	145 (5.71)	43 (1.69)	89.1 (3.51)	140 (5.51)	70 (2.76)	65.4 (2.57)	32 (1.26)	44 (1.73)	32.8 (1.29)	22.3 (0.88)	28.6 (1.13)	2.6
LSLV0040S100-4	140 (5.51)	158.4 (6.24)	128 (5.04)	145 (5.71)	43 (1.69)	89.1 (3.51)	140 (5.51)	70 (2.76)	65.4 (2.57)	32 (1.26)	44 (1.73)	32.8 (1.29)	22.3 (0.88)	28.6 (1.13)	2.6

* CONDUIT SIZE : 1/2 INCHES (Ø : 22.3 MM), 3/4 INCHES (Ø : 28.6 MM)

Conduit Option

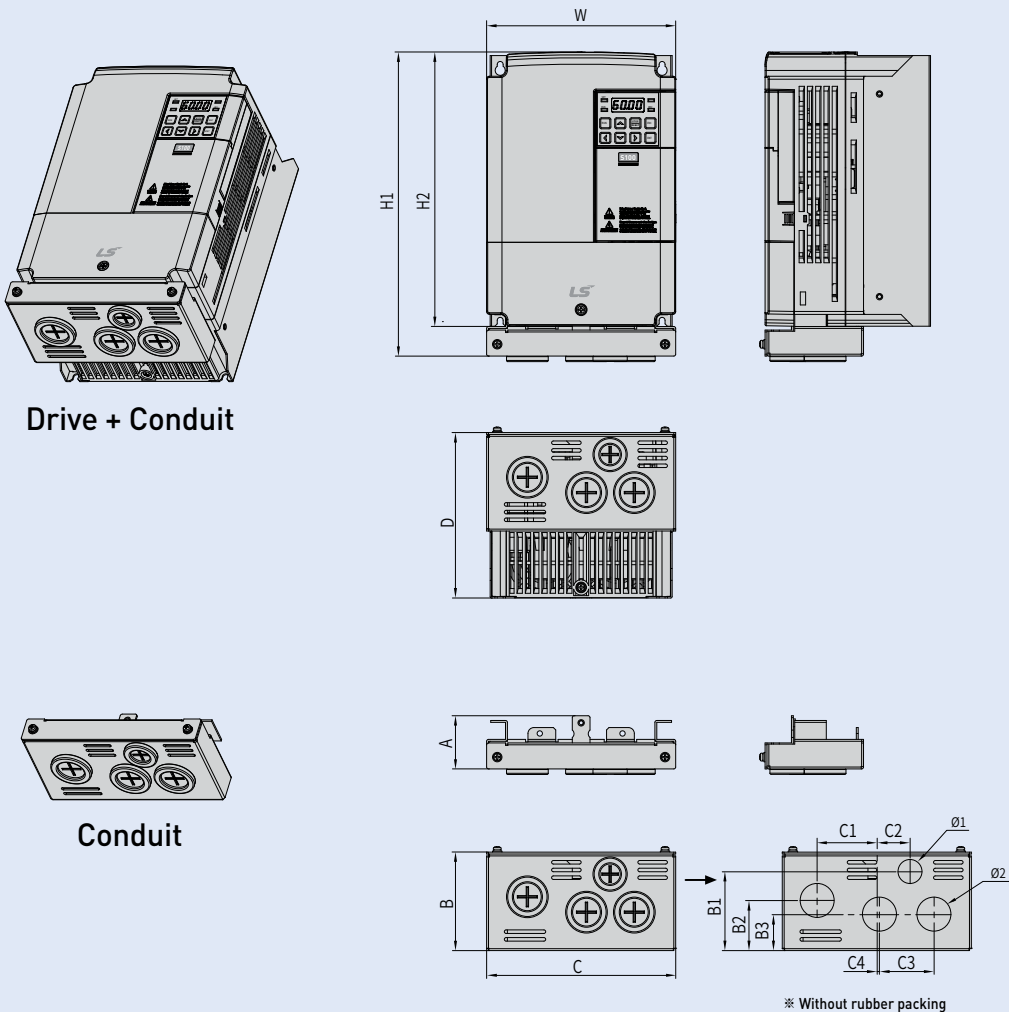

Unit : mm(Inches), kg

Drive Capacity	W	H1	H2	D	A	B	C	B1	B2	B3	C1	C2	C3	C4	Ø1	Ø2	Weight
LSLV0055S100-2	160 (6.30)	257.3 (10.13)	232 (9.13)	140 (5.51)	45 (1.77)	83.3 (3.28)	160 (6.30)	64.7 (2.55)	45.5 (1.79)	32.5 (1.27)	45.5 (1.79)	24.5 (0.96)	40.5 (1.59)	4.5 (0.18)	22.3 (0.88)	28.6 (6.30)	3.65
LSLV0055S100-4 ¹⁾	160 (6.30)	257.3 (10.13)	232 (9.13)	140 (5.51)	45 (1.77)	83.3 (3.28)	160 (6.30)	64.7 (2.55)	45.5 (1.79)	32.5 (1.27)	45.5 (1.79)	24.5 (0.96)	40.5 (1.59)	4.5 (0.18)	22.3 (0.88)	28.6 (6.30)	3.65
LSLV0075S100-2	160 (6.30)	257.3 (10.13)	232 (9.13)	140 (5.51)	45 (1.77)	83.3 (3.28)	160 (6.30)	64.7 (2.55)	45.5 (1.79)	32.5 (1.27)	45.5 (1.79)	24.5 (0.96)	40.5 (1.59)	4.5 (0.18)	22.3 (0.88)	28.6 (6.30)	3.65
LSLV0075S100-4 ¹⁾	160 (6.30)	257.3 (10.13)	232 (9.13)	140 (5.51)	45 (1.77)	83.3 (3.28)	160 (6.30)	64.7 (2.55)	45.5 (1.79)	32.5 (1.27)	45.5 (1.79)	24.5 (0.96)	40.5 (1.59)	4.5 (0.18)	22.3 (0.88)	28.6 (6.30)	3.65
LSLV0110S100-2	180 (7.87)	315.3 (12.41)	290 (11.42)	163 (6.42)	49 (1.93)	89.3 (3.52)	180 (7.09)	70 (2.76)	45.5 (1.79)	33 (1.30)	54.5 (2.15)	29 (1.14)	53 (2.09)	2.5 (0.10)	22.3 (0.88)	35 (1.38)	5.05
LSLV0110S100-4 ¹⁾	180 (7.87)	315.3 (12.41)	290 (11.42)	163 (6.42)	49 (1.93)	89.3 (3.52)	180 (7.09)	70 (2.76)	45.5 (1.79)	33 (1.30)	54.5 (2.15)	29 (1.14)	53 (2.09)	2.5 (0.10)	22.3 (0.88)	35 (1.38)	5.05
LSLV0150S100-2	220 (8.67)	382 (15.04)	350 (13.78)	187 (7.36)	63.5 (2.50)	90.6 (3.57)	215 (8.46)	70.8 (2.79)	47 (1.85)	34 (1.34)	66 (2.60)	32 (1.26)	67 (2.64)	-	22.3 (0.88)	44.5 (1.75)	5.15
LSLV0150S100-4 ¹⁾	180 (7.87)	315.3 (12.41)	290 (11.42)	163 (6.42)	49 (1.93)	89.3 (3.52)	180 (7.09)	70 (2.76)	45.5 (1.79)	33 (1.30)	54.5 (2.15)	29 (1.14)	53 (2.09)	2.5 (0.10)	22.3 (0.88)	35 (1.38)	5.05
LSLV0185S100-4 ¹⁾	220 (8.67)	382 (15.04)	350 (13.78)	187 (7.36)	63.5 (2.50)	90.6 (3.57)	215 (8.46)	70.8 (2.79)	47 (1.85)	34 (1.34)	66 (2.60)	32 (1.26)	67 (2.64)	-	22.3 (0.88)	44.5 (1.75)	8.05
LSLV0220S100-4 ¹⁾	220 (8.67)	382 (15.04)	350 (13.78)	187 (7.36)	63.5 (2.50)	90.6 (3.57)	215 (8.46)	70.8 (2.79)	47 (1.85)	34 (1.34)	66 (2.60)	32 (1.26)	67 (2.64)	-	22.3 (0.88)	44.5 (1.75)	8.05

¹⁾ EMC LTERBUILT-INCLa

* CONDUIT SIZE: 1/2 INCHES (Ø: 22.3 mm), 3/4 INCHES (Ø: 28.6 mm) 1 INCHES (Ø : 35 mm), 1+1/4 INCHES (Ø : 44.5 mm)

Flange Option

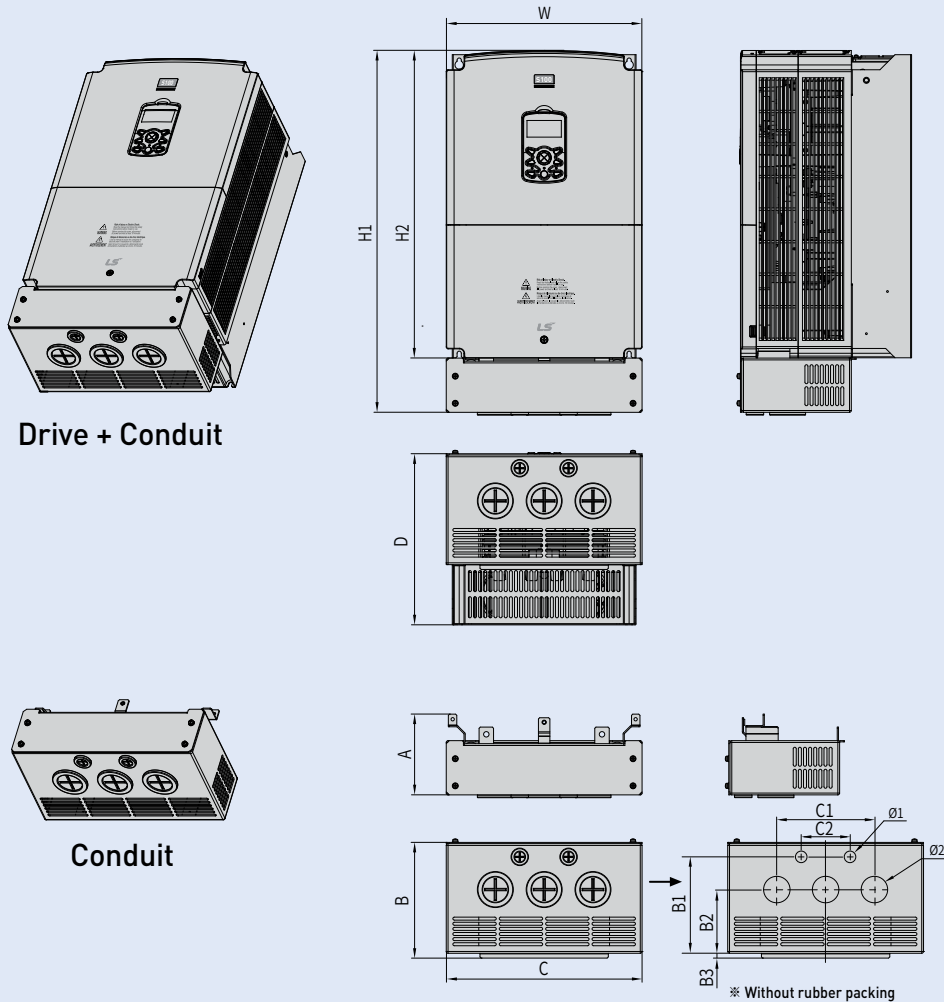

Unit : mm(Inches), kg

Drive Capacity	W	H1	H2	D	A	B	C	B1	B2	B3	C1	C2	Ø1	Ø2	Weight
LSLV0300S100-4 ¹⁾	275 (10.83)	521.5 (20.53)	450 (17.72)	284 (11.18)	112.5 (4.43)	192 (7.56)	275 (10.83)	160 (6.30)	105.8 (4.17)	8 (0.32)	162 (6.38)	81 (3.19)	22.3 (0.88)	44.5 (1.75)	28.7
LSLV0370S100-4 ¹⁾	325 (12.80)	600.5 (23.64)	510 (20.09)	284 (11.18)	134 (5.28)	192 (7.56)	325 (12.80)	160 (6.30)	105.8 (4.17)	8 (0.32)	162 (6.38)	81 (3.19)	22.3 (0.88)	50.8 (2.00)	38.4
LSLV0450S100-4 ¹⁾	325 (12.80)	600.5 (23.64)	510 (20.09)	284 (11.18)	134 (5.28)	192 (7.56)	325 (12.80)	160 (6.30)	105.8 (4.17)	8 (0.32)	162 (6.38)	81 (3.19)	22.3 (0.88)	50.8 (2.00)	38.4
LSLV0550S100-4 ¹⁾	325 (12.80)	685.5 (26.99)	550 (21.65)	309 (12.17)	183 (7.20)	187 (7.36)	325 (12.80)	155 (6.10)	100.8 (3.97)	8 (0.32)	192 (7.56)	81 (3.19)	22.3 (0.88)	63.5 (2.50)	47.2
LSLV0750S100-4 ¹⁾	325 (12.80)	685.5 (26.99)	550 (21.65)	309 (12.17)	183 (7.20)	187 (7.36)	325 (12.80)	155 (6.10)	100.8 (3.97)	8 (0.32)	192 (7.56)	81 (3.19)	22.3 (0.88)	63.5 (2.50)	47.2

¹⁾ EMC LTERBUILT-INCLASS3 * CONDUIT SIZE: 1/2 INCHES (Ø: 22.3MM), 1+1/4 INCHES (Ø: 44.5MM) 1+1/2 INCHES (Ø : 50.8 MM), 2 INCHES (Ø : 63.5 MM)

Flange Option

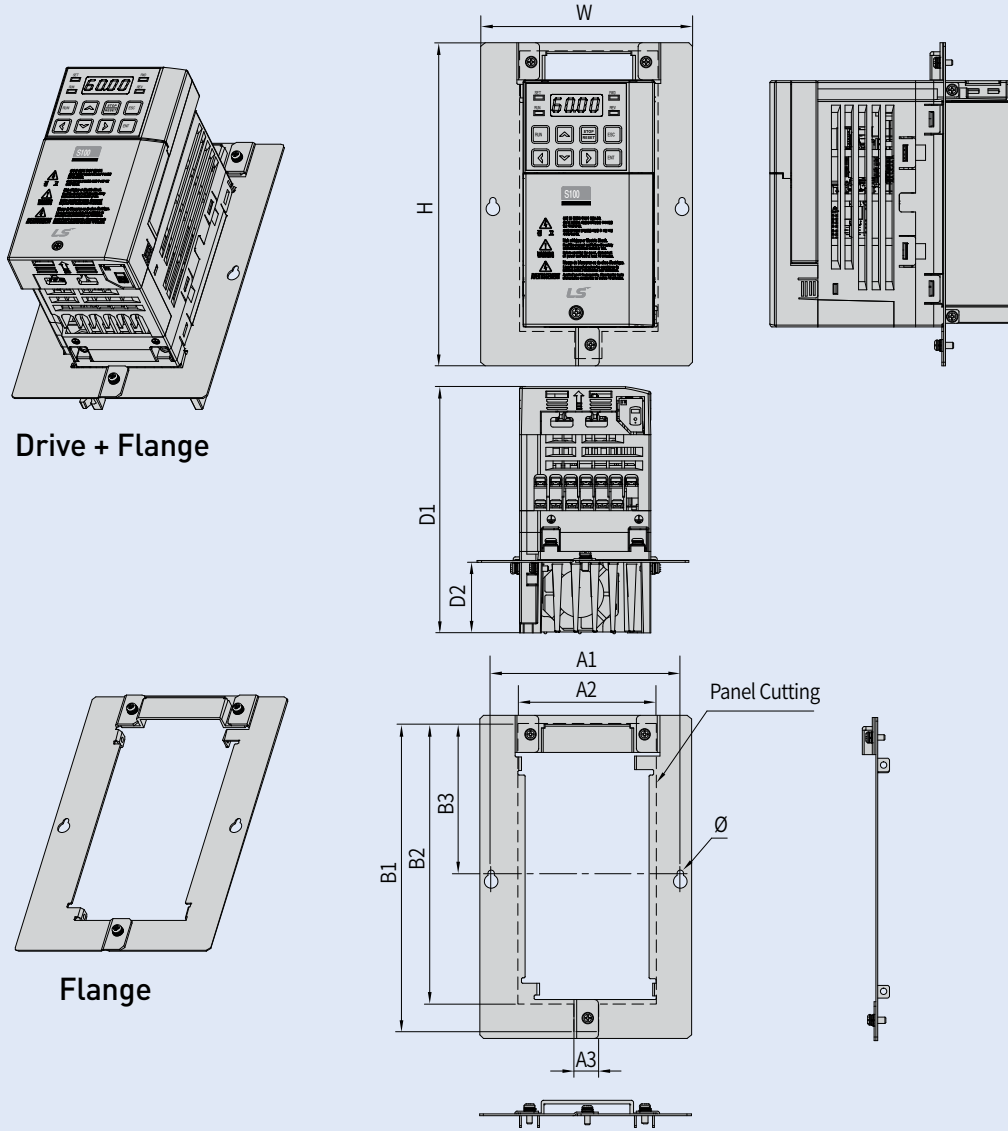

Unit : mm(Inches), kg

Drive Capacity	W	H	D1	D2	A1	A2	A3	B1	B2	B3	Ø	Weight
LSLV0004S100-2	110 (4.33)	168 (6.61)	123 (4.84)	31.8 (1.25)	98 (3.86)	72 (2.83)	14 (0.55)	159.8 (6.29)	145.4 (5.72)	77.9 (3.07)	3.5 (0.14)	1.1
LSLV0004S100-4	110 (4.33)	168 (6.61)	123 (4.84)	31.8 (1.25)	98 (3.86)	72 (2.83)	14 (0.55)	159.8 (6.29)	145.4 (5.72)	77.9 (3.07)	3.5 (0.14)	1.1
LSLV0004S100-1	110 (4.33)	168 (6.61)	128 (5.04)	36.8 (1.45)	98 (3.86)	72 (2.83)	14 (0.55)	159.8 (6.29)	145.4 (5.72)	77.9 (3.07)	3.5 (0.14)	1.1
LSLV0008S100-2	110 (4.33)	168 (6.61)	128 (5.04)	36.8 (1.45)	98 (3.86)	72 (2.83)	14 (0.55)	159.8 (6.29)	145.4 (5.72)	77.9 (3.07)	3.5 (0.14)	1.1
LSLV0008S100-4	110 (4.33)	168 (6.61)	128 (5.04)	36.8 (1.45)	98 (3.86)	72 (2.83)	14 (0.55)	159.8 (6.29)	145.4 (5.72)	77.9 (3.07)	3.5 (0.14)	1.1

Flange Option

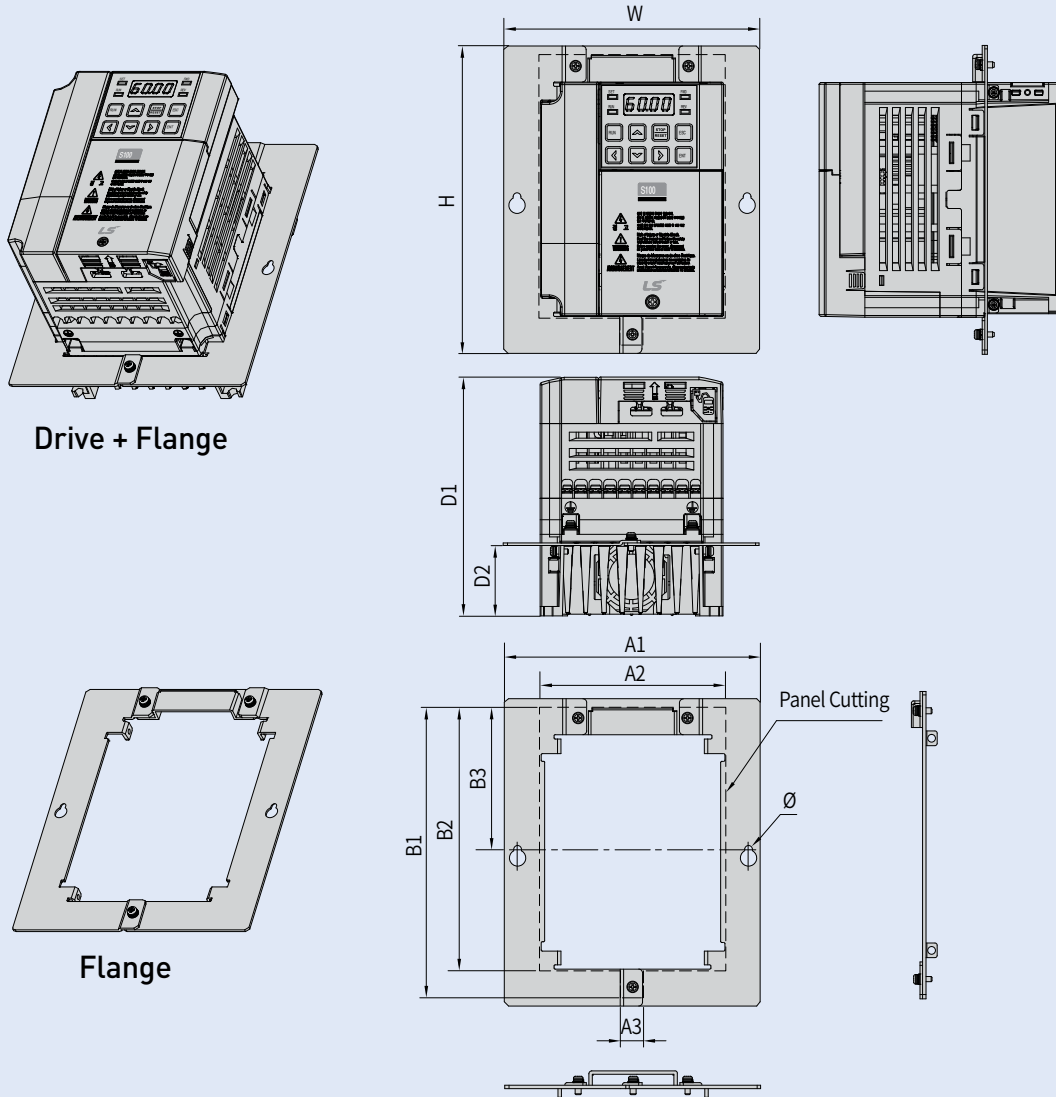

Unit : mm(Inches), kg

Drive Capacity	W	H	D1	D2	A1	A2	A3	B1	B2	B3	Ø	Weight
LSLV0008S100-1	140 (5.51)	168 (6.61)	130 (5.12)	38.2 (1.50)	140 (5.51)	102 (4.02)	14 (0.55)	159.8 (6.29)	144.4 (5.69)	77.9 (3.07)	4.5 (0.18)	1.6
LSLV0015S100-2	140 (5.51)	168 (6.61)	130 (5.12)	38.2 (1.50)	140 (5.51)	102 (4.02)	14 (0.55)	159.8 (6.29)	144.4 (5.69)	77.9 (3.07)	4.5 (0.18)	1.6
LSLV0015S100-4	140 (5.51)	168 (6.61)	130 (5.12)	38.2 (1.50)	140 (5.51)	102 (4.02)	14 (0.55)	159.8 (6.29)	144.4 (5.69)	77.9 (3.07)	4.5 (0.18)	1.6
LSLV0015S100-1	140 (5.51)	168 (6.61)	145 (5.71)	53.2 (2.09)	140 (5.51)	102 (4.02)	14 (0.55)	159.8 (6.29)	144.4 (5.69)	77.9 (3.07)	4.5 (0.18)	1.8
LSLV0022S100-2	140 (5.51)	168 (6.61)	145 (5.71)	53.2 (2.09)	140 (5.51)	102 (4.02)	14 (0.55)	159.8 (6.29)	144.4 (5.69)	77.9 (3.07)	4.5 (0.18)	1.8
LSLV0022S100-4	140 (5.51)	168 (6.61)	145 (5.71)	53.2 (2.09)	140 (5.51)	102 (4.02)	14 (0.55)	159.8 (6.29)	144.4 (5.69)	77.9 (3.07)	4.5 (0.18)	1.8

Flange Option

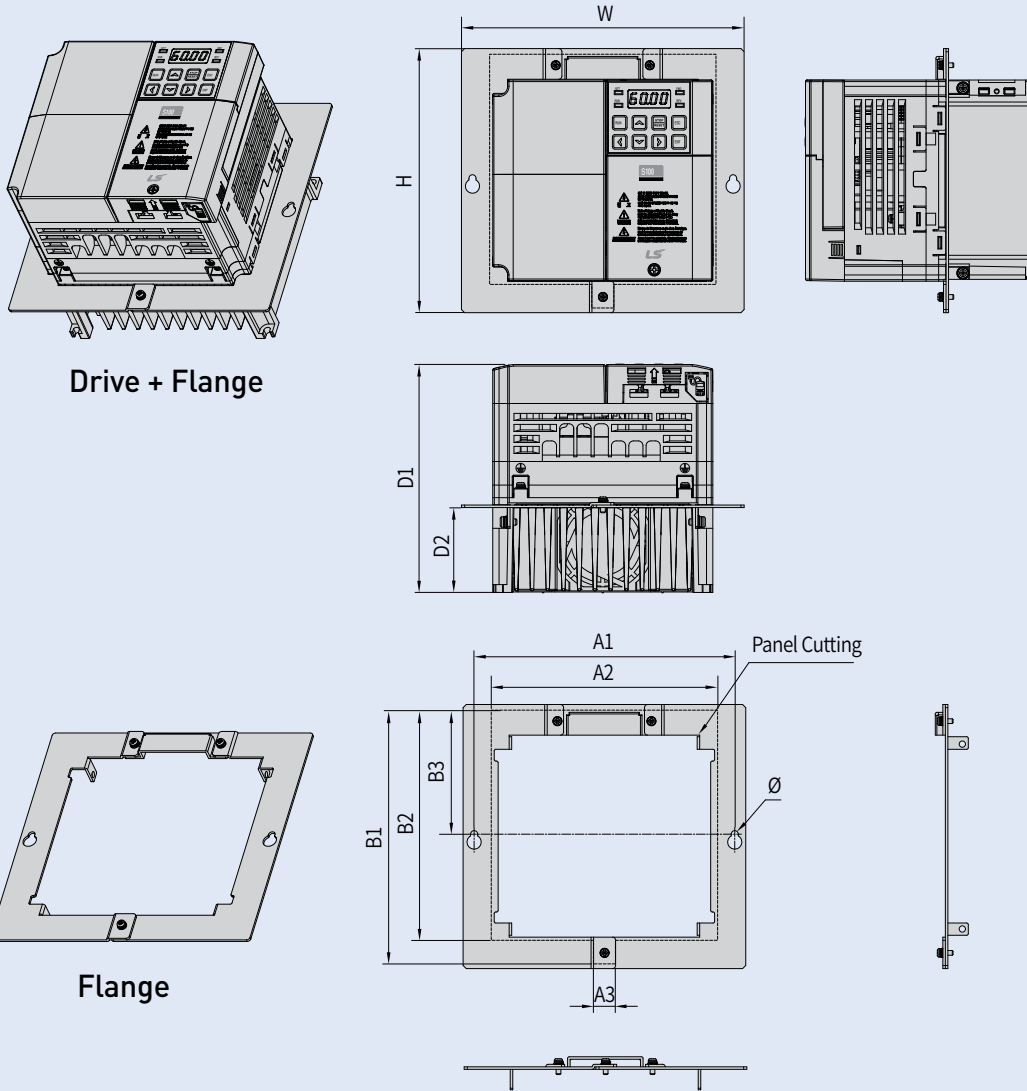

Unit : mm(Inches), kg

Drive Capacity	W	H	D1	D2	A1	A2	A3	B1	B2	B3	Ø	Weight
LSLV0022S100-1	179.8 (7.08)	168 (6.61)	145 (5.71)	54 (2.13)	165.8 (6.53)	144 (5.67)	14 (0.55)	161.4 (6.35)	146.4 (5.76)	78.9 (3.11)	4.5 (0.18)	2.3
LSLV0037S100-2	179.8 (7.08)	168 (6.61)	145 (5.71)	54 (2.13)	165.8 (6.53)	144 (5.67)	14 (0.55)	161.4 (6.35)	146.4 (5.76)	78.9 (3.11)	4.5 (0.18)	2.3
LSLV0037S100-4	179.8 (7.08)	168 (6.61)	145 (5.71)	54 (2.13)	165.8 (6.53)	144 (5.67)	14 (0.55)	161.4 (6.35)	146.4 (5.76)	78.9 (3.11)	4.5 (0.18)	2.3
LSLV0040S100-2	179.8 (7.08)	168 (6.61)	145 (5.71)	54 (2.13)	165.8 (6.53)	144 (5.67)	14 (0.55)	161.4 (6.35)	146.4 (5.76)	78.9 (3.11)	4.5 (0.18)	2.3
LSLV0040S100-4	179.8 (7.08)	168 (6.61)	145 (5.71)	54 (2.13)	165.8 (6.53)	144 (5.67)	14 (0.55)	161.4 (6.35)	146.4 (5.76)	78.9 (3.11)	4.5 (0.18)	2.3

Flange Option

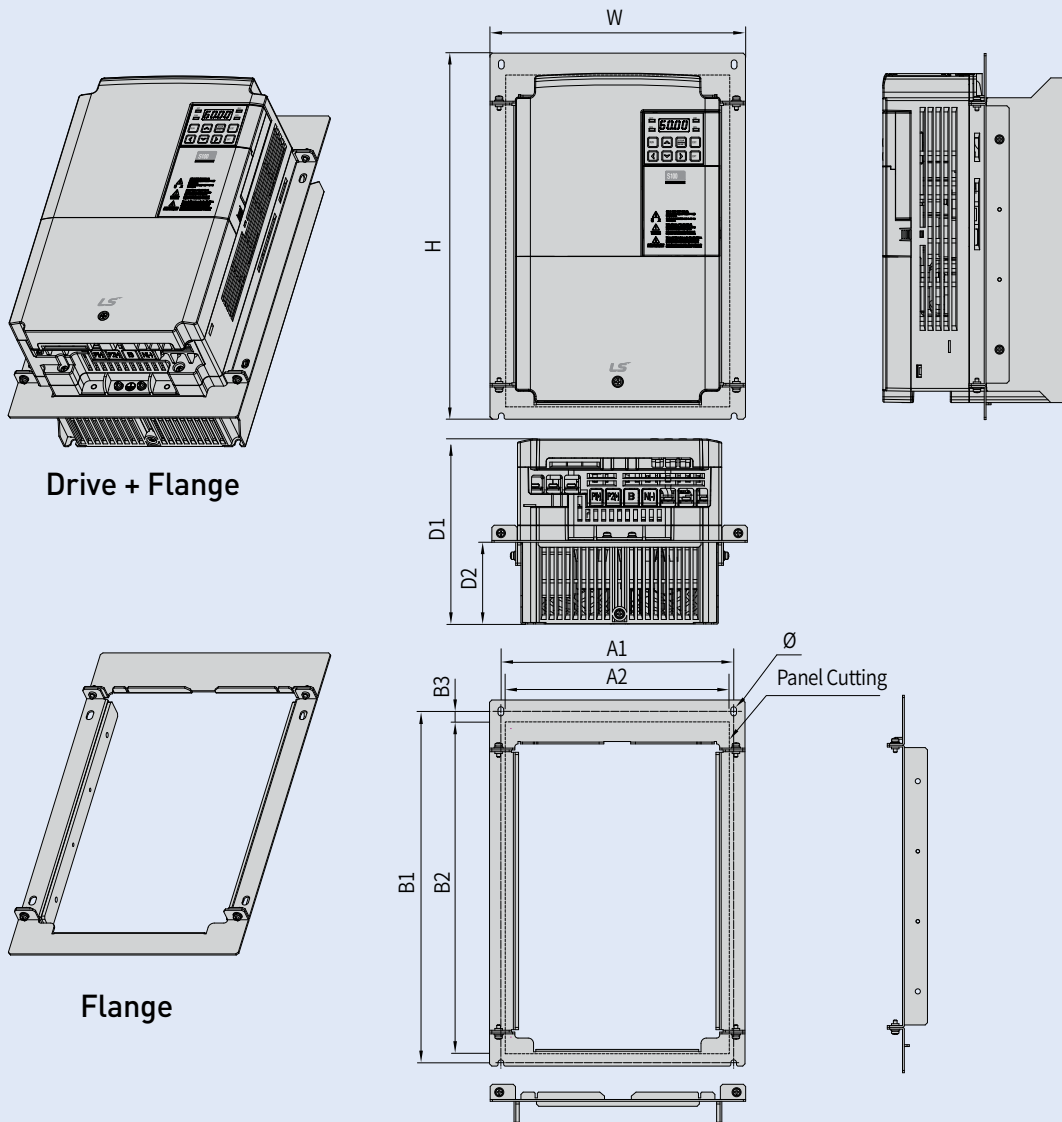

Unit : mm(Inches), kg

Drive Capacity	W	H	D1	D2	A1	A2	B1	B2	B3	Ø	Weight
LSLV0055S100-2	206 (8.11)	264.5 (10.41)	140 (5.51)	55.1 (2.17)	186 (7.32)	178 (7.01)	251.5 (9.90)	235 (9.25)	8.4 (0.33)	5 (0.20)	3.7
LSLV0055S100-4 ^{*1)}	206 (8.11)	264.5 (10.41)	140 (5.51)	55.1 (2.17)	186 (7.32)	178 (7.01)	251.5 (9.90)	235 (9.25)	8.4 (0.33)	5 (0.20)	3.7
LSLV0075S100-2	206 (8.11)	264.5 (10.41)	140 (5.51)	55.1 (2.17)	186 (7.32)	178 (7.01)	251.5 (9.90)	235 (9.25)	8.4 (0.33)	5 (0.20)	3.7
LSLV0075S100-4 ^{*1)}	206 (8.11)	264.5 (10.41)	140 (5.51)	55.1 (2.17)	186 (7.32)	178 (7.01)	251.5 (9.90)	235 (9.25)	8.4 (0.33)	5 (0.20)	3.7
LSLV0110S100-2	225.2 (8.87)	322.7 (12.71)	163 (6.42)	72.1 (2.84)	205.2 (8.09)	197.5 (7.78)	309.7 (12.19)	292.5 (11.52)	9.3 (0.37)	5 (0.20)	5.15
LSLV0110S100-4 ^{*1)}	225.2 (8.87)	322.7 (12.71)	163 (6.42)	72.1 (2.84)	205.2 (8.09)	197.5 (7.78)	309.7 (12.19)	292.5 (11.52)	9.3 (0.37)	5 (0.20)	5.15
LSLV0150S100-2	267 (10.51)	384.5 (15.14)	187 (7.36)	93.6 (3.69)	247 (9.72)	239 (9.41)	371.5 (14.63)	352 (13.86)	9.5 (0.37)	6 (0.24)	5.4
LSLV0150S100-4 ^{*1)}	225.2 (8.87)	322.7 (12.71)	163 (6.42)	72.1 (2.84)	205.2 (8.09)	197.5 (7.78)	309.7 (12.19)	292.5 (11.52)	9.3 (0.37)	5 (0.20)	5.15
LSLV0185S100-4 ^{*1)}	267 (10.51)	384.5 (15.14)	187 (7.36)	93.6 (3.69)	247 (9.72)	239 (9.41)	371.5 (14.63)	352 (13.86)	9.5 (0.37)	6 (0.24)	8.3
LSLV0220S100-4 ^{*1)}	267 (10.51)	384.5 (15.14)	187 (7.36)	93.6 (3.69)	247 (9.72)	239 (9.41)	371.5 (14.63)	352 (13.86)	9.5 (0.37)	6 (0.24)	8.3

*1) EMC filter built-in Class3

Flange Option

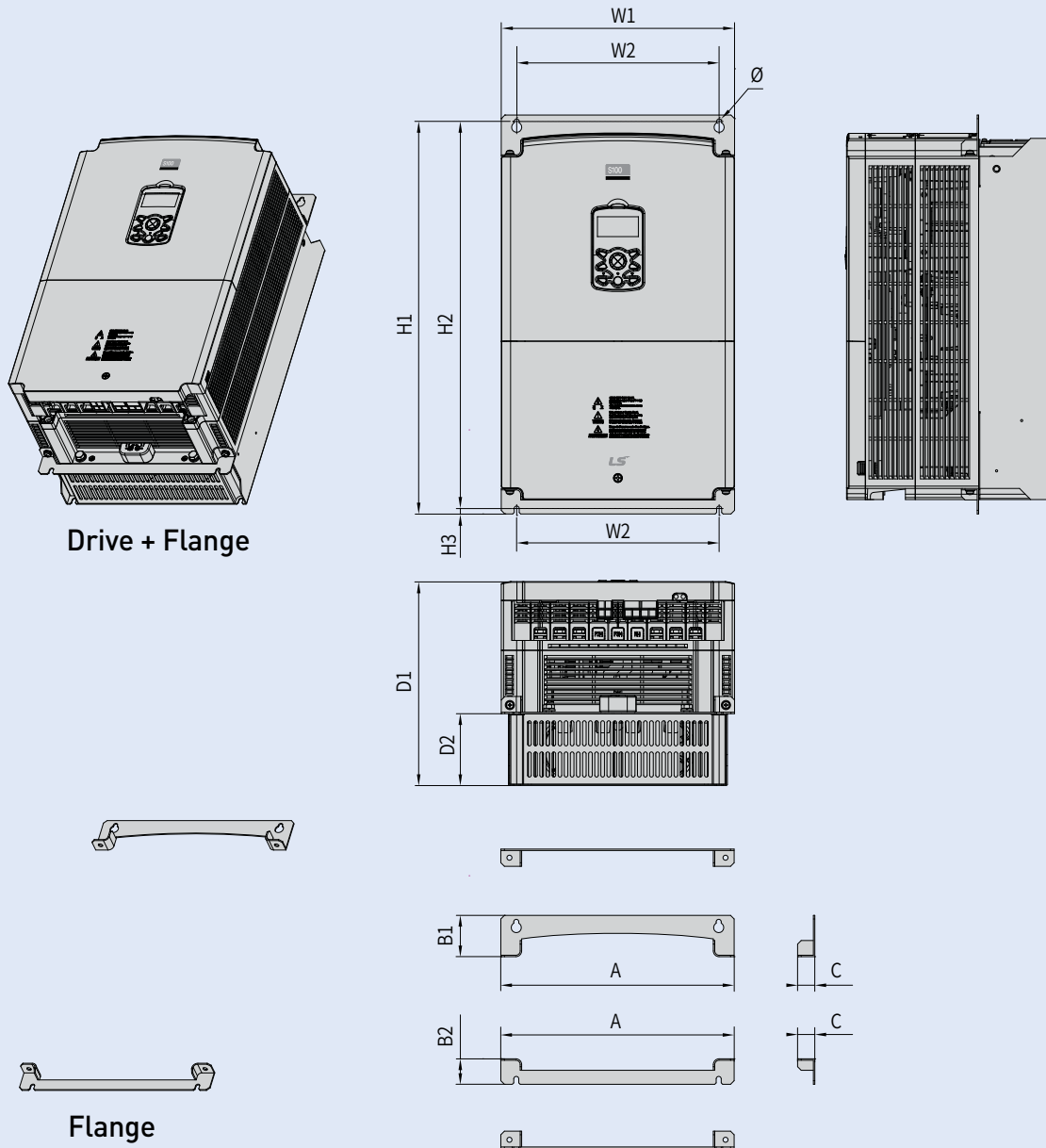

Unit : mm(Inches), kg

Drive Capacity	W1	W2	H1	H2	H3	D1	D2	A	B1	B2	C	Ø	Weight
LSLV0300S100-4 ¹⁾	275 (10.83)	232 (9.13)	495 (19.49)	478.5 (18.84)	7.5 (0.30)	284 (11.18)	100 (3.94)	275 (10.83)	55 (2.17)	35.5 (1.40)	24 (0.94)	7 (0.28)	26.4
LSLV0370S100-4 ¹⁾	325 (12.80)	282 (11.10)	555.5 (21.87)	539 (21.22)	7.5 (0.30)	284 (11.18)	100 (3.94)	325 (12.80)	57.5 (2.26)	35.5 (1.40)	24 (0.94)	7 (0.28)	35.4
LSLV0450S100-4 ¹⁾	325 (12.80)	282 (11.10)	555.5 (21.87)	539 (21.22)	7.5 (0.30)	284 (11.18)	100 (3.94)	325 (12.80)	57.5 (2.26)	35.5 (1.40)	24 (0.94)	7 (0.28)	35.4
LSLV0550S100-4 ¹⁾	325 (12.80)	275 (10.83)	605.5 (23.84)	587 (23.11)	9.5 (0.37)	309 (12.17)	131.6 (5.18)	325 (12.80)	68.5 (2.69)	46.5 (1.83)	24 (0.94)	9 (0.35)	43.5
LSLV0750S100-4 ¹⁾	325 (12.80)	275 (10.83)	605.5 (23.84)	587 (23.11)	9.5 (0.37)	309 (12.17)	131.6 (5.18)	325 (12.80)	68.5 (2.69)	46.5 (1.83)	24 (0.94)	9 (0.35)	43.5

*1) EMC filter built-in Class3

Scale: mm

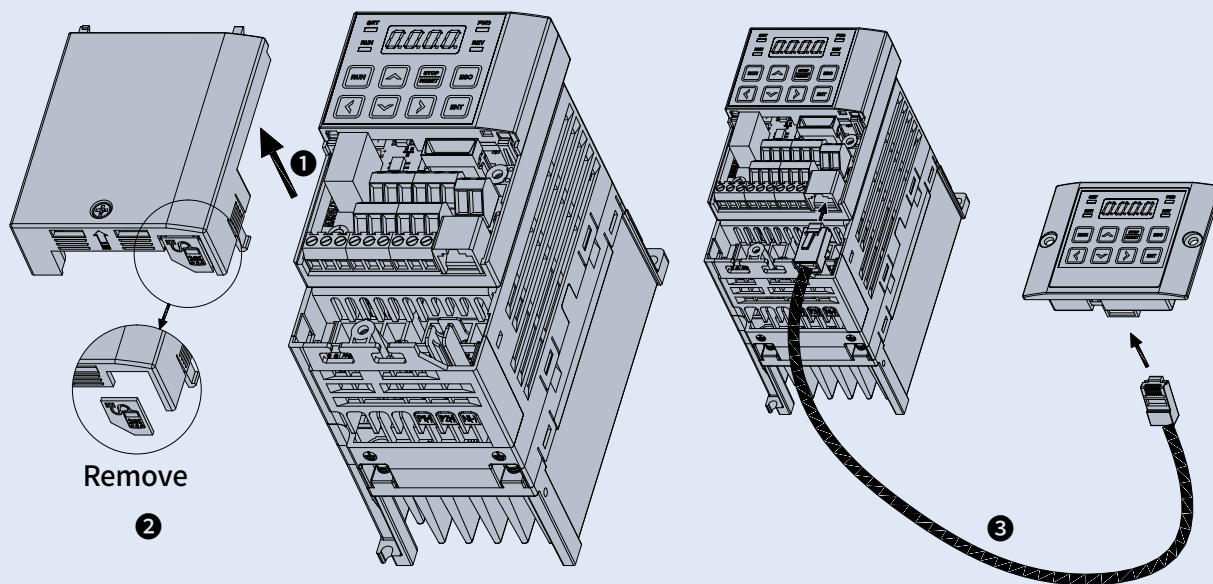
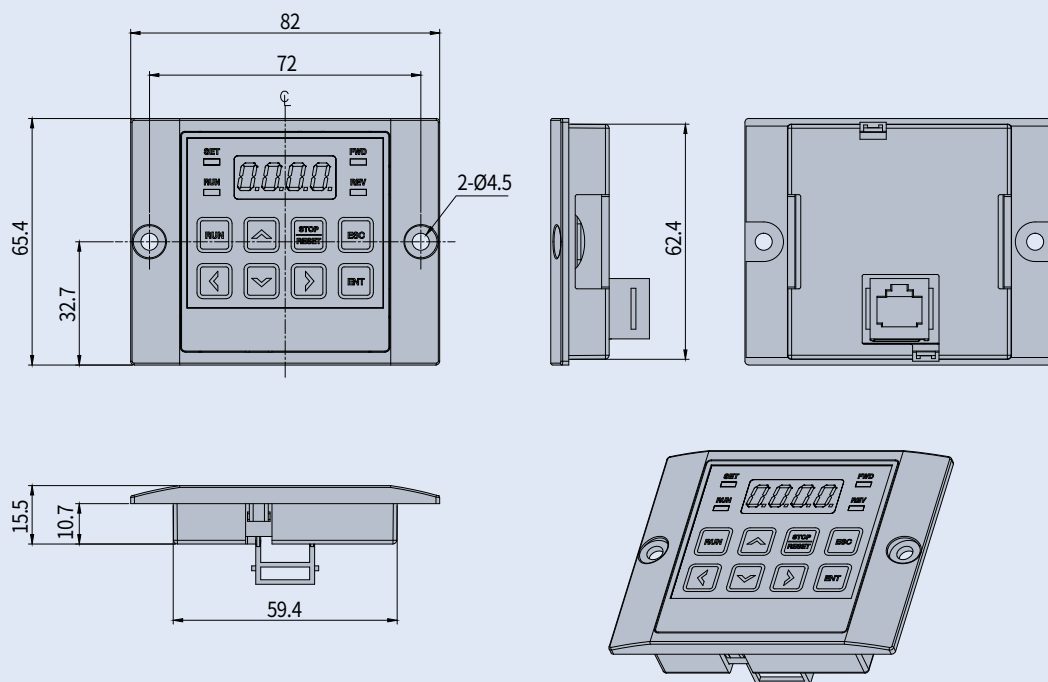

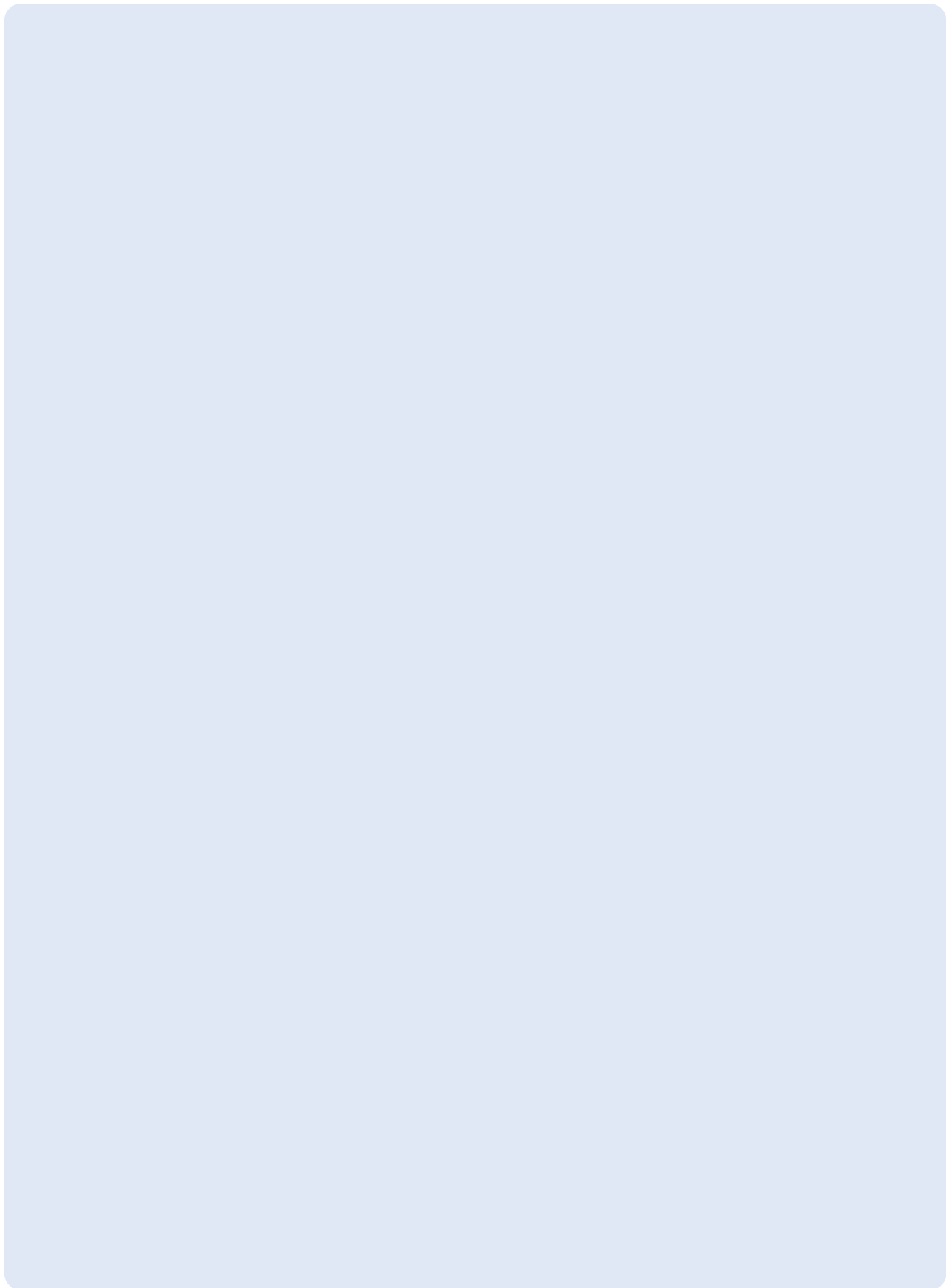

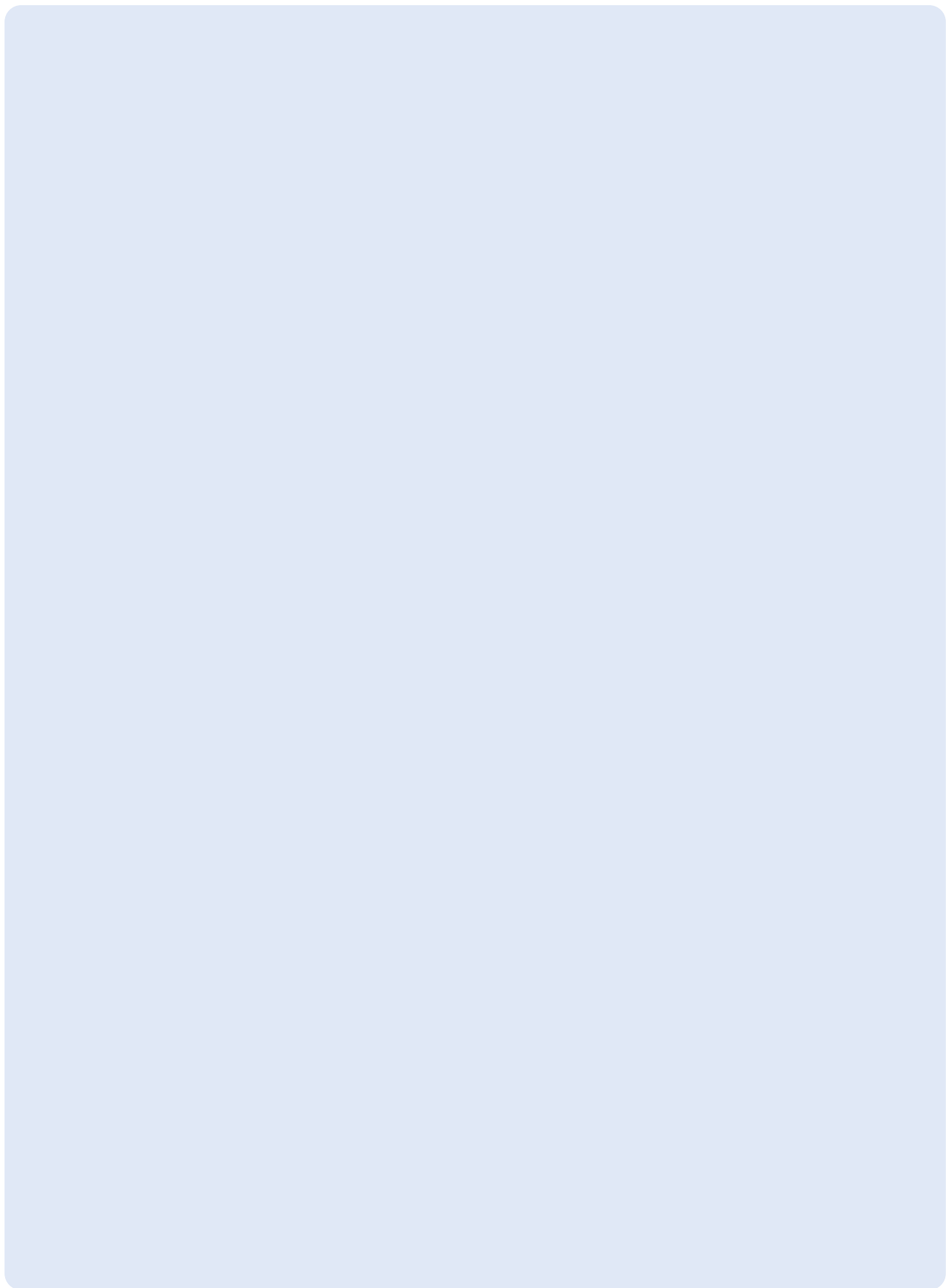



Safety Instructions

- For your safety, please read user's manual thoroughly before operating.
- Contact the nearest authorized service facility for examination, repair, or adjustment.
- Please contact qualified service technician when you need maintenance. Do not disassemble or repair by yourself!
- Any maintenance and inspection shall be performed by the personnel having expertise concerned.



- According to The WEEE Directive, please do not discard the device with your household waste.

LS ELECTRIC

www.ls-electric.com

■ Headquarter

LS-ro 127(Hogye-dong) Dongan-gu, Anyang-si, Gyeonggi-Do, 14119, Korea

■ Seoul Office

LS Yongsan Tower, 92, Hangang-daero, Yongsan-gu, Seoul, 04386, Korea
Tel: 82-2-2034-4644(Europe), 4982(USA), 4884(East Asia)
Fax: 82-2-2034-4588 E-mail: drivesales@ls-electric.com

■ Overseas Subsidiaries

- LS ELECTRIC Japan Co., Ltd. (Tokyo, Japan)
Tel: 81-3-6268-8241 E-Mail: japan@ls-electric.com
- LS ELECTRIC (Dalian) Co., Ltd. (Dalian, China)
Tel: 86-411-8730-6495 E-Mail: china.dalian@lselectric.com.cn
- LS ELECTRIC (Wuxi) Co., Ltd. (Wuxi, China)
Tel: 86-510-6851-6666 E-Mail: china.wuxi@lselectric.com.cn
- LS ELECTRIC Middle East FZE (Dubai, U.A.E.)
Tel: 971-4-886-5360 E-Mail: middleeast@ls-electric.com
- LS ELECTRIC Europe B.V. (Hoofddorp, Netherlands)
Tel: 31-20-654-1424 E-Mail: europartner@ls-electric.com
- LS ELECTRIC America Inc. (Chicago, USA)
Tel: 1-800-891-2941 E-Mail: sales.us@lselectricamerica.com
- LS ELECTRIC Türkiye Co., Ltd.
Tel: 90-212-806-1225 E-Mail: Türkiye@ls-electric.com

■ Overseas Branches

- LS ELECTRIC Tokyo Office (Japan)
Tel: 81-3-6268-8241 E-Mail: tokyo@ls-electric.com
- LS ELECTRIC Beijing Office (China)
Tel: 86-10-5095-1631 E-Mail: china.auto@lselectric.com.cn
- LS ELECTRIC Shanghai Office (China)
Tel: 86-21-5237-9977 E-Mail: china.auto@lselectric.com.cn
- LS ELECTRIC Guangzhou Office (China)
Tel: 86-20-3818-2883 E-Mail: china.auto@lselectric.com.cn
- LS ELECTRIC Chengdu Office (China)
Tel: 86-28-8670-3201 E-Mail: china.auto@lselectric.com.cn
- LS ELECTRIC Qingdao Office (China)
Tel: 86-532-8501-2065 E-Mail: china.auto@lselectric.com.cn
- LS ELECTRIC Nanjing Office (China)
Tel: 86-25-8467-0005 E-Mail: china.auto@lselectric.com.cn
- LS ELECTRIC Bangkok Office (Thailand)
Tel: 66-90-950-9683 E-Mail: thailand@ls-electric.com
- LS ELECTRIC Jakarta Office (Indonesia)
Tel: 62-21-2933-7614 E-Mail: indonesia@ls-electric.com
- LS ELECTRIC Moscow Office (Russia)
Tel: 7-499-682-6130 E-Mail: info@lselectric-ru.com
- LS ELECTRIC America Western Office (Irvine, USA)
Tel: 1-949-333-3140 E-Mail: america@ls-electric.com
- LS ELECTRIC Italy office (Italy)
Tel: 39-030-8081-833 E-Mail: italia@ls-electric.com