



INDUSTRIAL AUTOMATION

INDUSTRIAL AUTOMATION - 151390025EN - First Edition 2015/2016 - published on March 1st 2015
All figures, dimensions, weights and data are indicative.
For a detailed dimensioning please call Santerno pre-sales technical office.
This catalogue is subject to changes without prior notice. No liability shall be accepted for printing errors.

Giving energy more value ■

شماره تماس :
۰۵۱-۳۶۵۱۲۶۲۶
۰۵۱-۳۷۶۴۴۶۰۰

آدرس : مشهد، بلوار توس، بین توس ۷۳ و ۷۵
وبسایت : www.kalasanatisafaei.com

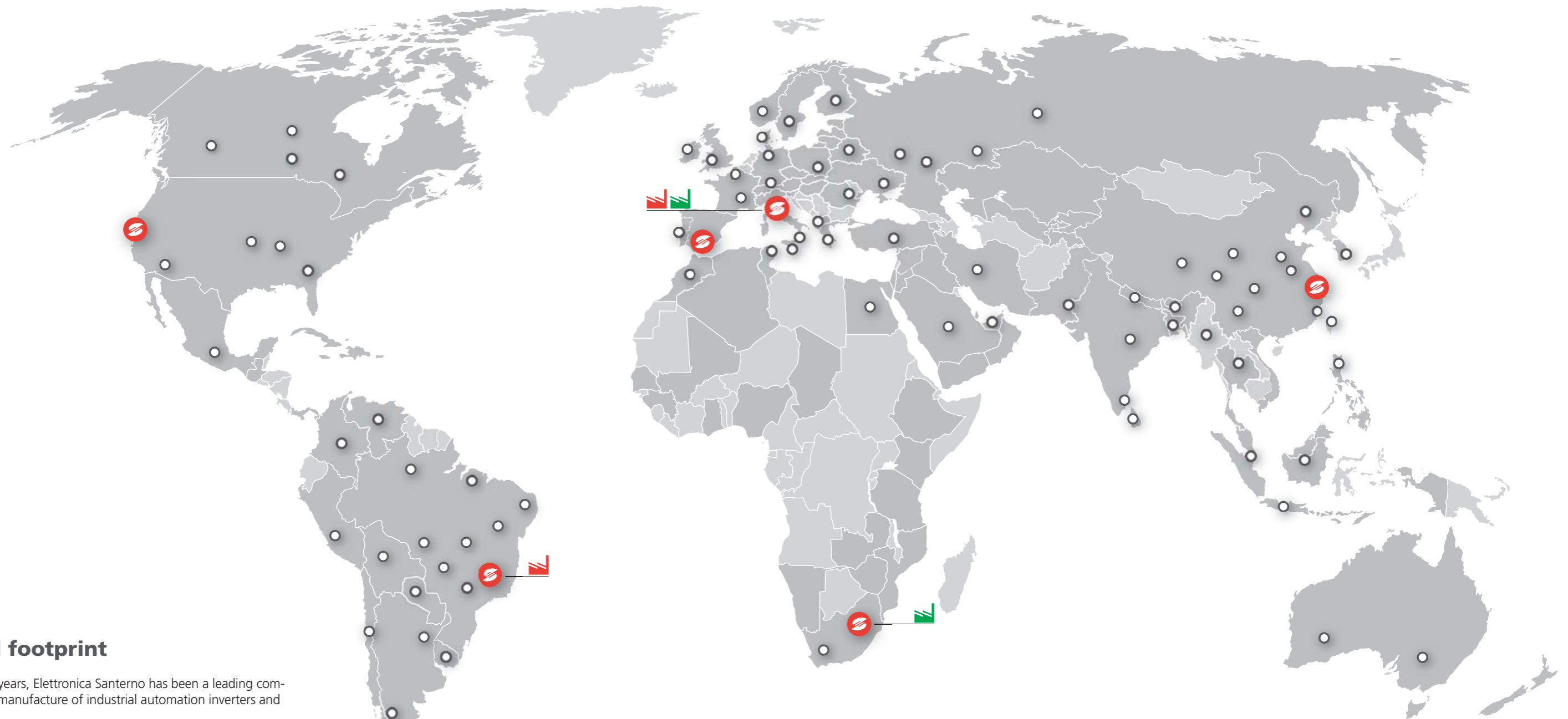

Global footprint

For over 40 years, Elettronica Santerno has been a leading company in the manufacture of industrial automation inverters and softstarters.

Based in Castel Guelfo, Italy, with branches and commercial offices in Brazil, Spain, USA, China and South Africa.

Santerno has a worldwide sales network of over 50 distributors also providing after-sales service.

LEGEND:

○ National distributors

⊖ Branches

⚡ Own assembly plants

⚡ Outsourcer's assembly plant

During the last 5 years Santerno inverters have been installed in over 100 countries worldwide.

Afghanistan	Chile	Germany	Jordan	Morocco	Portugal	South Africa	United Kingdom
Albania	China	Ghana	Kazakhstan	Namibia	Qatar	Spain	United Republic of Tanzania
Algeria	Colombia	Greece	Kenya	Netherlands	Republic of Korea	Sri Lanka	United States of America
Argentina	Cyprus	Guatemala	Kuwait	New Zealand	Republic of Moldova	Sweden	Uruguay
Armenia	Czech Republic	Guinea	Kyrgyzstan	Nigeria	Romania	Switzerland	Uzbekistan
Australia	Denmark	Hungary	Latvia	Norway	Russian Federation	Syrian Arab Republic	Venezuela
Austria	Dominican Republic	India	Lesotho	Oman	San Marino	Tajikistan	Viet Nam
Bangladesh	Ecuador	Indonesia	Liechtenstein	Pakistan	Saudi Arabia	Taiwan	Taiwan
Belarus	Egypt	Iran	Lithuania	Panama	Senegal	Thailand	Tajikistan
Belgium	Estonia	Iraq	Malaysia	Paraguay	Serbia	Tunisia	Zambia
Bhutan	Ethiopia	Ireland	Mali	Peru	Singapore	Turkey	
Brazil	France	Israel	Malta	Philippines	Slovakia	Ukraine	
Canada	Gambia	Italy	Mexico	Poland	Slovenia	United Arab Emirates	



Table of contents

Santerno global footprint	2
SINUS N	6
SINUS M	8
SINUS PENTA 2T/4T	16
SINUS PENTA 5T/6T	30
SINUS PENTA IN CABINET	44
SINUS PENTA BOX IP54	52
Inductors	54
Braking units and resistors	68
Optional boards	90
SINUS K - Lift software	100
ASAC0/ASAC1 - Soft starters	104
ASAB - Soft starters	108
ASAMV - Soft starters	116
DCREG2 - DCREG4 - AC/DC digital converters	122
CU400 clamping unit for DCREG4	128
MJ-MA - electrical motors	130
INDUSTRIAL SECTORS AND APPLICATIONS	134
Santerno Subsidiaries and Distributors	150



Sensorless vector control or V/F inverter for AC three-phase induction motors from 0.4 kW to 3.0 kW

- 200-230Vac single-phase power supply (three-phase output)
- Full compatibility with the "REMOTE DRIVE" software for remote control

Technical features & highlights

- Power range 0.4~3kW
- 2 control modes: V/F and Sensorless Vector Control
- Built-in potentiometer
- Start/stop keypad
- IP20 enclosure
- Overload capability 150% for 1 min. 200% for 0.5 sec.
- Maximum output frequency 400Hz
- Motor auto-tuning for optimum performance
- Anti-stalling and antitrip algorithm
- Adjustable carrier 1-15kHz
- Automatic and manual torque boost
- JOG function
- Speed search
- PID function
- "S" ramps
- 8 speed sets
- 3 frequency jumps (skip)
- 5 NPN PNP programmable digital inputs
- 2 analog inputs 0-10Vdc and 4-20mA
- 1 multi-function open-collector output
- 1 multi-function relay output
- 1 analog multi-function output 0-10Vdc
- INTEGRATED INPUT FILTERS, EMC EN61800-3, 2nd edition, FIRST ENVIRONMENT Category C1, EN55011 gr.1 cl. B, for residential and industrial environments

Options

- Output ferrite ring filters
- Analog converter V/I (0-10/4-20mA)
- Relay for open collector output
- "Remote Drive" software
- Converter for MODBUS/Profibus DP-CanBus-Device Net etc.
- RS485/USB converter

Product selection chart

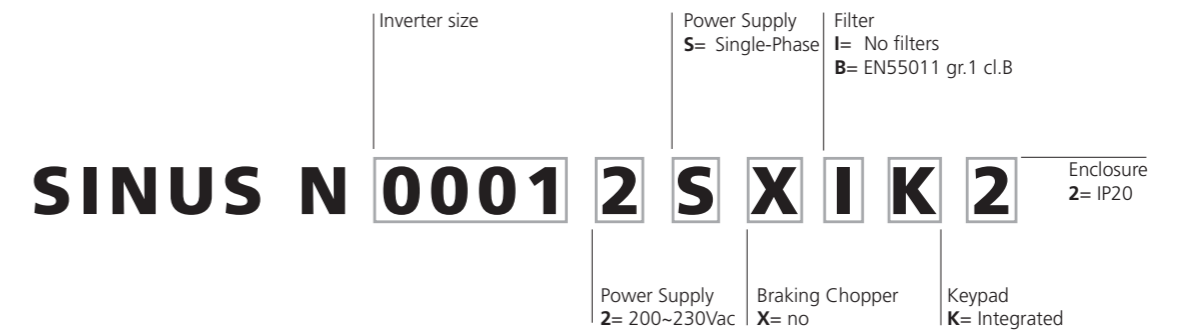

Model	Input Voltage	Motor power		Output Inom.	Output Imax 150% (60s)	Ipeak Output 200% (0.5s)	Dimensions	Weight
	Vac	kW	HP	A	A	A	WxHxD (mm)	kg
SINUS N 0001 2S XIK2	1 φ 200 ~ 230V	0.4	0.5	2.5	3.7	5	79x143x143	0.87
SINUS N 0002 2S XIK2	1 φ 200 ~ 230V	0.75-1.1	1-1.5	5	7.5	10	79x143x143	0.89
SINUS N 0003 2S XIK2	1 φ 200 ~ 230V	1.5-1.8	2-2.5	8	12	16	156x143x143	1.79
SINUS N 0005 2S XIK2	1 φ 200 ~ 230V	2.2-3	3-4	12	18	24	156x143x143	1.85
SINUS N 0001 2S XBK2	1 φ 200 ~ 230V	0.4	0.5	2.5	3.7	5	79x143x143	0.95
SINUS N 0002 2S XBK2	1 φ 200 ~ 230V	0.75-1.1	1-1.5	5	7.5	10	79x143x143	0.97
SINUS N 0003 2S XBK2	1 φ 200 ~ 230V	1.5-1.8	2-2.5	8	12	16	156x143x143	1.94
SINUS N 0005 2S XBK2	1 φ 200 ~ 230V	2.2-3	3-4	12	18	24	156x143x143	2

Technical features & highlights

- Power ranges:
 0.37~22 kW 200-230Vac, 3phase
 0.37~22 kW 380-480Vac, 3phase
- IP20 enclosure
- Built-in braking unit
- Possibility of connecting a DC choke in sizes 11kW to 22kW
- 2 Control modes: V/F and Sensorless Vector Control
- RS485 serial port with MODBUS RTU protocol
- Removable smart keyboard
- Overload 150% of In for 60 sec
- Overload 200% for short time span
- Maximum torque 180% Tn
- Maximum output frequency 400Hz
- Anti-stalling and overvoltage trip prevention
- 8 speed sets
- 3 frequency jumps (skip)
- 8 NPN PNP programmable digital inputs
- 2 analog inputs 0-10Vdc and 4-20mA
- 1 programmable open-collector output
- 1 programmable relay output
- 1 analog output 0-10Vdc
- Adjustable carrier 1-15kHz
- Automatic and manual torque boost
- Speed search
- PID function
- "S" ramps
- Fire Mode function
- Draw function
- UP-DOWN function
- 2-phase PWM
- KEB (Kinetic Energy Buffering)
- External brake control
- INTEGRATED INPUT FILTERS, EMC EN61800-3, 2nd edition, FIRST ENVIRONMENT Category C1, EN55011 gr.1 cl. B, for residential and industrial environments

Options

- Remote keyboard operation kit (3 metres).
- EMC foot print filters EN 55011 Cl. B, public utility, FIRST ENVIRONMENT.
- Braking resistors.
- Relay for open-collector output.
- "Remote Drive" software.
- Converter for MODBUS/Profibus DP-CanBus-Device Net etc.
- RS485/USB converter



Sensorless vector control or V/F inverter for AC three-phase induction motors from 0.37 kW to 22.0 kW

- 200-480Vac power supply (three-phase input, three-phase output)
- Fully compatibility with Easy Harmonics, tool for the calculation of current harmonics
- Full compatibility with the "REMOTE DRIVE" software for remote control

Product selection chart

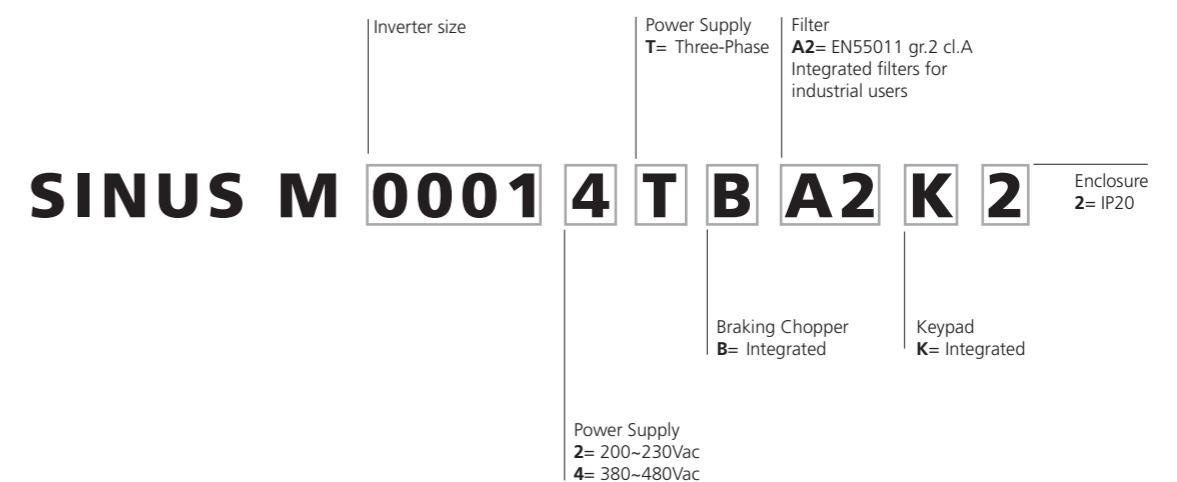

SINUS M



Model	Input Voltage	Motor power						Output Inom.	Imax. output 150% (60s)	Output Ipeak 200% (0.5s)	Dimensions	Weight
		200-230 Vac		380-415 Vac		440-460 Vac						
		Vac	kW	HP	kW	HP	kW					
SINUS M 0001 2T BA2K2	3 φ 200 ~ 230V	0.4	0.5	-	-	-	-	2.5	3.8	5	70x128x130	0.76
SINUS M 0002 2T BA2K2	3 φ 200 ~ 230V	0.75-1.1	1-1.5	-	-	-	-	5	7.5	10	70x128x130	0.77
SINUS M 0003 2T BA2K2	3 φ 200 ~ 230V	1.5-1.8	2-2.5	-	-	-	-	8	12	16	100x128x130	1.12
SINUS M 0005 2T BA2K2	3 φ 200 ~ 230V	2.2-3	3-4	-	-	-	-	12	18	24	140x128x155	1.84
SINUS M 0007 2T BA2K2	3 φ 200 ~ 230V	4.0-4.5	5.5-6	-	-	-	-	17	25.5	34	140x128x155	1.89
SINUS M 0011 2T BA2K2	3 φ 200 ~ 230V	5.5	7.5	-	-	-	-	24	36	48	180x220x170	3.66
SINUS M 0014 2T BA2K2	3 φ 200 ~ 230V	7.5-9.2	10-12.5	-	-	-	-	32	48	64	180x220x170	3.66
SINUS M 0017 2T BA2K2	3 φ 200 ~ 230V	11	15	-	-	-	-	46	69	92	235x320x189.5	9
SINUS M 0020 2T BA2K2	3 φ 200 ~ 230V	15	20	-	-	-	-	60	90	120	235x320x189.5	9
SINUS M 0025 2T BA2K2	3 φ 200 ~ 230V	18.5	25	-	-	-	-	74	111	148	260x410x208.5	13.3
SINUS M 0030 2T BA2K2	3 φ 200 ~ 230V	22	30	-	-	-	-	88	132	176	260x410x208.5	13.3
SINUS M 0001 4T BA2K2	3 φ 380 ~ 480V	-	-	0.4	0.5	0.4	0.5	1.25	1.87	2.5	70x128x130	0.76
SINUS M 0002 4T BA2K2	3 φ 380 ~ 480V	-	-	0.75-0.9	1-1.25	0.75-1.1	1-1.5	2.5	3.75	5	70x128x130	0.77
SINUS M 0003 4T BA2K2	3 φ 380 ~ 480V	-	-	1.5	2	1.5-1.8	2-3	4	6	8	100x128x130	1.12
SINUS M 0005 4T BA2K2	3 φ 380 ~ 480V	-	-	2.2	3	2.2-3	3-4	6	9	12	140x128x155	1.84
SINUS M 0007 4T BA2K2	3 φ 380 ~ 480V	-	-	4-4.5	5.5-6	4-4.5	5.5-6	9	13.5	18	140x128x155	1.89
SINUS M 0011 4T BA2K2	3 φ 380 ~ 480V	-	-	5.5	7.5	5.5	7.5	12	18	24	180x220x170	3.66
SINUS M 0014 4T BA2K2	3 φ 380 ~ 480V	-	-	7.5	10	7.5-9.2	10-12.5	16	24	32	180x220x170	3.66
SINUS M 0017 4T BA2K2	3 φ 380 ~ 480V	-	-	11	15	11	15	24	36	48	235x320x189.5	9
SINUS M 0020 4T BA2K2	3 φ 380 ~ 480V	-	-	15	20	15	20	30	45	60	235x320x189.5	9
SINUS M 0025 4T BA2K2	3 φ 380 ~ 480V	-	-	18.5	25	22	30	39	58.5	78	260x410x208.5	13.3
SINUS M 0030 4T BA2K2	3 φ 380 ~ 480V	-	-	22	30	22	30	45	67.5	90	260x410x208.5	13.3



SINUS PENTA

Premium Drives for all applications!

Full range of premium drives for AC three-phase induction and synchronous motors

5 different control functions: V/F, Sensorless VTC,FOC, SYN, regenerative.

Available in IP00, IP20, IP54 enclosures.

Complete range of inductors, filters, braking unit and resistors.

Complete range of optional boards: speed sensors, communications,

I/O expansion, field bus, dataloggers



marine applications
special-purpose product
line available



The SINUS PENTA drives have one common part number coding. Refer to this coding to select the specific model and options required for your application. The part number starts with "SINUS P" that identifies the SINUS PENTA family, the following 4 digit number identifies the inverter model. The part number details are given below.

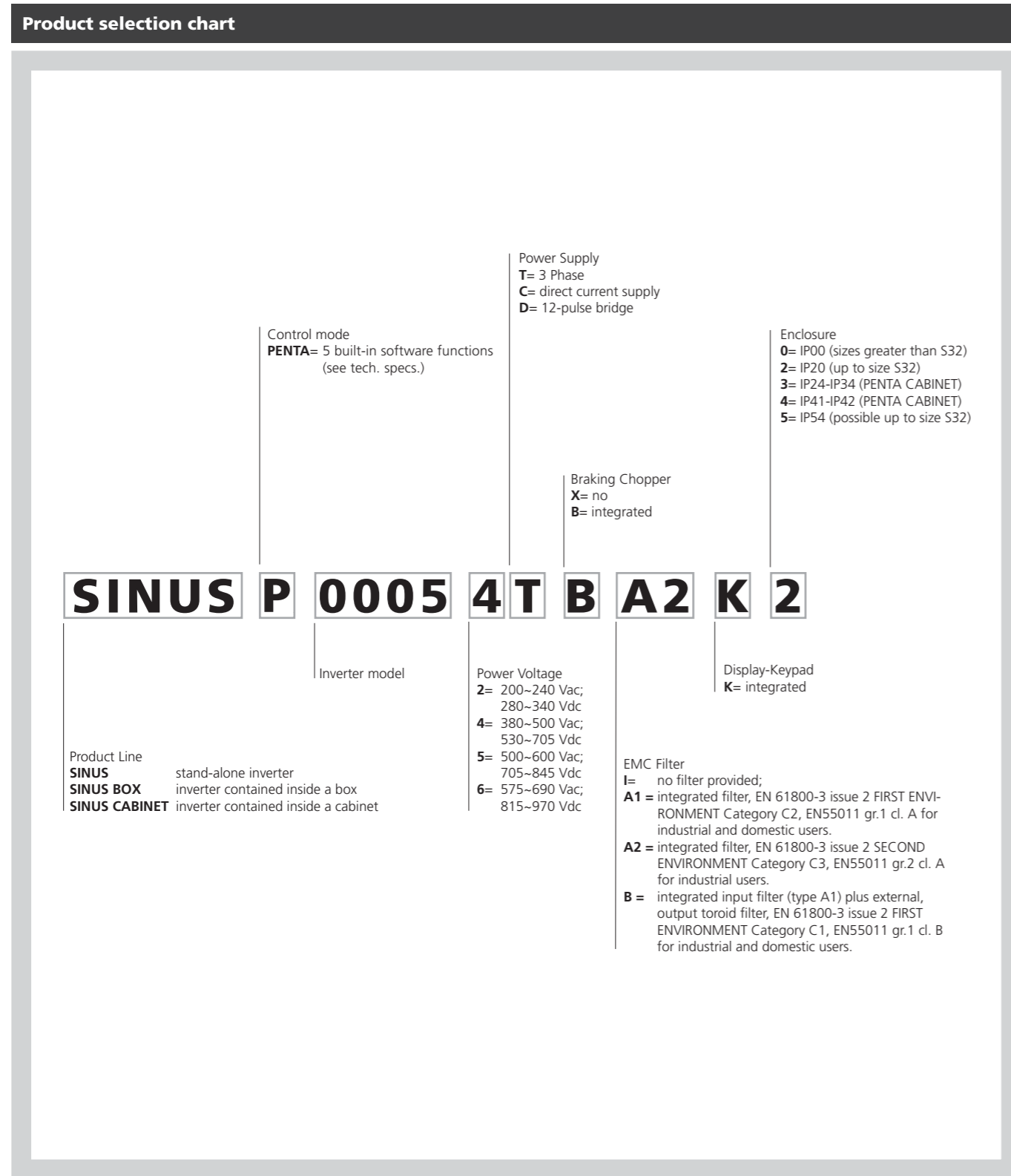

NOTE: Not all combinations are possible.



Overload Choice

Applications	Overload			
	Light	Standard	Heavy	Strong
Agitator		•		
Atomizer	•			
Axis control			•	•
Ball mill			•	
Bandsaw	•			
Bore pumps			•	
Bottle washer	•			
Calenders		•	•	
Centrifugal damped fan	•			
Centrifugal pumps		•		
Centrifuge		•		
Chipper		•		
Circular saw		•		
Conveyor belt		•	•	
Conveyor roller		•		
Conveyor screw			•	
Crusher cone		•		
Crusher jaw			•	
Crusher rotary		•		
Crusher vertical impact		•		
Damped axial fan	•			
Debarker		•		
Drawplates		•	•	
Drills			•	•
Dryer		•	•	
Dust collector	•			
Edger		•		
Elevators			•	•
Extruders	•			
Forming machines		•	•	
Grinder	•			
Hammer Mill		•		
High pressure fan	•			

Applications	Overload			
	Light	Standard	Heavy	Strong
Hoists and cranes' translation			•	
Hydraulic power pack		•		
Hydraulic power pack injection moulding machines		•		
Industrial washers			•	
Loaded piston compressor			•	
Looms		•	•	
Mechanical presses		•	•	
Mill		•		
Mixer	•			
Palletiser		•	•	
Planers		•		
Positive displacement pumps			•	
Pulper		•		
Roller mill		•		
Rolling Plants			•	
Rotary table		•		
Sander		•	•	
Screw compressor, loaded		•		
Screw compressor, unloaded	•			
Screw injection moulding machines		•	•	
Separator	•			
Shears		•	•	
Shredder	•			
Slicer	•			
Slurry pumps		•		
Tumbler	•			
Twister/Spinner			•	•
Undamped axial fan	•			
Undamped centrifugal fan	•			
Unloaded piston compressor		•		
Vibrating screen	•			
Winding/unwinding		•	•	



3 YEARS WARRANTY

SUPPLY VOLTAGE
2T = 200-240 VAC
4T = 380-500 VAC

5-function drives 1.3kW to 900kW for:
- Three-phase asynchronous motor control
- Three-phase synchronous motor control
- Regeneration into the grid

- Wide power supply voltage range, 200÷500 Vac
- DC power supply range 280÷705 Vdc
- Input frequency 50 - 60 Hz
- Available in cabinet up to 2100 kW
- Enclosure IP00, IP20, IP54
- Full compatibility with the "REMOTE DRIVE" software for remote control

Technical Highlights

One product, 5 integrated functions

- **IFD** (Inverter Frequency Drive): vector modulation function for general-purpose applications (V/F pattern).
- **VTC** (Vector Torque Control): sensorless vector function for high-torque demanding applications.
- **FOC** (Field Oriented Control): vector function with encoder for high torque precision and wide speed range.
- **SYN** (Synchronous): vector function for brushless synchronous motors with permanent magnets, high torque precision joined to high energy efficiency level.
- **RGN** (Regenerative): sinusoidal power factor $\cos\Phi=1$, AC/DC feeder function for direct supply of a series of drives.
- Extremely compact dimensions: one of the best current density [A/m³] in the market!
- Widest range of STANDARD I/O.
- Most encoder input directly to control board, no option board required for FOC control.
- Open loop speed precision: $\pm 0.5\%$ of max. speed. Closed loop (with an encoder) speed precision: $< 0.01\%$ of max. speed.
- Intelligent cooling system. Through-Hole mounting, segregation of forced air flow channels.
- Integrated braking chopper up to S30 at 100% nominal current.
- Programmable logic blocks.
- Regulation of output frequency from 0 to 1000Hz (depending on models).
- Lower motor noise with random modulation and carrier frequency up to 16kHz (depending on models).
- Integrated EMC filters on the full range in compliance with EN61800-3 2nd ed.
- INTEGRATED INPUT FILTERS, EMC EN61800-3, 2nd edition, FIRST ENVIRONMENT Category C1, EN55011 gr.1 cl. B, for residential and industrial environments
- STO (Safe Torque Off) Function in compliance with EN 61800-5-2 SIL 3, EN ISO 13849 PL d.

Technical features

SINUS PENTA inverters fit any application thanks to their advanced features, among which: vector modulation; power control with the latest IGBTs; high immunity to radio interference; high overload capability.

- Easy commissioning with preset parameters for the most common applications.
- Operating parameters saved to removable keypad or PC and possibility of parameter transfer to multiple inverters.
- Control panel with 12 keys and large back-lit LCD.
- Automatic calibration for motor parameters tuning.
- Programmable multiple acceleration and deceleration ramps. Programmable S ramps.
- Automatic DC braking.
- Motor PTC thermal probe control. Integrated motor thermal protection.
- In case of power failure, total control of the motor, down to 0 RPM.
- Master-slave function for the operation of several motors connected to the same drive shaft (VTC and FOC).
- 200% max torque.
- PID Function / Second PID Function / 2-zone PID.
- Skip frequency.
- Integrated digital potentiometer. Integrated multifunctional tester.
- Fire Mode function available.
- Trip Log.
- STANDARD I/Os:
 - Encoder feedback
 - 8 programmable inputs and MPL logic
 - 3 programmable analog inputs 0-10 Vdc, 0(4)-20 mA, PTC
 - 4 programmable digital output (2 relays with exchange contact, 1 open-collector, 1 Push-Pull)
 - Auxiliary input frequency 5,000-65,000 Hz, Auxiliary output frequency 5,000-65,000 Hz
 - 3 programmable analog outputs 0-10 Vdc, 0(4)-20 mA.
- Auxiliary output voltage 24 Vdc, 10 Vdc.
- Serial communications RS485 with MODBUS RTU protocol up to 38.400 Baud.

Special configurations

- 12-pulse bridge: starting from the S65 size, it is possible to supply the drive on 12-pulse bridge configuration.
- Optional boards for Fieldbus communication, Encoder or Resolver interface, Data loggers, RTC, I/O expansion.
- Custom execution in box or cabinets with input and/or DC and/or output inductors, circuit breakers, AFE sensors and switch.

SINUS PENTA 2T/4T



Technical data

Connected Motor power range/voltage range

1.5~260kW	200÷240Vac	3phase
2.2~710kW	380÷415Vac	3phase
3~800kW	440÷460Vac	3phase
3.7~900kW	480÷500Vac	3phase

Mains Vac supply voltage and frequency

2T	200÷240 Vac,	3phase,	-15% +10%	50÷60Hz
4T	380÷500 Vac,	3phase,	-15% +10%	50÷60Hz

DC supply voltage

2T	280÷340 Vdc
4T	530÷705 Vdc

Overvoltage category

III (refer to EN 61800-5-1)

Degree of protection/size

IP20 from Size S05 to Size S30,
IP00 from Size S41 to Size S65,
IP54 from Size S05 to Size S30

Ambient temperature

- 10°C to 55°C with no derating (or 2%/°C over 40°C based on the inverter model and the application category)

Storage temperature

-25 ÷ +70°C

Humidity

5 ÷ 95% (non condensing)

Altitude

Standard max. altitude 2000 m a.s.l
(2000 m ÷ 4000 m, on request)
Above 1000 m, derate 1%/100 m.

Vibrations

Lower than 9.8 m/sec² (= 1.0G)

Operating atmospheric pressure

86 ÷ 106 kPa

Cooling system

Forced air-cooling



Dimensions and weight IP20 - IP00 models

Size	W (mm)	H (mm)	D (mm)	Weight (kg)
S05	170	340	175	7
S12	215	401	225	12.5
S15	225	466	331	22.5
S20	279	610	332	36
S30	302	748	421	51
S41	500	882	409	121
S51	578	882	409	141
S60	890	1310	530	260
S65	980	1400	560	440

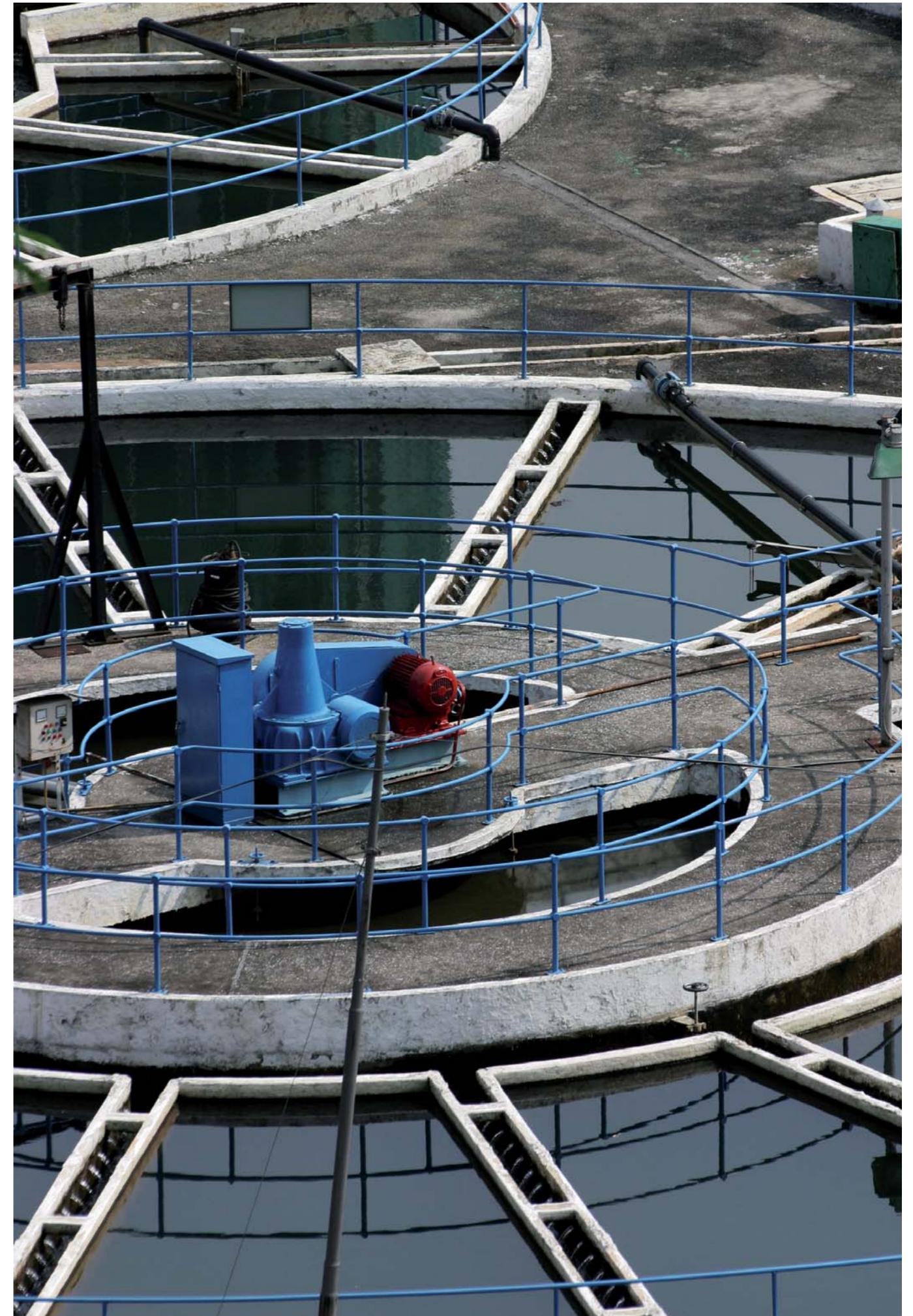

SINUS PENTA 2T/4T



LIGHT OVERLOAD UP TO 120% (120s) OR UP TO 144% (3s)

Power supply up to 500 Vac

Sinus Penta Model	2T			4T									Inom	Imax	Ipeak (3s)
	200-240 Vac			380-415 Vac			440-460 Vac			480-500 Vac					
	kW	HP	A	kW	HP	A	kW	HP	A	kW	HP	A			
Size S05															
SINUS PENTA 0005	-	-	-	4.5	6	9	5.5	7.5	9.7	6.5	9	10.2	10.5	11.5	14
SINUS PENTA 0007	3	4	11.2	5.5	7.5	11.2	7.5	10	12.5	7.5	10	11.8	12.5	13.5	16
SINUS PENTA 0008	3.7	5	13.2	-	-	-	-	-	-	-	-	-	15	16	19
SINUS PENTA 0009	-	-	-	7.5	10	14.5	9.2	12.5	16	9.2	12.5	14.3	16.5	17.5	19
SINUS PENTA 0010	4	5.5	14.6	-	-	-	-	-	-	-	-	-	17	19	23
SINUS PENTA 0011	-	-	-	7.5	10	14.8	9.2	12.5	16	11	15	16.5	16.5	21	25
SINUS PENTA 0013	4.5	6	15.7	-	-	-	-	-	-	-	-	-	19	21	25
SINUS PENTA 0014	-	-	-	7.5	10	14.8	9.2	12.5	16	11	15	16.5	16.5	25	30
SINUS PENTA 0015	5.5	7.5	19.5	-	-	-	-	-	-	-	-	-	23	25	30
SINUS PENTA 0016	7.5	10	25.7	-	-	-	-	-	-	-	-	-	27	30	36
SINUS PENTA 0020 ¹⁾	9.2	12.5	30	-	-	-	-	-	-	-	-	-	30	36	43
Size S12															
SINUS PENTA 0016	-	-	-	11	15	21	15	20	25	15	20	23.2	27	30	36
SINUS PENTA 0017	-	-	-	15	20	29	18.5	25	30	18.5	25	28	30	32	37
SINUS PENTA 0020	-	-	-	15	20	29	18.5	25	30	18.5	25	28	30	36	43
SINUS PENTA 0023	11	15	36	-	-	-	-	-	-	-	-	-	38	42	51
SINUS PENTA 0025	-	-	-	22	30	41	22	30	36	22	30	33	41	48	58
SINUS PENTA 0030	-	-	-	22	30	41	22	30	36	25	35	37	41	56	67
SINUS PENTA 0033	15	20	50	-	-	-	-	-	-	-	-	-	51	56	68
SINUS PENTA 0034	-	-	-	30	40	55	30	40	48	37	50	53	57	63	76
SINUS PENTA 0036	-	-	-	30	40	55	37	50	58	37	50	53	60	72	86
SINUS PENTA 0037	18.5	25	61	-	-	-	-	-	-	-	-	-	65	72	83
Size S15															
SINUS PENTA 0040	22	30	71	37	50	67	45	60	70	50	70	70	72	80	88
SINUS PENTA 0049	25	35	80	45	60	80	50	65	75	55	75	78	80	96	115
Size S20															
SINUS PENTA 0060	28	38	88	50	70	87	55	75	85	65	90	88	88	112	134
SINUS PENTA 0067	30	40	96	55	75	98	65	90	100	75	100	103	103	118	142
SINUS PENTA 0074	37	50	117	65	90	114	75	100	116	85	115	120	120	144	173
SINUS PENTA 0086	45	60	135	75	100	133	90	125	135	90	125	127	135	155	186
Size S30															
SINUS PENTA 0113	55	75	170	100	135	180	110	150	166	132	180	180	180	200	240
SINUS PENTA 0129	65	90	195	110	150	191	125	170	192	140	190	195	195	215	258
SINUS PENTA 0150	70	95	213	120	165	212	132	180	198	150	200	211	215	270	324
SINUS PENTA 0162	75	100	231	132	180	228	150	200	230	175	238	240	240	290	324
Inverter power supply	200-240 Vac; 280-340 Vdc			380-500 Vac; 530-705 Vdc											

1) unavailable model as IP54 - 2) Cabinet version only available on demand - 3) input reactor and output reactor required.
 Key Inom= inverter nominal current • Imax= inverter maximum current for 120sec every 20min. up to S30 and 60sec. Every 10min. >=S41 • Ipeak= inverter maximum current for 3sec

SINUS PENTA 2T/4T



LIGHT OVERLOAD UP TO 120% (120s) OR UP TO 144% (3s)

Power supply up to 500 Vac

Sinus Penta Model	2T			4T									Inom	Imax	Ipeak (3s)
	200-240 Vac			380-415 Vac			440-460 Vac			480-500 Vac					
	kW	HP	A	kW	HP	A	kW	HP	A	kW	HP	A			
Size S41															
SINUS PENTA 0180	90	125	277	160	220	273	200	270	297	220	300	300	300	340	408
SINUS PENTA 0202	110	150	332	200	270	341	220	300	326	250	340	337	345	420	504
SINUS PENTA 0217	120	165	375	220	300	375	250	340	366	260	350	359	375	460	552
SINUS PENTA 0260	132	180	390	250	340	421	280	380	410	300	410	418	425	560	672
Size S51															
SINUS PENTA 0313	160	220	475	280	380	480	315	430	459	355	485	471	480	600	720
SINUS PENTA 0367	185	250	550	315	430	528	375	510	540	400	550	544	550	680	792
SINUS PENTA 0402	200	270	593	400	550	680	450	610	665	500	680	673	680	850	1020
Size S60															
SINUS PENTA 0457	250	340	732	400	550	680	450	610	665	500	680	673	720	880	1056
SINUS PENTA 0524	260	350	780	450	610	765	500	680	731	560	760	751	800	960	1152
Size S60P															
SINUS PENTA 0598P	-	-	-	500	680	841	560	760	817	630	860	864	900	1100	1152
Size S65³⁾															
SINUS PENTA 0598	-	-	-	500	680	841	560	760	817	630	860	864	900	1100	1320
SINUS PENTA 0748	-	-	-	560	760	939	630	860	939	710	970	960	1000	1300	1560
SINUS PENTA 0831	-	-	-	710	970	1200	800	1090	1160	900	1230	1184	1200	1440	1728
Size S75³⁾															
SINUS PENTA 0964	-	-	-	900	1230	1480	1000	1360	1431	1100	1500	1480	1480	1780	2136
SINUS PENTA 1130	-	-	-	1000	1360	1646	1170	1600	1700	1270	1730	1700	1700	2040	2448
SINUS PENTA 1296	-	-	-	1200	1650	2050	1400	1830	2000	1460	1990	2050	2100	2520	3024
Size S90³⁾															
SINUS PENTA 1800	-	-	-	1500	2000	2500	1750	2400	2500	1850	2500	2500	2600	3100	3720
SINUS PENTA 2076	-	-	-	1750	2400	2900	2000	2720	2900	2100	2900	2900	3000	3600	4000
Inverter power supply	200-240 Vac; 280-340 Vdc			380-500 Vac; 530-705 Vdc											

1) unavailable model as IP54 - 2) Cabinet version only available on demand - 3) input reactor and output reactor required.
 Key Inom= inverter nominal current • Imax= inverter maximum current for 120sec every 20min. up to S30 and 60sec. Every 10min. >=S41 • Ipeak= inverter maximum current for 3sec

SINUS PENTA 2T/4T



STANDARD OVERLOAD UP TO 140% (120s) OR UP TO 168% (3s)

Power supply up to 500 Vac

Sinus Penta Model	2T			4T									Inom	Imax	Ipeak (3s)
	200-240 Vac			380-415 Vac			440-460 Vac			480-500 Vac					
	kW	HP	A	kW	HP	A	kW	HP	A	kW	HP	A			
Size S05															
SINUS PENTA 0005	-	-	-	4	5.5	8.4	4.5	6	7.8	5.5	7.5	9	10.5	11.5	14
SINUS PENTA 0007	2.2	3	8.5	4.5	6	9	5.5	7.5	9.7	6.5	9	10.2	12.5	13.5	16
SINUS PENTA 0008	3	4	11.2	-	-	-	-	-	-	-	-	-	15	16	19
SINUS PENTA 0009	-	-	-	5.5	7.5	11.2	7.5	10	12.5	7.5	10	11.8	16.5	17.5	19
SINUS PENTA 0010	3.7	5	13.2	-	-	-	-	-	-	-	-	-	17	19	23
SINUS PENTA 0011	-	-	-	7.5	10	14.8	9.2	12.5	15.6	9.2	12.5	14.3	16.5	21	25
SINUS PENTA 0013	4	5.5	14.6	-	-	-	-	-	-	-	-	-	19	21	25
SINUS PENTA 0014	-	-	-	7.5	10	14.8	9.2	12.5	15.6	11	15	16.5	16.5	25	30
SINUS PENTA 0015	4.5	6	15.7	-	-	-	-	-	-	-	-	-	23	25	30
SINUS PENTA 0016	5.5	7.5	19.5	-	-	-	-	-	-	-	-	-	27	30	36
SINUS PENTA 0020 ¹⁾	7.5	10	25.7	-	-	-	-	-	-	-	-	-	30	36	43
Size S12															
SINUS PENTA 0016	-	-	-	9.2	12.5	17.9	11	15	18.3	15	20	23.2	27	30	36
SINUS PENTA 0017	-	-	-	11	15	21	11	15	18.3	15	20	23.2	30	32	37
SINUS PENTA 0020	-	-	-	15	20	29	15	20	25	18.5	25	28	30	36	43
SINUS PENTA 0023	9.2	12.5	30	-	-	-	-	-	-	-	-	-	38	42	51
SINUS PENTA 0025	-	-	-	18.5	25	35	18.5	25	30	22	30	33	41	48	58
SINUS PENTA 0030	-	-	-	22	30	41	22	30	36	25	35	37	41	56	67
SINUS PENTA 0033	11	15	36	-	-	-	-	-	-	-	-	-	51	56	68
SINUS PENTA 0034	-	-	-	25	35	46	30	40	48	30	40	44	57	63	76
SINUS PENTA 0036	-	-	-	30	40	55	30	40	48	37	50	53	60	72	86
SINUS PENTA 0037	15	20	50	-	-	-	-	-	-	-	-	-	65	72	83
Size S15															
SINUS PENTA 0040	18.5	25	61	30	40	55	37	50	58	40	55	58	72	80	88
SINUS PENTA 0049	22	30	71	37	50	67	45	60	70	45	60	64	80	96	115
Size S20															
SINUS PENTA 0060	25	35	80	45	60	80	55	75	85	55	75	78	88	112	134
SINUS PENTA 0067	30	40	96	55	75	98	60	80	91	65	90	88	103	118	142
SINUS PENTA 0074	37	50	117	65	90	114	70	95	107	75	100	103	120	144	173
SINUS PENTA 0086	40	55	127	75	100	133	75	100	116	85	115	120	135	155	186
Size S30															
SINUS PENTA 0113	45	60	135	90	125	159	90	125	135	90	125	127	180	200	240
SINUS PENTA 0129	55	75	170	100	135	180	110	150	166	110	150	153	195	215	258
SINUS PENTA 0150	65	90	195	110	150	191	132	180	198	150	200	211	215	270	324
SINUS PENTA 0162	75	100	231	132	180	228	150	200	230	160	220	218	240	290	324
Inverter power supply	200-240 Vac; 280-340 Vdc			380-500 Vac; 530-705 Vdc											

1) unavailable model as IP54 - 2) Cabinet version only available on demand - 3) input reactor and output reactor required.
 Key Inom= inverter nominal current • Imax= inverter maximum current for 120sec every 20min. up to S30 and 60sec. Every 10min. >=S41 • Ipeak= inverter maximum current for 3sec

SINUS PENTA 2T/4T



STANDARD OVERLOAD UP TO 140% (120s) OR UP TO 168% (3s)

Power supply up to 500 Vac

Sinus Penta Model	2T			4T									Inom	Imax	Ipeak (3s)
	200-240 Vac			380-415 Vac			440-460 Vac			480-500 Vac					
	kW	HP	A	kW	HP	A	kW	HP	A	kW	HP	A			
Size S41															
SINUS PENTA 0180	80	110	250	160	220	273	185	250	279	200	270	273	300	340	408
SINUS PENTA 0202	90	125	277	200	270	341	220	300	326	250	340	337	345	420	504
SINUS PENTA 0217	110	150	332	220	300	375	250	340	375	260	350	359	375	460	552
SINUS PENTA 0260	132	180	390	250	340	421	280	380	410	300	410	418	425	560	672
Size S51															
SINUS PENTA 0313	150	200	458	280	380	480	315	430	459	355	485	471	480	600	720
SINUS PENTA 0367	160	220	475	315	430	528	375	510	540	400	550	544	550	680	792
SINUS PENTA 0402	185	250	550	400	550	680	450	610	665	500	680	673	680	850	1020
Size S60															
SINUS PENTA 0457	220	300	661	400	550	680	450	610	665	500	680	673	720	880	1056
SINUS PENTA 0524	260	350	780	450	610	765	500	680	731	560	770	751	800	960	1152
Size S60P															
SINUS PENTA 0598P	-	-	-	500	680	841	560	760	817	630	860	864	900	1100	1152
Size S65³⁾															
SINUS PENTA 0598	-	-	-	500	680	841	560	760	817	630	860	864	900	1100	1320
SINUS PENTA 0748	-	-	-	560	760	939	630	860	939	710	970	960	1000	1300	1560
SINUS PENTA 0831	-	-	-	630	860	1080	800	1090	1160	800	1090	1067	1200	1440	1728
Size S75³⁾															
SINUS PENTA 0964	-	-	-	800	1090	1334	900	1230	1287	1000	1360	1317	1480	1780	2136
SINUS PENTA 1130	-	-	-	900	1230	1480	1100	1500	1630	1170	1600	1570	1700	2040	2448
SINUS PENTA 1296	-	-	-	1200	1650	2050	1400	1830	2000	1460	1990	2050	2100	2520	3024
Size S90³⁾															
SINUS PENTA 1800	-	-	-	1400	1910	2400	1700	2300	2400	1750	2400	2400	2600	3100	3720
SINUS PENTA 2076	-	-	-	1750	2400	2900	2000	2720	2900	2100	2900	2900	3000	3600	4000
Inverter power supply	200-240 Vac; 280-340 Vdc			380-500 Vac; 530-705 Vdc											

1) unavailable model as IP54 - 2) Cabinet version only available on demand - 3) input reactor and output reactor required.
 Key Inom= inverter nominal current • Imax= inverter maximum current for 120sec every 20min. up to S30 and 60sec. Every 10min. >=S41 • Ipeak= inverter maximum current for 3sec

SINUS PENTA 2T/4T



HEAVY OVERLOAD UP TO 175% (120s) OR UP TO 210% (3s)

Power supply up to 500 Vac

Sinus Penta Model	2T			4T									Inom	Imax	Ipeak (3s)
	200-240 Vac			380-415 Vac			440-460 Vac			480-500 Vac					
	kW	HP	A	kW	HP	A	kW	HP	A	kW	HP	A			
Size S05															
SINUS PENTA 0005	-	-	-	3	4	6.4	3.7	5	6.6	4.5	6	7.2	10.5	11.5	14
SINUS PENTA 0007	1.8	2.5	7.3	4	5.5	8.4	4.5	6	7.8	5.5	7.5	9	12.5	13.5	16
SINUS PENTA 0008	2.2	3	8.5	-	-	-	-	-	-	-	-	-	15	16	19
SINUS PENTA 0009	-	-	-	4.5	6	9	5.5	7.5	9.7	7.5	10	11.8	16.5	17.5	19
SINUS PENTA 0010	3	4	11.2	-	-	-	-	-	-	-	-	-	17	19	23
SINUS PENTA 0011	-	-	-	5.5	7.5	11.2	7.5	10	12.5	9.2	12.5	14.3	16.5	21	25
SINUS PENTA 0013	3.7	5	13.2	-	-	-	-	-	-	-	-	-	19	21	25
SINUS PENTA 0014	-	-	-	7.5	10	14.8	9.2	12.5	15.6	11	15	16.5	16.5	25	30
SINUS PENTA 0015	4	5.5	14.6	-	-	-	-	-	-	-	-	-	23	25	30
SINUS PENTA 0016	4.5	6	15.7	-	-	-	-	-	-	-	-	-	27	30	36
SINUS PENTA 0020 ¹⁾	5.5	7.5	19.5	-	-	-	-	-	-	-	-	-	30	36	43
Size S12															
SINUS PENTA 0016	-	-	-	9.2	12.5	17.9	11	15	18.3	12.5	17	18.9	27	30	36
SINUS PENTA 0017	-	-	-	9.2	12.5	17.9	11	15	18.3	12.5	17	18.9	30	32	37
SINUS PENTA 0020	-	-	-	11	15	21	15	20	25	15	20	23.2	30	36	43
SINUS PENTA 0023	7.5	10	25.7	-	-	-	-	-	-	-	-	-	38	42	51
SINUS PENTA 0025	-	-	-	15	20	29	18.5	25	30	18.5	25	28	41	48	58
SINUS PENTA 0030	-	-	-	18.5	25	35	22	30	36	22	30	33	41	56	67
SINUS PENTA 0033	11	15	36	-	-	-	-	-	-	-	-	-	51	56	68
SINUS PENTA 0034	-	-	-	22	30	41	25	35	40	28	38	41	57	63	76
SINUS PENTA 0036	-	-	-	25	35	46	30	40	48	30	40	44	60	72	86
SINUS PENTA 0037	15	20	50	-	-	-	-	-	-	-	-	-	65	72	83
Size S15															
SINUS PENTA 0040	15	20	50	25	35	46	30	40	48	37	50	53	72	80	88
SINUS PENTA 0049	18.5	25	61	30	40	55	37	50	58	45	60	64	80	96	115
Size S20															
SINUS PENTA 0060	22	30	71	37	50	67	45	60	70	50	70	70	88	112	134
SINUS PENTA 0067	25	35	80	45	60	80	50	70	75	55	75	78	103	118	142
SINUS PENTA 0074	30	40	96	50	70	87	55	75	85	65	90	88	120	144	173
SINUS PENTA 0086	32	45	103	55	75	98	65	90	100	75	100	103	135	155	186
Size S30															
SINUS PENTA 0113	45	60	135	75	100	133	75	100	116	90	125	127	180	200	240
SINUS PENTA 0129	50	70	150	80	110	144	90	125	135	110	150	153	195	215	258
SINUS PENTA 0150	55	75	170	90	125	159	110	150	166	132	180	180	215	270	324
SINUS PENTA 0162	65	90	195	110	150	191	132	180	198	140	190	191	240	290	324
Inverter power supply	200-240 Vac; 280-340 Vdc			380-500 Vac; 530-705 Vdc											

1) unavailable model as IP54 - 2) Cabinet version only available on demand - 3) input reactor and output reactor required.
Key Inom= inverter nominal current • Imax= inverter maximum current for 120sec every 20min. up to S30 and 60sec. Every 10min. >=S41 • Ipeak= inverter maximum current for 3sec

SINUS PENTA 2T/4T



HEAVY OVERLOAD UP TO 175% (120s) OR UP TO 210% (3s)

Power supply up to 500 Vac

Sinus Penta Model	2T			4T									Inom	Imax	Ipeak (3s)
	200-240 Vac			380-415 Vac			440-460 Vac			480-500 Vac					
	kW	HP	A	kW	HP	A	kW	HP	A	kW	HP	A			
Size S41															
SINUS PENTA 0180	75	100	231	132	180	228	160	220	237	160	220	218	300	340	408
SINUS PENTA 0202	80	110	250	150	200	264	185	250	279	200	270	273	345	420	504
SINUS PENTA 0217	110	150	332	185	250	321	220	300	326	220	300	300	375	460	552
SINUS PENTA 0260	110	150	332	200	270	341	260	350	390	280	380	393	425	560	672
Size S51															
SINUS PENTA 0313	132	180	390	220	300	375	260	350	390	300	400	413	480	600	720
SINUS PENTA 0367	150	200	458	250	340	421	315	430	459	355	485	471	550	680	792
SINUS PENTA 0402	160	220	475	315	430	528	375	510	540	400	550	544	680	850	1020
Size S60															
SINUS PENTA 0457	200	270	593	315	430	528	400	550	576	450	610	612	720	880	1056
SINUS PENTA 0524	220	300	661	355	480	589	450	610	665	500	680	673	800	960	1152
Size S60P															
SINUS PENTA 0598P	-	-	-	400	550	680	500	680	731	560	760	751	900	1100	1152
Size S65³⁾															
SINUS PENTA 0598	-	-	-	400	550	680	500	680	731	560	760	751	900	1100	1320
SINUS PENTA 0748	-	-	-	500	680	841	560	760	817	630	860	864	1000	1300	1560
SINUS PENTA 0831	-	-	-	560	760	939	630	860	939	710	970	960	1200	1440	1728
Size S75³⁾															
SINUS PENTA 0964	-	-	-	710	970	1200	800	1090	1160	900	1230	1184	1480	1780	2136
SINUS PENTA 1130	-	-	-	800	1090	1334	900	1230	1287	1000	1360	1317	1700	2040	2448
SINUS PENTA 1296	-	-	-	1000	1360	1650	1100	1500	1630	1170	1600	1560	2100	2520	3024
Size S90³⁾															
SINUS PENTA 1800	-	-	-	1200	1650	2050	1450	1970	2050	1500	2000	2050	2600	3100	3720
SINUS PENTA 2076	-	-	-	1400	1910	2400	1700	2300	2400	1750	2400	2400	3000	3600	4000
Inverter power supply	200-240 Vac; 280-340 Vdc			380-500 Vac; 530-705 Vdc											

1) unavailable model as IP54 - 2) Cabinet version only available on demand - 3) input reactor and output reactor required.
Key Inom= inverter nominal current • Imax= inverter maximum current for 120sec every 20min. up to S30 and 60sec. Every 10min. >=S41 • Ipeak= inverter maximum current for 3sec

SINUS PENTA 2T/4T



STRONG OVERLOAD UP TO 200% (120s) OR UP TO 240% (3s)

Power supply up to 500 Vac

Sinus Penta Model	2T			4T									Inom	Imax	Ipeak (3s)
	200-240 Vac			380-415 Vac			440-460 Vac			480-500 Vac					
	kW	HP	A	kW	HP	A	kW	HP	A	kW	HP	A			
Size S05															
SINUS PENTA 0005	-	-	-	2.2	3	4.9	3	4	5.6	3.7	5	6.1	10.5	11.5	14
SINUS PENTA 0007	1.5	2	6.1	3	4	6.4	3.7	5	6.6	4.5	6	7.2	12.5	13.5	16
SINUS PENTA 0008	1.8	2.5	7.3	-	-	-	-	-	-	-	-	-	15	16	19
SINUS PENTA 0009	-	-	-	4	5.5	8.4	4.5	6	7.8	5.5	7.5	9	16.5	17.5	19
SINUS PENTA 0010	2.2	3	8.5	-	-	-	-	-	-	-	-	-	17	19	23
SINUS PENTA 0011	-	-	-	4.5	6	9	5.5	7.5	9.7	7.5	10	11.8	16.5	21	25
SINUS PENTA 0013	3	4	11.2	-	-	-	-	-	-	-	-	-	19	21	25
SINUS PENTA 0014	-	-	-	5.5	7.5	11.2	7.5	10	12.5	9.2	12.5	14.3	16.5	25	30
SINUS PENTA 0015	3.7	5	13.2	-	-	-	-	-	-	-	-	-	23	25	30
SINUS PENTA 0016	4	5.5	14.6	-	-	-	-	-	-	-	-	-	27	30	36
SINUS PENTA 0020 ¹⁾	4.5	6	15.7	-	-	-	-	-	-	-	-	-	30	36	43
Size S12															
SINUS PENTA 0016	-	-	-	7.5	10	14.8	9.2	12.5	15.6	11	15	16.5	27	30	36
SINUS PENTA 0017	-	-	--	7.5	10	14.8	9.2	12.5	15.6	12.5	17	18.9	30	32	37
SINUS PENTA 0020	-	-	-	9.2	12.5	17.9	11	15	18.3	12.5	17	18.9	30	36	43
SINUS PENTA 0023	5.5	7.5	19.5	-	-	-	-	-	-	-	-	-	38	42	51
SINUS PENTA 0025	-	-	-	11	15	21	15	20	25	15	20	23.2	41	48	58
SINUS PENTA 0030	-	-	-	15	20	29	18.5	25	30	18.5	25	28	41	56	67
SINUS PENTA 0033	7.5	10	25.7	-	-	-	-	-	-	-	-	-	51	56	68
SINUS PENTA 0034	-	-	-	18.5	25	35	22	30	36	22	30	33	57	63	76
SINUS PENTA 0036	-	-	-	22	30	41	25	35	40	28	38	41	60	72	86
SINUS PENTA 0037	11	15	36	-	-	-	-	-	-	-	-	-	65	72	83
Size S15															
SINUS PENTA 0040	12.5	17	41	22	30	41	25	35	40	30	40	44	72	80	88
SINUS PENTA 0049	15	20	50	25	35	46	30	40	48	37	50	53	80	96	115
Size S20															
SINUS PENTA 0060	18.5	25	61	30	40	55	37	50	58	45	60	64	88	112	134
SINUS PENTA 0067	20	27	66	32	45	59	40	55	63	50	70	70	103	118	142
SINUS PENTA 0074	22	30	71	37	50	67	45	60	70	55	75	78	120	144	173
SINUS PENTA 0086	25	35	80	45	60	80	55	75	85	65	90	88	135	155	186
Size S30															
SINUS PENTA 0113	30	40	96	55	75	98	65	88	100	75	100	103	180	200	240
SINUS PENTA 0129	37	50	117	65	90	114	75	100	116	85	115	120	195	215	258
SINUS PENTA 0150	45	60	135	75	100	133	90	125	135	90	125	127	215	270	324
SINUS PENTA 0162	55	75	170	90	125	159	110	150	166	110	150	153	240	290	324
Inverter power supply	200-240 Vac; 280-340 Vdc			380-500 Vac; 530-705 Vdc											

1) unavailable model as IP54 - 2) Cabinet version only available on demand - 3) input reactor and output reactor required.
 Key Inom= inverter nominal current • Imax= inverter maximum current for 120sec every 20min. up to S30 and 60sec. Every 10min. >=S41 • Ipeak= inverter maximum current for 3sec

SINUS PENTA 2T/4T



STRONG OVERLOAD UP TO 200% (120s) OR UP TO 240% (3s)

Power supply up to 500 Vac

Sinus Penta Model	2T			4T									Inom	Imax	Ipeak (3s)
	200-240 Vac			380-415 Vac			440-460 Vac			480-500 Vac					
	kW	HP	A	kW	HP	A	kW	HP	A	kW	HP	A			
Size S41															
SINUS PENTA 0180	60	85	185	110	150	191	120	165	184	132	180	180	300	340	408
SINUS PENTA 0202	65	90	195	132	180	228	150	200	230	160	220	218	345	420	504
SINUS PENTA 0217	75	100	231	150	200	260	160	220	245	185	250	257	375	460	552
SINUS PENTA 0260	90	125	277	160	220	273	200	270	307	200	270	273	425	560	672
Size S51															
SINUS PENTA 0313	110	150	332	185	250	321	220	300	326	250	340	337	480	600	720
SINUS PENTA 0367	120	165	375	200	270	341	250	340	366	260	350	359	550	680	792
SINUS PENTA 0402	132	180	390	280	380	480	315	430	462	355	480	471	680	850	1020
Size S60															
SINUS PENTA 0457	160	220	475	280	380	480	330	450	493	375	510	497	720	880	1056
SINUS PENTA 0524	185	250	550	315	430	528	375	510	540	400	550	544	800	960	1152
Size S60P															
SINUS PENTA 0598P	-	-	-	355	480	589	400	550	591	450	610	612	900	1100	1152
Size S65³⁾															
SINUS PENTA 0598	-	-	-	355	480	589	400	550	591	450	610	612	900	1100	1320
SINUS PENTA 0748	-	-	-	400	550	680	500	680	731	560	760	751	1000	1300	1560
SINUS PENTA 0831	-	-	-	450	610	765	560	760	817	630	860	864	1200	1440	1728
Size S75²⁾															
SINUS PENTA 0964	-	-	-	560	770	939	710	970	1043	800	1090	1067	1480	1780	2136
SINUS PENTA 1130	-	-	-	710	970	1200	800	1090	1160	900	1230	1184	1700	2040	2448
SINUS PENTA 1296	-	-	-	800	1090	1334	900	1230	1287	1000	1360	1317	2100	2520	3024
Size S90²⁾															
SINUS PENTA 1800	-	-	-	1000	1360	1650	1170	1600	1650	1200	1650	1650	2600	3100	3720
SINUS PENTA 2076	-	-	-	1200	1650	2050	1450	1970	2050	1500	2000	2050	3000	3600	4000
Inverter power supply	200-240 Vac; 280-340 Vdc			380-500 Vac; 530-705 Vdc											

1) unavailable model as IP54 - 2) Cabinet version only available on demand - 3) input reactor and output reactor required.
 Key Inom= inverter nominal current • Imax= inverter maximum current for 120sec every 20min. up to S30 and 60sec. Every 10min. >=S41 • Ipeak= inverter maximum current for 3sec

SINUS PENTA 2T/4T



SINUS PENTA IP54 models

- The Sinus series also features an IP54-range suitable for environmental conditions with a strong presence of dust and water (up to SINUS PENTA S30).

- The robust metal enclosure is suitable for outdoor installations, therefore no electric cabinet is required.

Dimensions and weight IP54 models

Size	W (mm)	H (mm)	D (mm)	Weight (kg)
S05 ¹⁾	214	577	227	15.7
S12	250	622	268	23.3
S15	288	715	366	40
S20	339	842	366	57
S30	359	1008	460	76

1) model Sinus Penta 0020 2T unavailable as IP54

IP54 Front door operation (optional)

A complete set is available for front-door operation, including a potentiometer, an emergency push-button and a key-operated selector switch.

LOCAL (LOC) Enables motor speed adjustment via the inverter keypad

REMOTE (REM) Controls the inverter based on how it is programmed via terminal board, serial ports or fieldbus.





3 YEARS WARRANTY

SUPPLY VOLTAGE
5T = 500-600 VAC
6T = 575-690 VAC

5-function drives 1.3kW to 1240kW for:

- Three-phase asynchronous motor control
- Three-phase synchronous motor control
- Regeneration into the grid

- Wide power supply voltage range, 200÷500 Vac
- DC power supply range 280÷705 Vdc
- Input frequency 50-60 Hz
- Available in cabinet up to 3000 kW
- Enclosure IP00, IP20, IP54
- Full compatibility with the "REMOTE DRIVE" software for remote control

Technical Highlights

One product, 5 integrated functions

- **IFD** (Inverter Frequency Drive): vector modulation function for general-purpose applications (V/F pattern).
- **VTC** (Vector Torque Control): sensorless vector function for high-torque demanding applications.
- **FOC** (Field Oriented Control): vector function with encoder for high torque precision and wide speed range.
- **SYN** (Synchronous): vector function for brushless synchronous motors with permanent magnets, high torque precision joined to high energy efficiency level.
- **RGN** (Regenerative): sinusoidal power factor $\cos\Phi=1$, AC/DC feeder function for direct supply of a series of drives.
- Extremely compact dimensions: one of the best current density [A/m³] in the market!
- Widest range of STANDARD I/O.
- Most encoder input directly to control board, no option board required for FOC control.
- Open loop speed precision: $\pm 0.5\%$ of max. speed. Closed loop (with an encoder) speed precision: $< 0.01\%$ of max. speed.
- Intelligent cooling system. Through-Hole mounting, segregation of forced air flow channels.
- Integrated braking chopper up to S32 at 100% nominal current.
- Programmable logic blocks.
- Regulation of output frequency from 0 to 1000Hz (depending on models).
- Lower motor noise with random modulation and carrier frequency up to 16kHz (depending on models).
- Integrated EMC filters on the full range in compliance with EN61800-3 2nd ed.
- INTEGRATED INPUT FILTERS, EMC EN61800-3, 2nd edition, FIRST ENVIRONMENT Category C1, EN55011 gr.1 cl. B, for residential and industrial environments
- STO (Safe Torque Off) Function in compliance with EN 61800-5-2 SIL 3, EN ISO 13849 PL d.

Technical features

SINUS PENTA inverters fit any application thanks to their advanced features, among which: vector modulation; power control with the latest IGBTs; high immunity to radio interference; high overload capability.

- Easy commissioning with preset parameters for the most common applications.
- Operating parameters saved to removable keypad or PC and possibility of parameter transfer to multiple inverters.
- Control panel with 12 keys and large back-lit LCD.
- Automatic calibration for motor parameters tuning.
- Programmable multiple acceleration and deceleration ramps. Programmable S ramps.
- Automatic DC braking.
- Motor PTC thermal probe control. Integrated motor thermal protection.
- In case of power failure, total control of the motor, down to 0 RPM.
- Master-slave function for the operation of several motors connected to the same drive shaft (VTC and FOC).
- 200% max torque.
- PID Function / Second PID Function / 2-zone PID.
- Skip frequency.
- Integrated digital potentiometer. Integrated multifunctional tester.
- Fire Mode function available.
- Trip Log.
- STANDARD I/Os:
 - Encoder feedback
 - 8 programmable inputs and MPL logic
 - 3 programmable analog inputs 0-10 Vdc, 0(4)-20 mA, PTC
 - 4 programmable digital output (2 relays with exchange contact, 1 open-collector, 1 Push-Pull)
 - Auxiliary input frequency 5,000-65,000 Hz, Auxiliary output frequency 5,000-65,000 Hz
 - 3 programmable analog outputs 0-10 Vdc, 0(4)-20 mA.
- Auxiliary output voltage 24 Vdc, 10 Vdc.
- Serial communications RS485 with MODBUS RTU protocol up to 38.400 Baud.

Special configurations

- 12-pulse bridge: starting from the S65 size, it is possible to supply the drive on 12-pulse bridge configuration.
- Optional boards for Fieldbus communication, Encoder or Resolver interface, Data loggers, RTC, I/O expansion.
- Custom execution in box or cabinets with input and/or DC and/or output inductors, circuit breakers, AFE sensors and switch.

SINUS PENTA 5T/6T



Technical data

Connected Motor power range/voltage range

3~1000kW 525÷575Vac 3phase
3~1240kW 660÷690Vac 3phase

Mains Vac supply voltage and frequency

5T 500÷600 Vac, 3phase, -15% +10% 50÷60Hz
6T 575÷690 Vac, 3phase, -15% +10% 50÷60Hz

DC supply voltage

5T 705÷845 Vdc
6T 815÷970 Vdc

Overvoltage category

III (refer to EN 61800-5-1)

Degree of protection/size

IP20 from Size S12 to Size S32,
IP00 from Size S42 to Size S90,
IP54 from Size S12 to Size S32

Ambient temperature

-10°C to 55°C with no derating (or 2%/°C over 40°C based on the inverter model and the application category)

Storage temperature

-25 ÷ +70°C

Humidity

5 ÷ 95% (non condensing)

Altitude

Standard max. altitude 2000 m a.s.l
(2000 m ÷ 4000 m, on request)
Above 1000 m, derate 1%/100 m.

Vibrations

Lower than 9.8 m/sec² (= 1.0G)

Installation environment

No direct sunlight, conductive dust, corrosive gases, water sprinkling or dripping, or salty environments.

Operating atmospheric pressure

86 ÷ 106 kPa

Cooling system

Forced air-cooling



Dimensions and weight IP20 - IP00 models

Size	W (mm)	H (mm)	D (mm)	Weight (kg)
S12	215	401	225	12.5
S14	270	530	250	23
S22	282.5	813.5	353	52
S32	366.5	881	399	84
S42	500	968	409	136
S52	578	968	409	160
S65	980	1400	560	440
S70	1230	1400	960	440



SINUS PENTA 5T/6T



LIGHT OVERLOAD UP TO 120% (60s) OR UP TO 144% (3s)
Power supply up to 690 Vac

Atomizer	Positive displacement pumps
Bore pumps	Screw compressor, unloaded
Bottle washer	Slurry pumps
Centrifugal damped fan	Undamped axial fan
Centrifugal pumps	Undamped centrifugal fan
Damped axial fan	
Dust collector	
Grinder	
High pressure fan	

Sinus Penta Model	5T			6T			Inom.	Imax	Ipeak (3s)
	525-575 Vac			660-690 Vac					
	kW	HP	A	kW	HP	A			
Size S12									
SINUS PENTA 0003	4	5.5	5.7	5.5	7.5	6.3	7	8.5	10
SINUS PENTA 0004	5.5	7.5	7.6	7.5	10	8.4	9	11	13
SINUS PENTA 0006	7.5	10	10	9.2	12.5	10.2	11	13.5	16
SINUS PENTA 0012	9.2	12.5	12.5	11	15	12.1	13	16	19
SINUS PENTA 0018	11	15	14	15	20	16.8	17	21	25
Size S14									
SINUS PENTA 0003	4	5.5	5.7	5.5	7.5	6.3	7	8.5	10
SINUS PENTA 0004	5.5	7.5	7.6	7.5	10	8.4	9	11	13
SINUS PENTA 0006	7.5	10	10	9.2	12.5	10.2	11	13.5	16
SINUS PENTA 0012	9.2	12.5	12.5	11	15	12.1	13	16	19
SINUS PENTA 0018	11	15	14	15	20	16.8	17	21	25
SINUS PENTA 0019	15	20	20	18.5	25	21	21	25	30
SINUS PENTA 0021	18.5	25	25	22	30	23	25	30	36
SINUS PENTA 0022	22	30	28	30	40	33	33	40	48
SINUS PENTA 0024	30	40	39	37	50	39	40	48	58
SINUS PENTA 0032 ¹⁾	37	50	47	45	60	46	52	63	76
Size S22									
SINUS PENTA 0042	45	60	55	55	75	56	60	72	86
SINUS PENTA 0051	55	75	70	75	100	78	80	96	115
SINUS PENTA 0062	65	90	83	75	100	78	85	110	132
SINUS PENTA 0069	75	100	95	90	125	94	105	135	162
Size S32									
SINUS PENTA 0076	90	125	115	110	150	113	125	165	198
SINUS PENTA 0088	110	150	138	132	180	133	150	200	240
SINUS PENTA 0131	132	180	168	160	220	158	190	250	300
SINUS PENTA 0164	160	220	198	220	300	220	230	300	360
Size S42									
SINUS PENTA 0181	220	300	275	250	340	250	305	380	420
SINUS PENTA 0201	250	340	300	315	430	310	330	420	420
SINUS PENTA 0218	300	410	358	355	485	350	360	465	560
SINUS PENTA 0259	330	450	395	400	550	390	400	560	560
Size S52									
SINUS PENTA 0290	355	485	420	450	610	440	450	600	720
SINUS PENTA 0314	400	550	480	500	680	480	500	665	798
SINUS PENTA 0368	450	610	532	560	770	544	560	720	850
SINUS PENTA 0401	560	770	630	630	860	626	640	850	850
Inverter power supply	500-600 Vac; 705-845 Vdc			575-690 Vac; 845-970 Vdc					

1) unavailable model as IP54 - 2) Cabinet version only available on demand - 3) input reactor and output reactor required.
Key Inom= inverter nominal current • Imax= inverter maximum current for 60sec every 10min. up to S30 and 60sec. Every 10min. >=S41 • Ipeak= inverter maximum current for 3sec

SINUS PENTA 5T/6T



LIGHT OVERLOAD UP TO 120% (60s) OR UP TO 144% (3s)
Power supply up to 690 Vac

Sinus Penta Model	5T			6T			Inom.	Imax	Ipeak (3s)
	525-575 Vac			660-690 Vac					
	kW	HP	A	kW	HP	A			
Size S65³⁾									
SINUS PENTA 0457	630	860	720	710	970	696	720	880	1056
SINUS PENTA 0524	710	970	800	800	1090	773	800	960	1152
SINUS PENTA 0598	800	1090	900	900	1230	858	900	1100	1320
SINUS PENTA 0748	900	1230	1000	1000	1360	954	1000	1300	1440
Size S70³⁾									
SINUS PENTA 0831	1000	1360	1145	1240	1690	1200	1200	1440	1440
Size S75²⁾									
SINUS PENTA 0964	1270	1730	1480	1530	2090	1480	1480	1780	2136
SINUS PENTA 1130	1460	1990	1700	1750	2380	1700	1700	2040	2448
Size S80²⁾									
SINUS PENTA 1296	1750	2380	2100	2100	2860	2100	2100	2520	2520
Size S90²⁾									
SINUS PENTA 1800	2000	2720	2400	2400	3300	2400	2600	3100	3600
SINUS PENTA 2076	2500	3400	3000	3000	4000	3000	3000	3600	3600
Inverter power supply	500-600 Vac; 705-845 Vdc			575-690 Vac; 845-970 Vdc					

1) unavailable model as IP54 - 2) Cabinet version only available on demand - 3) input reactor and output reactor required.
Key Inom= inverter nominal current • Imax= inverter maximum current for 60sec every 10min. up to S30 and 60sec. Every 10min. >=S41 • Ipeak= inverter maximum current for 3sec

SINUS PENTA 5T/6T



STANDARD OVERLOAD UP TO 140% (60s) OR UP TO 168% (3s)
Power supply up to 690 Vac

Agitator Bandsaw Calenders Centrifuge Chipper Circular saw Conveyor belt Conveyor roller Crusher cone	Crusher rotary Crusher vertical impact Debarker Drawplates Dryer Edger Extruders Forming machines Hydraulic power pack	Industrial washers Mechanical presses Mixer Palletiser Rotary table Sander Screw compressor, loaded Screw injection moulding machines Separator	Shears Shredder Slicer Slurry pumps Tumbler Twister/Spinner Unloaded piston compressor Winding/unwinding machines
---	--	---	--

Sinus Penta Model	5T			6T			Inom.	Imax	Ipeak (3s)
	525-575 Vac			660-690 Vac					
	kW	HP	A	kW	HP	A			
Size S12									
SINUS PENTA 0003	4	5.5	5.7	4	5.5	4.8	7	8.5	10
SINUS PENTA 0004	5.5	7.5	7.6	5.5	7.5	6.3	9	11	13
SINUS PENTA 0006	7.5	10	10	7.5	10	8.4	11	13.5	16
SINUS PENTA 0012	7.5	10	10	9.2	12.5	10.2	13	16	19
SINUS PENTA 0018	11	15	14	11	15	12.1	17	21	25
Size S14									
SINUS PENTA 0003	4	5.5	5.7	4	5.5	4.8	7	8.5	10
SINUS PENTA 0004	5.5	7.5	7.6	5.5	7.5	6.3	9	11	13
SINUS PENTA 0006	7.5	10	10	7.5	10	8.4	11	13.5	16
SINUS PENTA 0012	7.5	10	10	9.2	12.5	10.2	13	16	19
SINUS PENTA 0018	11	15	14	11	15	12.1	17	21	25
SINUS PENTA 0019	11	15	14	15	20	16.8	21	25	30
SINUS PENTA 0021	15	20	20	18.5	25	21	25	30	36
SINUS PENTA 0022	22	30	28	22	30	23	33	40	48
SINUS PENTA 0024	25	35	32	30	40	33	40	48	58
SINUS PENTA 0032 ¹⁾	37	50	47	37	50	39	52	63	76
Size S22									
SINUS PENTA 0042	45	60	55	45	60	46	60	72	86
SINUS PENTA 0051	55	75	70	55	75	56	80	96	115
SINUS PENTA 0062	65	90	83	75	100	77	85	110	132
SINUS PENTA 0069	75	100	95	90	125	95	105	135	162
Size S32									
SINUS PENTA 0076	90	125	115	110	150	113	125	165	198
SINUS PENTA 0088	110	150	135	132	180	133	150	200	240
SINUS PENTA 0131	132	180	168	160	220	158	190	250	300
SINUS PENTA 0164	160	220	198	200	270	198	230	300	360
Size S42									
SINUS PENTA 0181	220	300	275	250	340	250	305	380	420
SINUS PENTA 0201	250	340	300	315	430	310	330	420	420
SINUS PENTA 0218	300	410	358	315	430	310	360	465	560
SINUS PENTA 0259	330	450	395	400	550	390	400	560	560
Size S52									
SINUS PENTA 0290	355	485	420	450	610	440	450	600	720
SINUS PENTA 0314	400	550	480	450	610	440	500	665	798
SINUS PENTA 0368	450	610	532	500	680	480	560	720	850
SINUS PENTA 0401	450	610	532	630	860	626	640	850	850
Inverter power supply	500-600 Vac; 705-845 Vdc			575-690 Vac; 845-970 Vdc					

1) unavailable model as IP54 - 2) Cabinet version only available on demand - 3) input reactor and output reactor required.
Key Inom= inverter nominal current • Imax= inverter maximum current for 60sec every 10min. up to S30 and 60sec. Every 10min. >=S41 • Ipeak= inverter maximum current for 3sec

SINUS PENTA 5T/6T



STANDARD OVERLOAD UP TO 140% (60s) OR UP TO 168% (3s)
Power supply up to 690 Vac

Sinus Penta Model	5T			6T			Inom.	Imax	Ipeak (3s)
	525-575 Vac			660-690 Vac					
	kW	HP	A	kW	HP	A			
Size S65³⁾									
SINUS PENTA 0457	560	770	630	630	860	626	720	880	1056
SINUS PENTA 0524	630	860	720	710	970	696	800	960	1152
SINUS PENTA 0598	710	970	800	900	1230	858	900	1100	1320
SINUS PENTA 0748	900	1230	1000	1000	1360	954	1000	1300	1440
Size S70³⁾									
SINUS PENTA 0831	1000	1360	1145	1100	1500	1086	1200	1440	1440
Size S75²⁾									
SINUS PENTA 0964	1180	1610	1369	1410	1920	1369	1480	1780	2136
SINUS PENTA 1130	1350	1840	1569	1620	2210	1569	1700	2040	2448
Size S80²⁾									
SINUS PENTA 1296	1750	2380	2100	1850	2520	1800	2100	2520	2520
Size S90²⁾									
SINUS PENTA 1800	2000	2720	2400	2400	3300	2400	2600	3100	3600
SINUS PENTA 2076	2500	3400	3000	3000	4000	3000	3000	3600	3600
Inverter power supply	500-600 Vac; 705-845 Vdc			575-690 Vac; 845-970 Vdc					

1) unavailable model as IP54 - 2) Cabinet version only available on demand - 3) input reactor and output reactor required.
Key Inom= inverter nominal current • Imax= inverter maximum current for 60sec every 10min. up to S30 and 60sec. Every 10min. >=S41 • Ipeak= inverter maximum current for 3sec

SINUS PENTA 5T/6T



HEAVY OVERLOAD UP TO 175% (60s) OR UP TO 210% (3s)
Power supply up to 690 Vac

Ball mill
 Calenders
 Conveyor belt
 Conveyor screw
 Crusher jaw
 Dryer
 Elevators
 Hammer mill
 Hoists and cranes' translation

injection moulding machines
 Loaded piston compressor
 Mill
 Roller mill
 Screw injection moulding machines

Sinus Penta Model	5T			6T			Inom.	Imax	Ipeak (3s)
	525-575 Vac			660-690 Vac					
	kW	HP	A	kW	HP	A			
Size S12									
SINUS PENTA 0003	3	4	4.4	4	5.5	4.8	7	8.5	10
SINUS PENTA 0004	4	5.5	5.7	4	5.5	4.8	9	11	13
SINUS PENTA 0006	5.5	7.5	7.6	7.5	10	8.4	11	13.5	16
SINUS PENTA 0012	7.5	10	10	7.5	10	8.4	13	16	19
SINUS PENTA 0018	9.2	12.5	12.5	11	15	12.1	17	21	25
Size S14									
SINUS PENTA 0003	3	4	4.4	4	5.5	4.8	7	8.5	10
SINUS PENTA 0004	4	5.5	5.7	4	5.5	4.8	9	11	13
SINUS PENTA 0006	5.5	7.5	7.6	7.5	10	8.4	11	13.5	16
SINUS PENTA 0012	7.5	10	10	7.5	10	8.4	13	16	19
SINUS PENTA 0018	9.2	12.5	12.5	11	15	12.1	17	21	25
SINUS PENTA 0019	11	15	14	11	15	12.1	21	25	30
SINUS PENTA 0021	15	20	20	15	20	16.8	25	30	36
SINUS PENTA 0022	18.5	25	25	22	30	23	33	40	48
SINUS PENTA 0024	22	30	28	22	30	23	40	48	58
SINUS PENTA 0032 ¹⁾	30	40	39	37	50	39	52	63	76
Size S22									
SINUS PENTA 0042	37	50	47	37	50	39	60	72	86
SINUS PENTA 0051	45	60	55	55	75	56	80	96	115
SINUS PENTA 0062	55	75	70	55	75	56	85	110	132
SINUS PENTA 0069	55	75	70	75	100	78	105	135	162
Size S32									
SINUS PENTA 0076	75	100	95	90	125	94	125	165	198
SINUS PENTA 0088	110	150	135	110	150	113	150	200	240
SINUS PENTA 0131	110	150	135	160	220	158	190	250	300
SINUS PENTA 0164	132	180	168	185	250	185	230	300	360
Size S42									
SINUS PENTA 0181	185	250	225	220	300	220	305	380	420
SINUS PENTA 0201	200	270	240	250	340	250	330	420	420
SINUS PENTA 0218	220	300	275	315	430	310	360	465	560
SINUS PENTA 0259	280	380	336	355	485	341	400	560	560
Taglia S52									
SINUS PENTA 0290	300	400	358	400	550	390	450	600	720
SINUS PENTA 0314	330	450	395	450	610	440	500	665	798
SINUS PENTA 0368	355	485	420	500	680	480	560	720	850
SINUS PENTA 0401	400	550	473	560	770	544	640	850	850
Inverter power supply	500-600 Vac; 705-845 Vdc			575-690 Vac; 845-970 Vdc					

1) unavailable model as IP54 - 2) Cabinet version only available on demand - 3) input reactor and output reactor required.
 Key Inom= inverter nominal current • Imax= inverter maximum current for 60sec every 10min. up to S30 and 60sec. Every 10min. >=S41 • Ipeak= inverter maximum current for 3sec

SINUS PENTA 5T/6T



HEAVY OVERLOAD UP TO 175% (60s) OR UP TO 210% (3s)
Power supply up to 690 Vac

Sinus Penta Model	5T			6T			Inom.	Imax	Ipeak (3s)
	525-575 Vac			660-690 Vac					
	kW	HP	A	kW	HP	A			
Size S65³⁾									
SINUS PENTA 0457	500	680	585	560	770	544	720	880	1056
SINUS PENTA 0524	560	770	630	630	860	626	800	960	1152
SINUS PENTA 0598	630	860	720	710	970	696	900	1100	1320
SINUS PENTA 0748	710	970	800	900	1230	858	1000	1300	1440
Size S70³⁾									
SINUS PENTA 0831	800	1090	900	1000	1360	954	1200	1440	1440
Size S75³⁾									
SINUS PENTA 0964	1000	1360	1145	1220	1660	1187	1480	1780	2136
SINUS PENTA 1130	1170	1600	1360	1400	1910	1360	1700	2040	2448
Size S80³⁾									
SINUS PENTA 1296	1340	1830	1560	1610	2190	1560	2100	2520	2520
Size S90³⁾									
SINUS PENTA 1800	1750	2400	2050	2100	2860	2100	2600	3100	3600
SINUS PENTA 2076	2000	2720	2400	2400	3300	2400	3000	3600	3600
Inverter power supply	500-600 Vac; 705-845 Vdc			575-690 Vac; 845-970 Vdc					

1) unavailable model as IP54 - 2) Cabinet version only available on demand - 3) input reactor and output reactor required.
 Key Inom= inverter nominal current • Imax= inverter maximum current for 60sec every 10min. up to S30 and 60sec. Every 10min. >=S41 • Ipeak= inverter maximum current for 3sec

SINUS PENTA 5T/6T



STRONG OVERLOAD UP TO 200% (60s) OR UP TO 240% (3s)
Power supply up to 690 Vac

Axis control
 Chucks
 Injection presses
 Hydraulic power pack
 Lifting

Sinus Penta Model	5T			6T			Inom.	Imax	Ipeak (3s)
	525-575 Vac			660-690 Vac					
	kW	HP	A	kW	HP	A			
Size S12									
SINUS PENTA 0003	3	4	4.4	3	4	3.7	7	8.5	10
SINUS PENTA 0004	4	5.5	5.7	4	5.5	4.8	9	11	13
SINUS PENTA 0006	4	5.5	5.7	5.5	7.5	6.3	11	13.5	16
SINUS PENTA 0012	5.5	7.5	7.6	7.5	10	8.4	13	16	19
SINUS PENTA 0018	7.5	10	10	9.2	12.5	10.2	17	21	25
Size S14									
SINUS PENTA 0003	3	4	4.4	3	4	3.7	7	8.5	10
SINUS PENTA 0004	4	5.5	5.7	4	5.5	4.8	9	11	13
SINUS PENTA 0006	4	5.5	5.7	5.5	7.5	6.3	11	13.5	16
SINUS PENTA 0012	5.5	7.5	7.6	7.5	10	8.4	13	16	19
SINUS PENTA 0018	7.5	10	10	9.2	12.5	10.2	17	21	25
SINUS PENTA 0019	9.2	12.5	12.5	11	15	12	21	25	30
SINUS PENTA 0021	11	15	14	11	15	12	25	30	36
SINUS PENTA 0022	15	20	20	18.5	25	21	33	40	48
SINUS PENTA 0024	18.5	25	25	22	30	23	40	48	58
SINUS PENTA 0032 ¹⁾	25	35	32	30	40	33	52	63	76
Size S22									
SINUS PENTA 0042	30	40	39	30	40	33	60	72	86
SINUS PENTA 0051	37	50	47	45	60	46	80	96	115
SINUS PENTA 0062	45	60	55	55	75	56	85	110	132
SINUS PENTA 0069	45	60	55	55	75	56	105	135	162
Size S32									
SINUS PENTA 0076	55	75	70	75	100	77	125	165	198
SINUS PENTA 0088	75	100	95	90	125	95	150	200	240
SINUS PENTA 0131	90	125	115	110	150	115	190	250	300
SINUS PENTA 0164	110	150	138	132	180	140	230	300	360
Size S42									
SINUS PENTA 0181	160	220	198	200	270	198	305	380	420
SINUS PENTA 0201	160	220	198	220	300	220	330	420	420
SINUS PENTA 0218	200	270	240	250	340	250	360	465	560
SINUS PENTA 0259	220	300	275	315	430	310	400	560	560
Size S52									
SINUS PENTA 0290	250	340	300	355	480	341	450	600	720
SINUS PENTA 0314	280	380	336	375	510	360	500	665	798
SINUS PENTA 0368	315	430	367	400	550	390	560	720	850
SINUS PENTA 0401	355	480	410	500	680	480	640	850	850
Inverter power supply	500-600 Vac; 705-845 Vdc			575-690 Vac; 845-970 Vdc					

1) unavailable model as IP54 - 2) Cabinet version only available on demand - 3) input reactor and output reactor required.
 Key Inom= inverter nominal current • Imax= inverter maximum current for 60sec every 10min. up to S30 and 60sec. Every 10min. >=S41 • Ipeak= inverter maximum current for 3sec

SINUS PENTA 5T/6T



STRONG OVERLOAD UP TO 200% (60s) OR UP TO 240% (3s)
Power supply up to 690 Vac

Sinus Penta Model	5T			6T			Inom.	Imax	Ipeak (3s)
	525-575 Vac			660-690 Vac					
	kW	HP	A	kW	HP	A			
Size S65³⁾									
SINUS PENTA 0457	400	550	480	500	680	480	720	880	1056
SINUS PENTA 0524	450	610	532	560	770	544	800	960	1152
SINUS PENTA 0598	560	770	630	630	860	626	900	1100	1320
SINUS PENTA 0748	630	860	720	800	1090	773	1000	1300	1440
Size S70³⁾									
SINUS PENTA 0831	710	970	800	900	1230	858	1200	1440	1440
Size S75³⁾									
SINUS PENTA 0964	900	1230	1000	1000	1360	954	1480	1780	2136
SINUS PENTA 1130	1000	1360	1145	1100	1500	1086	1700	2040	2448
Size S80³⁾									
SINUS PENTA 1296	1150	1570	1337	1380	1880	1337	2100	2520	2520
Size S90³⁾									
SINUS PENTA 1800	1460	1990	1700	1750	2380	1700	2600	3100	3600
SINUS PENTA 2076	1750	2400	2050	2100	2860	2100	3000	3600	3600
Inverter power supply	500-600 Vac; 705-845 Vdc			575-690 Vac; 845-970 Vdc					

1) unavailable model as IP54 - 2) Cabinet version only available on demand - 3) input reactor and output reactor required.
 Key Inom= inverter nominal current • Imax= inverter maximum current for 60sec every 10min. up to S30 and 60sec. Every 10min. >=S41 • Ipeak= inverter maximum current for 3sec

SINUS PENTA 5T/6T



S12



S14



S22



S32

SINUS PENTA IP54 models

- The Sinus series also features an IP54-range suitable for environmental conditions with a strong presence of dust and water (up to SINUS PENTA S32).

- The robust metal enclosure is suitable for outdoor installations, therefore no electric cabinet is required

Dimensions and weight IP54 models

Size	W (mm)	H (mm)	D (mm)	Weight (kg)
S12	250	622	268	23
S14 ¹⁾	310	751	295	31
S22	345	1075	465	86
S32	431	1160	471	113

1) model Sinus Penta 0032 5T/6T unavailable as IP54

IP54 Front door operation (optional)

A complete set is available for front-door operation, including a potentiometer, an emergency push-button and a key-operated selector switch.

LOCAL (LOC) Enables motor speed adjustment via the inverter keypad

REMOTE (REM) Controls the inverter based on how it is programmed via terminal board, serial ports or fieldbus.



SINUS PENTA IN CABINET

SINUS PENTA IN CABINET (on demand)



Technical features & highlights

Sinus PENTA line inverters can be provided in cabinet. A custom made solution is given by a choice of options.

- IP24 ÷ IP54 enclosure
- Input three-pole switch with fast fuses
- Input three-pole circuit breaker
- AC1 input three-pole contactor
- Board front operation with key selector
- LOCAL/REMOTE command and EMERGENCY push-button
- Input chokes
- Motor side output chokes
- EMC filters
- Supplementary terminal board for input and output cables
- Output ferrite filter
- Power supply circuit for servoveilation
- Braking module for sizes \geq S41
- Internal resistor against condensation
- PT100 motor thermal probe instrument
- Front back-lit display keypad
- Special customer requests



3 YEARS WARRANTY

SUPPLY VOLTAGE
 2T = 200-240 VAC
 4T = 380-500 VAC
 5T = 500-600 VAC
 6T = 575-690 VAC

3kW to 3000kW SINUS PENTA CABINET on demand for:

- Three-phase asynchronous motor control
- Three-phase synchronous motor control
- Regeneration into the grid

- Wide power supply voltage range, 200÷690 Vac
- DC power supply range 280÷970 Vdc
- Input frequency 50 - 60 Hz
- Enclosure IP24, IP34, IP54
- Many different options available, please contact Santerno Pre-Sales office
- Full compatibility with the "REMOTE DRIVE" software for remote control

Dimensions and weight CABINET models*

Size	Sinus Penta Cabinet model	Voltage class	W (mm)	H (mm)	D (mm)	Weight (kg)
S15C	0040-0049	2T-4T	600	2270	500	130
S20C	0060-0067-0074-0086	2T-4T	600	2270	500	140-143
S22C	0042-0051-0062-0069	5T-6T	600	2270	500	158-161
S30C	0113-0129-0150-0162	2T-4T	600	2270	600	162
S32C	0076-0088-0131-0164	5T-6T	600	2270	600	191-195
S41C	0180-0202-0217-0260	2T-4T	1000	2270	600	280
S42C	0181-0218-0259	5T-6T	1000	2270	600	300
S51C	0313-0367-0402	2T-4T	1200	2270	600	350
S52C	0290-0314-0368-0401	5T-6T	1200	2270	600	370
S60C	0457-0524	2T-4T	1600	2675	800	586
S65C	0598-0748-0831-0457-0524-0598-0748	4T-5T-6T	2000	2675	800	854
S70C	0831	5T-6T	2200	2675	800	1007

*Dimensions and weights may change according to the required optionals.



Internal features

PENTA CABINET 6-pulse power supply, no braking unit

S75 - 6-pulse



S80 - 6-pulse



S90 - 6-pulse



PENTA CABINET 12-pulse power supply, no braking unit

S75 - 12-pulse



S80 - 12-pulse



S90 - 12-pulse



PENTA CABINET regenerative Active Front End (AFE)

S74+S74 RGN



S84+S84 RGN

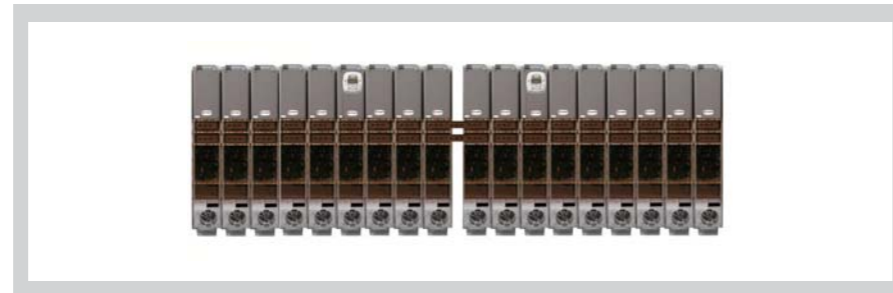

Technical features & highlights

Standard solution for SINUS PENTA drives in cabinet, coming in 4 different configurations:

- With a 6-pulse power supply rectifier, without braking unit
- With a 6-pulse power supply rectifier, with braking unit
- With a 12-pulse power supply rectifier, without braking unit
- With a 12-pulse power supply rectifier, with braking unit
- Back to Back solution with a regenerative SINUS PENTA RGN as Active Front End, without braking unit

All the solutions include:

- Circuit Breaker + release contact + auxiliary contact
- Input inductors
- Output inductors
- INTEGRATED INPUT FILTERS, EMC EN61800-3, 2nd edition, FIRST ENVIRONMENT Category C1, EN55011 gr.1 cl. B, for residential and industrial environments
- Fans for air cooling
- Front door operation + 5 push buttons-selectors and terminals
- Front door display-keypad

Features

- SINUS PENTA Drive with V/F, Sensorless VTC, FOC control algorithm for AC three phase induction motors
- Motor power up to 3000kW depending on voltage and application (see tables)
- 3 different supply input voltages available: 4T=380-500 Vac, 5T=500-600 Vac, 6T=575-690 Vac
- Input frequency 50 - 60 Hz
- IP24, IP34, IP41, IP42 degree of protection (on request)

Options

- All Communications, Datalogger and RTC, Speed Sensors, I/O expansion boards for SINUS PENTA
- Compatible with Easy Harmonics, tool for the calculation of Harmonic currents mitigation

SINUS PENTA IN CABINET (on demand)



Configurations, dimensions and weight

Model	Size	Voltage class (Vac)	Circuit breakers	Power supply unit	IGBT module units	Braking units	Dimensions (mm) (WxHxD)	Weight (kg)
6-PULSE Power Supply, no braking unit								
PENTA CABINET 0964 4T XA2K300	S75	380-500	1	2	6	N.A	3600X2675X800	2580
PENTA CABINET 0964 5T/6T XA2K300		500-600 / 575-690					3600X2675X800	2600
PENTA CABINET 1130 4T XA2K300	S75	380-500	1	2	6	N.A	3600X2675X800	2600
PENTA CABINET 1130 5T/6T XA2K300		500-600 / 575-690					3600X2675X800	2650
PENTA CABINET 1296 4T XA2K300	S80	380-500	1	3	6	N.A	4000X2675X800	2880
PENTA CABINET 1296 5T/6T XA2K300		500-600 / 575-690					4000X2675X800	2930
PENTA CABINET 1800 4T XA2K300	S90	380-500	1	3	9	N.A	5000X2675X800	3880
PENTA CABINET 1800 5T/6T XA2K300		500-600 / 575-690					6000X2675X800	4320
PENTA CABINET 2076 4T XA2K300	S90	380-500	1	3	9	N.A	5000X2675X800	3900
PENTA CABINET 2076 5T/6T XA2K300		500-600 / 575-690					6000X2675X800	4340
12-PULSE Power Supply, no braking unit								
PENTA CABINET 0964 4D XA2K300	S75	380-500	2	2	6	N.A	3800X2675X800	2590
PENTA CABINET 0964 5D/6D XA2K300		500-600 / 575-690					3800X2675X800	2630
PENTA CABINET 1130 4D XA2K300	S75	380-500	2	2	6	N.A	3800X2675X800	2590
PENTA CABINET 1130 5D/6D XA2K300		500-600 / 575-690					3800X2675X800	2680
PENTA CABINET 1296 4D XA2K300	S80	380-500	2	4	6	N.A	4600X2675X800	3220
PENTA CABINET 1296 5D/6D XA2K300		500-600 / 575-690					5200X2675X800	3550
PENTA CABINET 1800 4D XA2K300	S90	380-500	2	4	9	N.A	6000X2675X800	4230
PENTA CABINET 1800 5D/6D XA2K300		500-600 / 575-690					6600X2675X800	4650
PENTA CABINET 2076 4D XA2K300	S90	380-500	2	4	9	N.A	6000X2675X800	4250
PENTA CABINET 2076 5D/6D XA2K300		500-600 / 575-690					6600X2675X800	4670
6-PULSE Power Supply with braking unit								
PENTA CABINET 0964 4T BA2K300	S75	380-500	2	2	6	1	4000X2675X800	2740
PENTA CABINET 0964 5T/6T BA2K300		500-600 / 575-690					4000X2675X800	2930
PENTA CABINET 1130 4T BA2K300	S75	380-500	1	2	6	1	4000X2675X800	2740
PENTA CABINET 1130 5T/6T BA2K300		500-600 / 575-690					4200X2675X800	2980
PENTA CABINET 1296 4T BA2K300	S80	380-500	1	3	9	2	4600X2675X800	3150
PENTA CABINET 1296 5T/6T BA2K300		500-600 / 575-690					4600X2675X800	3260
PENTA CABINET 1800 4T BA2K300	S90	380-500	1	3	9	2	5600X2675X800	4210
PENTA CABINET 1800 5T/6T BA2K300		500-600 / 575-690					5600X2675X800	4210
PENTA CABINET 2076 4T BA2K300	S90	380-500	1	3	9	2	5600X2675X800	4230
PENTA CABINET 2076 5T/6T BA2K300		500-600 / 575-690					5600X2675X800	4230
12-PULSE Power Supply with braking unit								
PENTA CABINET 0964 4D BA2K300	S75	380-500	2	2	6	1	4200X2675X800	2770
PENTA CABINET 0964 5D/6D BA2K300		500-600 / 575-690					4400X2675X800	2650
PENTA CABINET 1130 4D BA2K300	S75	380-500	2	2	6	1	4200X2675X800	2770
PENTA CABINET 1130 5D/6D BA2K300		500-600 / 575-690					4400X2675X800	3000
PENTA CABINET 1296 4D BA2K300	S80	380-500	2	4	6	2	5200X2675X800	3400
PENTA CABINET 1296 5D/6D BA2K300		500-600 / 575-690					5200X2675X800	3550
PENTA CABINET 1800 4D BA2K300	S90	380-500	2	4	9	2	6600X2675X800	4570
PENTA CABINET 1800 5D/6D BA2K300		500-600 / 575-690					6600X2675X800	4650
PENTA CABINET 2076 4D BA2K300	S90	380-500	2	4	9	2	6600X2675X800	4590
PENTA CABINET 2076 5D/6D BA2K300		500-600 / 575-690					6600X2675X800	4670

SINUS PENTA IN CABINET (on demand)



Configurations, dimensions and weight

Model	Size	Voltage class (Vac)	Circuit breakers	Power supply unit	IGBT module units	Braking units	Dimensions (mm) (WxHxD)	Weight (kg)
Regenerative Active Front End								
PENTA CABINET RGN 0964 4C XA2K300	S74+S74	380-500	1	N.A	6+6	N.A	7400X2675X1000	5140
PENTA CABINET RGN 0964 5C/6C XA2K300		500-600 / 575-690					7400X2675X1000	5770
PENTA CABINET RGN 1130 4C XA2K300	S74+S74	380-500	1	N.A	6+6	N.A	7400X2675X1000	5140
PENTA CABINET RGN 1130 5C/6C XA2K300		500-600 / 575-690					7400X2675X1000	5770
PENTA CABINET RGN 1296 4C XA2K300	S74+S74	380-500	1	N.A	6+6	N.A	7400X2675X1000	5800
PENTA CABINET RGN 1296 5C/6C XA2K300		500-600 / 575-690					7400X2675X1000	5800
PENTA CABINET RGN 1800 4C XA2K300	S84+S84	380-500	1	N.A	9+9	N.A	10800X2675X1000	8360
PENTA CABINET RGN 1800 5C/6C XA2K300		500-600 / 575-690					10800X2675X1000	8720
PENTA CABINET RGN 2076 4C XA2K300	S84+S84	380-500	1	N.A	9+9	N.A	10800X2675X1000	8400
PENTA CABINET RGN 2076 5C/6C XA2K300		500-600 / 575-690					10800X2675X1000	8760



SINUS PENTA BOX IP54

WALL MOUNTING



3 YEARS WARRANTY

SUPPLY VOLTAGE
2T = 200-240 VAC
4T = 380-500 VAC
5T = 500-600 VAC
6T = 575-690 VAC

5-function 1.3kW to 90kW drives in IP54 box for:

- Three-phase asynchronous motor control
- Three-phase synchronous motor control

- Wide power supply voltage range, 200Vac - 690Vac.
- Input frequency 50 - 60Hz
- Power range 1.3 - 90kW
- Full compatibility with the "REMOTE DRIVE" software for remote control

SINUS PENTA IN BOX IP54



Technical features & highlights

Sinus PENTA line inverters can be provided in box up to IP54 protection degree. A custom made solution is given by a choice of options.

- Input three pole switch circuit breaker
- AC1 input three pole contactor
- Front operation board by key selector LOCAL/REMOTE command and EMERGENCY push-button
- Input chokes
- Motor side output chokes
- Power supply circuit for servoveilation
- Internal resistor against condensation
- Supplementary terminal board for input and output cables
- Front back-lit display with keyboard

Dimensions and weight BOX models

Size	W (mm)	H (mm)	D (mm)	Weight (kg)
S05B	400	600	290	27.9
S12B	500	700	300	50.5
S15B	600	1000	400	78.2
S20B	600	1200	400	112.3

*Dimensions and weights may change according to the required optionals.

Harmonic currents

Harmonic current is generated by non linear loads absorbing non-sinusoidal current. Typical sources of this type are bridge rectifiers (power electronics), switching power supply units and fluorescent lamps. Three-phase rectifiers absorb line current with a harmonic content $n=6K\pm 1$ with $K=1,2,3,\dots$ (e.g. 5th, 7th, 11th, 13th, 17th, 19th, etc.). Harmonic current amplitude decreases when frequency increases. Harmonic current carries no active power; it is additional current carried by electrical cables. Typical effects are: conductor overload, power factor decrease and measurement systems instability. Voltage generated by current flowing in the transformer reactance may also damage other appliances or interfere with mains-synchronized switching equipment.

Santerno inverters

Santerno inverters are specifically designed to reduce line harmonics thanks to mutual design and dimensioning of the DC capacitors, rectifier diodes and the input EMI filter inductors. Input AC line reactors and DC reactors can be selected to further reduce harmonics.

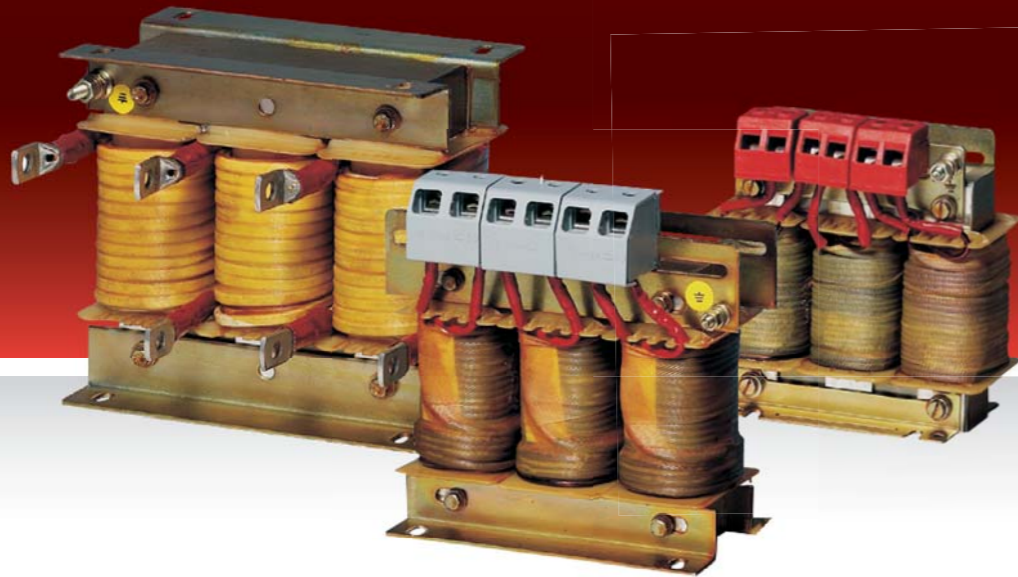

Input, DC, Output Inductors. Current harmonic and dv/dt mitigation

- Limit input current peaks on the input circuit of the inverter
- limit di/dt due to the input rectifier and to the capacitive load of the capacitors set;
- Reduce supply harmonic current;
- Increase power factor, thus reducing line current;
- Increase the duration of line capacitors inside the inverter.
- The output inductors reduce the dv/dt on motor cable and windings.

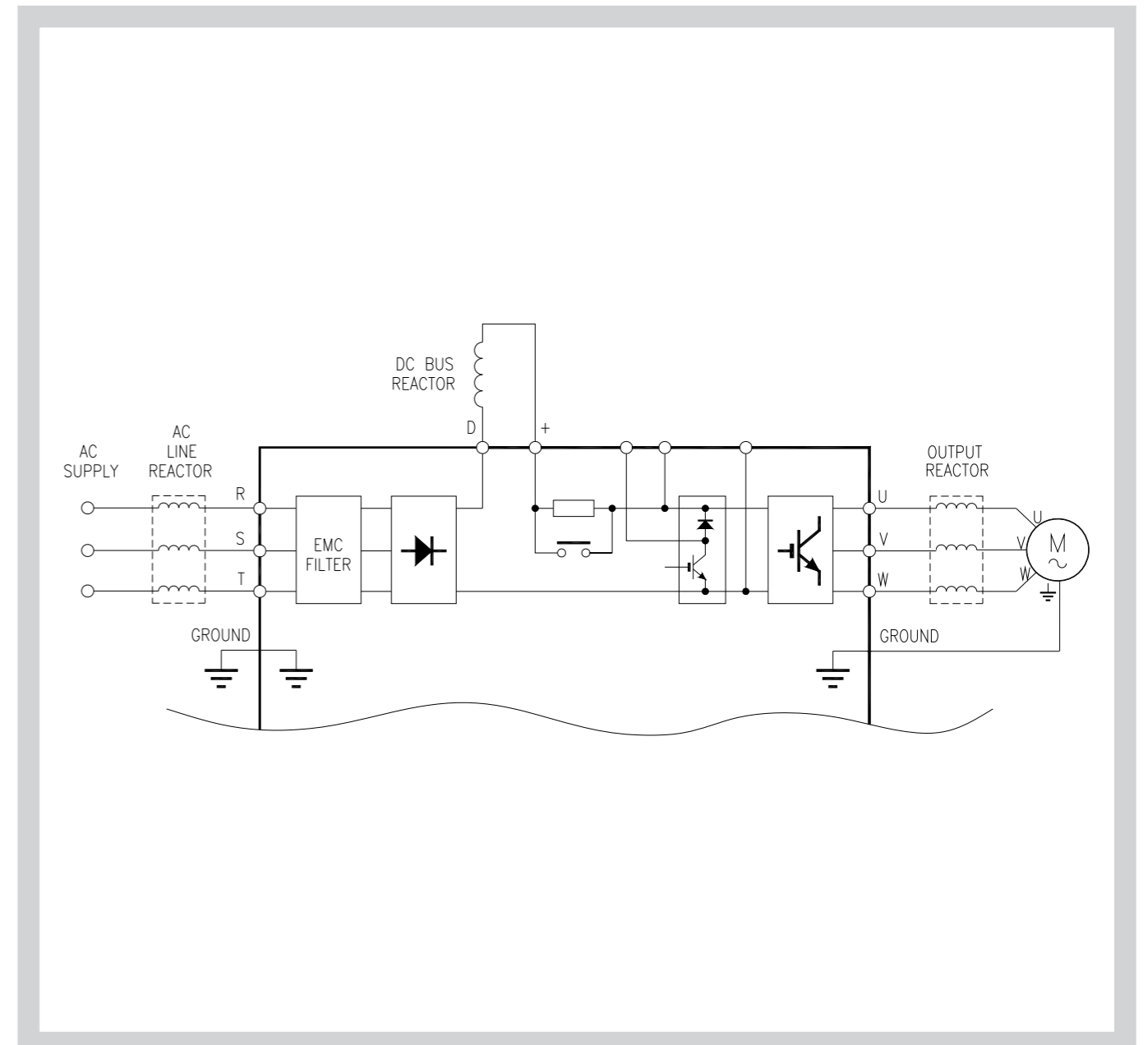

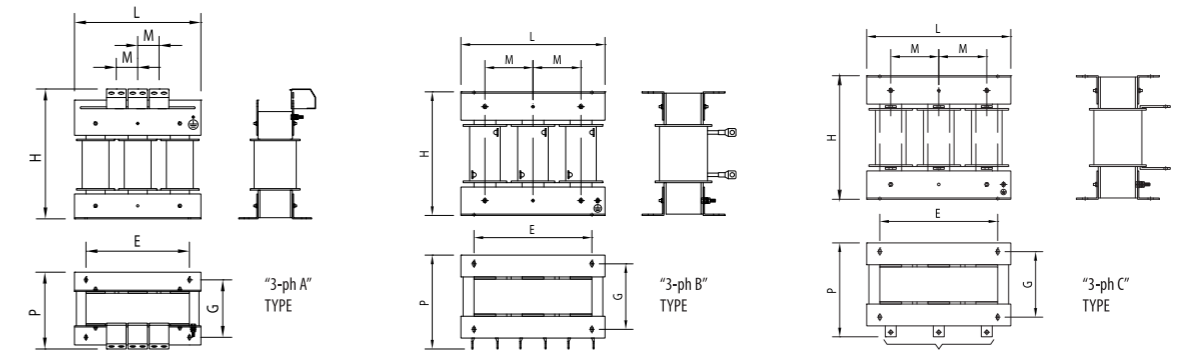
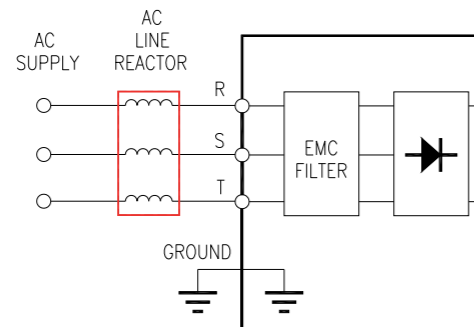

Class 2T – AC Input Inductors

Size	Sinus Penta Model	Input AC 3-phase inductor	Inductance ratings		Max Freq	Dimensions			weight	
	Model		mH	Arms	Hz	Type	W (mm)	H (mm)	D (mm)	Kg
S05	SINUS 0007	IM0126004	2.00	11	60	3-ph A	120	125	75	2.9
	SINUS 0008	IM0126044	1.27	17	60	3-ph A	120	125	75	3
	SINUS 0010									
	SINUS 0015									
	SINUS 0016	IM0126084	0.70	32	60	3-ph B	150	130	115	5.5
	SINUS 0020									
S12	SINUS 0023	IM0126124	0.51	43	60	3-ph B	150	130	115	6
	SINUS 0033	IM0126144	0.30	68	60	3-ph B	180	160	150	9
	SINUS 0037									
S15	SINUS 0040	IM0126164	0.24	92	60	3-ph B	180	160	150	9.5
	SINUS 0049									
S20	SINUS 0060	IM0126204	0.16	142	60	3-ph B	240	210	175	17
	SINUS 0067									
	SINUS 0074									
	SINUS 0086									
S30	SINUS 0113	IM0126244	0.09	252	60	3-ph B	240	210	220	25
	SINUS 0129									
	SINUS 0150									
	SINUS 0162									
	SINUS 0180									
S41	SINUS 0202	IM0126282	0.063	360	60	3-ph C	300	286	205	44
	SINUS 0217	IM0126332	0.050	455	60	3-ph C	300	317	217	54
	SINUS 0260									
	SINUS 0313									
S51	SINUS 0367	IM0126372	0.031	720	60	3-ph C	360	342	268	84
	SINUS 0402	IM0126404	0.023	945	60	3-ph C	360	320	240	67
	SINUS 0457									
S60	SINUS 0524									

Class 4T – AC Input Inductors

Size	Sinus Penta Model	Input AC 3-phase inductor	Inductance ratings		Max Freq	Dimensions			weight	
	Model		mH	Arms	Hz	Type	W (mm)	H (mm)	D (mm)	Kg
S05	SINUS 0005	IM0126004	2.00	11	60	3-ph A	120	125	75	2.9
	SINUS 0007	IM0126044	1.27	17	60	3-ph A	120	125	75	3.0
	SINUS 0009									
	SINUS 0011									
	SINUS 0014	IM0126084	0.70	32	60	3-ph B	150	130	115	5.5
	SINUS 0016									
S12	SINUS 0017	IM0126124	0.51	43	60	3-ph B	150	130	115	6.0
	SINUS 0020									
	SINUS 0025	IM0126144	0.30	68	60	3-ph B	180	160	150	9.0
	SINUS 0030									
	SINUS 0034									
SINUS 0036										
S15	SINUS 0040	IM0126164	0.24	92	60	3-ph B	180	160	150	9.5
	SINUS 0049									
	SINUS 0060									
	SINUS 0067									
S20	SINUS 0074	IM0126204	0.16	142	60	3-ph B	240	210	175	17
	SINUS 0086									
	SINUS 0113									
	SINUS 0129									
	SINUS 0150									
S30	SINUS 0162	IM0126244	0.09	252	60	3-ph B	240	210	220	25
	SINUS 0180									
	SINUS 0202									
	SINUS 0217									
	SINUS 0260									
S41	SINUS 0313	IM0126282	0.063	360	60	3-ph C	300	286	205	44
	SINUS 0367	IM0126332	0.050	455	60	3-ph C	300	317	217	54
	SINUS 0402									
	SINUS 0457									
S51	SINUS 0524	IM0126372	0.031	720	60	3-ph C	360	342	268	84
S60	SINUS 0598P	IM0126404	0.023	945	60	3-ph C	300	320	240	67
	SINUS 0598									
	SINUS 0748									
S65	SINUS 0831	IM0126444	0.018	1260	60	3-ph C	360	375	280	82
S75	SINUS 0964	2 x IM0126404	0.023	945	60	3-ph C	300	320	240	67
	SINUS 1130									
S90	SINUS 1296	2 x IM0126444	0.018	1260	60	3-ph C	360	375	280	82
	SINUS 1800	3 x IM0126404	0.023	945	60	3-ph C	300	320	240	67
	SINUS 2076									

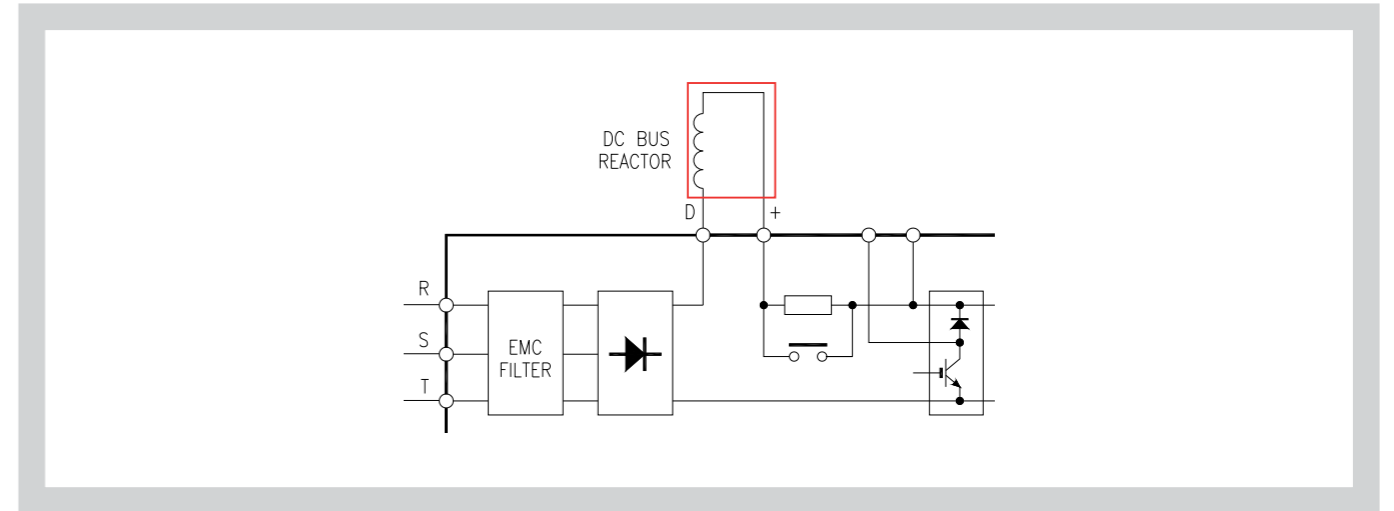

Class 5T-6T – AC Input Inductors

Size	Sinus Penta Model	Input AC 3-phase inductor	Inductance ratings		Max Freq	Dimensions			weight					
			mH	Arms	Hz	Type	W (mm)	H (mm)		D (mm)	Kg			
S12 5T S14 6T	SINUS 0003	IM0127042	6.4	6.5	60	Please contact Elettronica Santerno								
	SINUS 0004	IM0127062	4.1	10.5	60									
	SINUS 0006	IM0127082	2.6	16	60									
S14	SINUS 0012	IM0127102	1.8	23	60									
	SINUS 0018	IM0127122	1.1	40	60									
	SINUS 0021	IM0127142	0.70	57	60									
S22	SINUS 0019	IM0127167	0.43	95	60					3-ph B	240	224	187	27
	SINUS 0022	IM0127202	0.29	140	60					3-ph B	300	254	190	35
	SINUS 0024	IM0127227	0.19	210	60					3-ph B	300	285	218	48
S32	SINUS 0032	IM0127274	0.12	325	60					3-ph C	300	286	234	60
	SINUS 0042	IM0127330	0.096	415	60					3-ph C	360	340	250	80
	SINUS 0051	IM0127350	0.061	650	60					3-ph C	360	411	298	113
S42	SINUS 0062	IM0127404	0.040	945	60					3-ph C	360	385	260	88
	SINUS 0069	IM0127444	0.030	1260	60					3-ph C	420	440	290	110
	SINUS 0076	2 x IM0127364	0.058	662	60					3-ph C	360	310	275	79
S52	SINUS 0088	2 x IM0127404	0.040	945	60	3-ph C	360	385	260	88				
	SINUS 0131	2 x IM0127444	0.030	1260	60	3-ph C	420	440	290	110				
	SINUS 0164	3 x IM0127404	0.040	945	60	3-ph C	360	385	260	88				
S70	SINUS 0181	3 x IM0127444	0.030	1260	60	3-ph C	420	440	290	110				
	SINUS 0201	3 x IM0127404	0.040	945	60	3-ph C	360	385	260	88				
	SINUS 0218	3 x IM0127444	0.030	1260	60	3-ph C	420	440	290	110				
S75	SINUS 0259	3 x IM0127404	0.040	945	60	3-ph C	360	385	260	88				
	SINUS 0290	3 x IM0127444	0.030	1260	60	3-ph C	420	440	290	110				
	SINUS 0314	3 x IM0127444	0.030	1260	60	3-ph C	420	440	290	110				
S80	SINUS 0368	3 x IM0127444	0.030	1260	60	3-ph C	420	440	290	110				
	SINUS 0401	3 x IM0127444	0.030	1260	60	3-ph C	420	440	290	110				
	SINUS 0457	3 x IM0127444	0.030	1260	60	3-ph C	420	440	290	110				
S90	SINUS 0524	3 x IM0127444	0.030	1260	60	3-ph C	420	440	290	110				
	SINUS 0524	3 x IM0127444	0.030	1260	60	3-ph C	420	440	290	110				
	SINUS 0524	3 x IM0127444	0.030	1260	60	3-ph C	420	440	290	110				

Class 2T – DC Inductors

Size	Sinus Penta Model	DC inductor	Inductance ratings		Dimensions			weight	
			mH	Arms	Type	W (mm)	H (mm)		D (mm)
S05	SINUS 0007	IM0140054	8.0	10.5	DC - A	110	125	100	4.5
	SINUS 0008	IM0140104	5.1	17	DC - A	110	125	100	5
	SINUS 0010	IM0140154	2.8	32.5	DC - A	120	140	160	8
S12	SINUS 0015	IM0140204	2.0	47	DC - A	160	240	160	12
	SINUS 0016	IM0140254	1.2	69	DC - A	160	240	160	13
	SINUS 0020	IM0140284	0.96	100	DC - A	170	240	205	21
S15	SINUS 0023	IM0140304	0.64	160	DC - A	240	260	200	27
	SINUS 0033	IM0140404	0.36	275	DC - A	260	290	200	35
	SINUS 0037	IM0140454	0.18	420	DC - B	240	380	220	49
S20	SINUS 0040	IM0140604	0.14	520	DC - B	240	380	235	57
	SINUS 0049	IM0140664	0.090	830	DC - B	260	395	270	75
	SINUS 0060	IM0140754	0.092	1040	DC - C	310	470	320	114
S20	SINUS 0067	IM0140754	0.092	1040	DC - C	310	470	320	114
	SINUS 0074	IM0140754	0.092	1040	DC - C	310	470	320	114
	SINUS 0086	IM0140754	0.092	1040	DC - C	310	470	320	114
S30	SINUS 0113	IM0140754	0.092	1040	DC - C	310	470	320	114
	SINUS 0129	IM0140754	0.092	1040	DC - C	310	470	320	114
	SINUS 0150	IM0140754	0.092	1040	DC - C	310	470	320	114
S41	SINUS 0180	IM0140754	0.092	1040	DC - C	310	470	320	114
	SINUS 0202	IM0140754	0.092	1040	DC - C	310	470	320	114
	SINUS 0217	IM0140754	0.092	1040	DC - C	310	470	320	114
S51	SINUS 0260	IM0140754	0.092	1040	DC - C	310	470	320	114
	SINUS 0313	IM0140754	0.092	1040	DC - C	310	470	320	114
	SINUS 0367	IM0140754	0.092	1040	DC - C	310	470	320	114
S60	SINUS 0402	IM0140754	0.092	1040	DC - C	310	470	320	114
	SINUS 0457	IM0140754	0.092	1040	DC - C	310	470	320	114
	SINUS 0524	IM0140754	0.092	1040	DC - C	310	470	320	114

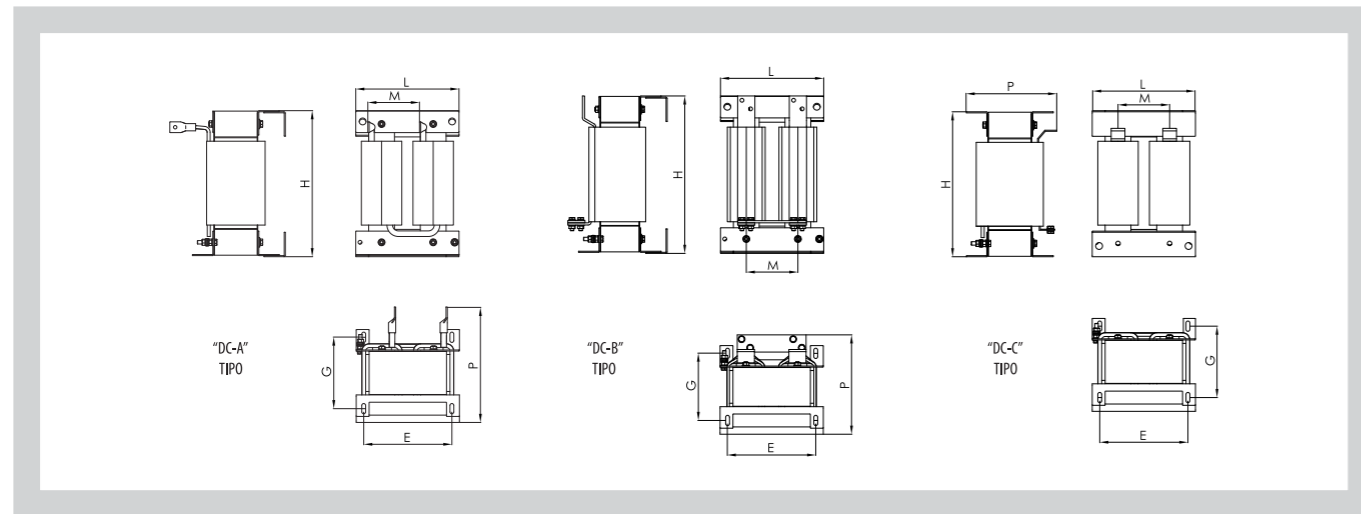

Class 4T – DC Inductors

Size	Sinus Penta Model	Input AC 3-phase inductor	Inductance ratings			Dimensions			weight
			mH	Arms	Type	W (mm)	H (mm)	D (mm)	
S05	SINUS 0005				Non applicabile				
	SINUS 0007								
	SINUS 0009								
	SINUS 0011								
	SINUS 0014								
S12	SINUS 0016	IM0140154	2.8	32.5	DC-A	120	140	160	8
	SINUS 0017	IM0140204	2.0	47	DC-A	160	240	160	12
	SINUS 0020								
	SINUS 0025	IM0140254	1.2	69	DC-A	160	240	160	13
	SINUS 0034								
SINUS 0036									
S15	SINUS 0040	IM0140284	0.96	100	DC-A	170	240	205	21
	SINUS 0049								
S20	SINUS 0060	IM0140304	0.64	160	DC-A	240	260	200	27
	SINUS 0067								
	SINUS 0074								
	SINUS 0086								
S30	SINUS 0113	IM0140404	0.36	275	DC-A	260	290	200	35
	SINUS 0129								
	SINUS 0150								
	SINUS 0162								
S41	SINUS 0180	IM0140454	0.18	420	DC-B	240	380	220	49
	SINUS 0202								
	SINUS 0217	IM0140604	0.14	520	DC-B	240	380	235	57
	SINUS 0260								
S51	SINUS 0313	IM0140664	0.090	830	DC-B	260	395	270	75
	SINUS 0367								
S60	SINUS 0402	IM0140754	0.092	1040	DC-C	310	470	320	114
	SINUS 0457								
S60P	SINUS 0524	IM0140754	0.092	1040	DC-C	310	470	320	114
	SINUS 0598P								
S65	SINUS 0598	IM0140854	0.072	1470	DC-C	330	540	320	152
	SINUS 0748								
	SINUS 0831								
S75	SINUS 0964	2 x IM0140754	0.092	1040	DC-C	310	470	320	114
	SINUS 1130								
	SINUS 1296	3 x IM0140754	0.092	1040	DC-C	310	470	320	114
S90	SINUS 1800	3 x IM0140854	0.092	1040	DC-C	310	470	320	114
	SINUS 2076								

Class 5T-6T – DC Inductors

Size	Sinus Penta Model	Input AC 3-phase inductor	Inductance ratings			Dimensions			weight
			mH	Arms	Type	W (mm)	H (mm)	D (mm)	
S12 5T S14 6T	SINUS 0003				Please contact Elettronica Santerno				
	SINUS 0004								
	SINUS 0006								
	SINUS 0012								
	SINUS 0018								
S14	SINUS 0019				Please contact Elettronica Santerno				
	SINUS 0021								
	SINUS 0022								
	SINUS 0024								
S22	SINUS 0032	IM0141404	1.2	110	DC-A	170	205	205	21
	SINUS 0042								
	SINUS 0051								
S32	SINUS 0062	IM0141414	0.80	160	DC-A	200	260	215	27
	SINUS 0069								
	SINUS 0076								
	SINUS 0088								
S42	SINUS 0131	IM0141424	0.66	240	DC-A	240	340	260	53
	SINUS 0164								
	SINUS 0181	IM0141434	0.32	375	DC-B	240	380	235	56
	SINUS 0201								
S52	SINUS 0218	IM0141554	0.27	475	DC-B	240	380	265	66
	SINUS 0259								
	SINUS 0290								
	SINUS 0314	IM0141664	0.17	750	DC-B	260	395	295	90
	SINUS 0368								
S65	SINUS 0401	IM0141804	0.16	1170	DC-C	350	630	360	230
	SINUS 0457								
	SINUS 0524								
S70	SINUS 0598	IM0141904	0.12	1290	DC-C	350	630	360	230
	SINUS 0748								
S75	SINUS 0831	2 x IM0141704	0.232	830	DC-C	330	550	340	163
	SINUS 0964								
S80	SINUS 1130	2 x IM0141804	0.16	1170	DC-C	350	630	360	230
	SINUS 1296								
	SINUS 1800	3 x IM0141804	0.16	1170	DC-C	350	630	360	230
S90	SINUS 2076	3 x IM0141904	0.12	1290	DC-C	350	630	360	230
	SINUS 1800								

Output Inductors (du/dt filters)

Installations requiring cable lengths over 100m between the inverter and the motor may cause overcurrent protections to frequently trip. This is due to the wire parasite capacity generating current pulses at the inverter output; those current pulses are generated from the high du/dt ratio of the inverter output voltage. The current pulses may be limited by an inductor installed on the inverter Woutput. Shielded cables even have a higher capacity and may cause problems with shorter cable lengths. An adverse effect can also be the stress produced on the motor insulation due to the high du/dt ratio at the inverter output.

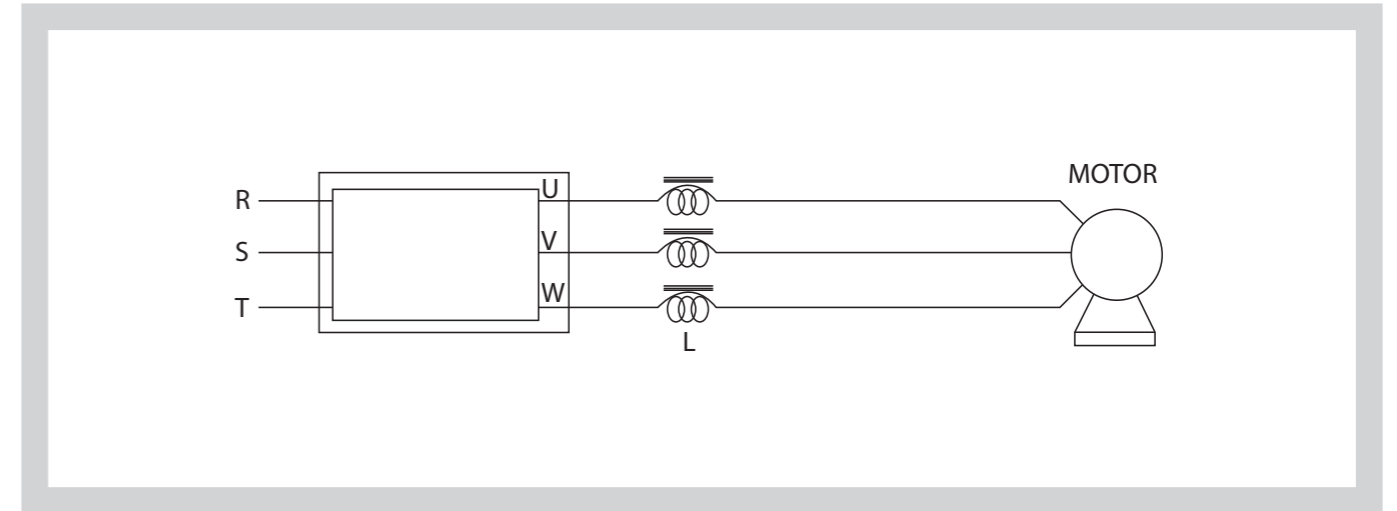
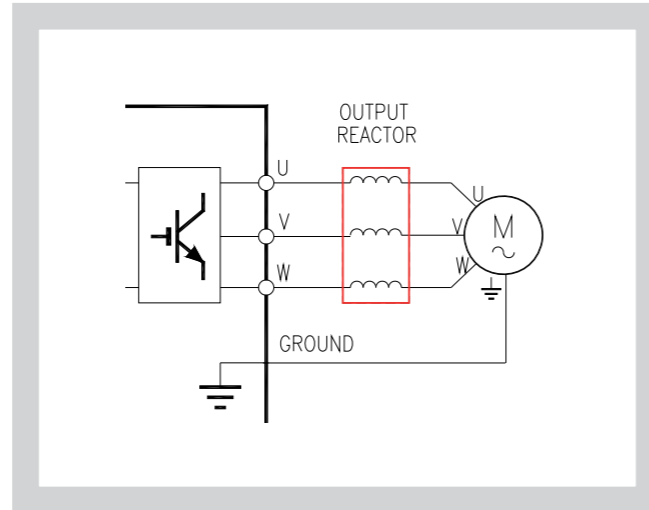

Class 2T – AC Output Inductors

Size	Sinus Penta Model	Input AC 3-phase inductor	Inductance ratings		Max Freq Hz	Dimensions			weight Kg	
	Model		mH	Arms		Type	W (mm)	H (mm)		D (mm)
S05	SINUS 0007	IM0126004	2.00	11	60	3-ph A	120	125	75	2.9
	SINUS 0008	IM0126044	1.27	17	60	3-ph A	120	125	75	3
	SINUS 0010									
	SINUS 0015									
	SINUS 0016	IM0126084	0.70	32	60	3-ph B	150	130	115	5.5
S12	SINUS 0020	IM0126124	0.51	43	60	3-ph B	150	130	115	6
	SINUS 0023									
	SINUS 0033									
S15	SINUS 0037	IM0126144	0.30	68	60	3-ph B	180	160	150	9
	SINUS 0040	IM0126164	0.24	92	60	3-ph B	180	160	150	9.5
SINUS 0049										
S20	SINUS 0060	IM0126204	0.16	142	60	3-ph B	240	210	175	17
	SINUS 0067									
	SINUS 0074									
	SINUS 0086									
S30	SINUS 0113	IM0126244	0.09	252	60	3-ph B	240	210	220	25
	SINUS 0129									
	SINUS 0150									
	SINUS 0162									
S41	SINUS 0180	IM0138200	0.07	360	120	DU/DT B	360	401	269	77
	SINUS 0202	IM0138250	0.035	440	120	DU/DT B	360	401	269	75
	SINUS 0217									
	SINUS 0260									
S51	SINUS 0313	IM0138300	0.025	700	120	DU/DT B	360	401	269	93
	SINUS 0367	IM0126404	0.023	945	60	3-ph C	300	320	240	67
	SINUS 0402									
S60	SINUS 0457									
S60P	SINUS 0524									

Class 4T – AC Output Inductors

Size	Sinus Penta Model	Input AC 3-phase inductor	Inductance ratings		Max Freq Hz	Dimensions			weight Kg	
	Model		mH	Arms		Type	W (mm)	H (mm)		D (mm)
S05	SINUS 0005	IM0126004	2.00	11	60	3-ph A	120	125	75	2.9
	SINUS 0007	IM0126044	1.27	17	60	3-ph A	120	125	75	3.0
	SINUS 0009									
	SINUS 0011									
	SINUS 0014	IM0126084	0.70	32	60	3-ph B	150	130	115	5.5
S12	SINUS 0016	IM0126124	0.51	43	60	3-ph B	150	130	115	6.0
	SINUS 0017									
	SINUS 0020									
	SINUS 0025									
S15	SINUS 0030	IM0126144	0.30	68	60	3-ph B	180	160	150	9.0
	SINUS 0034	IM0126164	0.24	92	60	3-ph B	180	160	150	9.5
	SINUS 0036									
S20	SINUS 0040	IM0126204	0.16	142	60	3-ph B	240	210	175	17
	SINUS 0049									
	SINUS 0060									
	SINUS 0067									
S30	SINUS 0074	IM0126244	0.09	252	60	3-ph B	240	210	220	25
	SINUS 0086									
	SINUS 0113									
	SINUS 0129									
S41	SINUS 0150	IM0138200	0.07	360	120	DU/DT - B	360	401	269	77
	SINUS 0162									
	SINUS 0180									
	SINUS 0202									
S51	SINUS 0217	IM0138250	0.035	440	120	DU/DT - B	360	401	269	75
	SINUS 0260	IM0138300	0.025	700	120	DU/DT - B	360	401	269	93
	SINUS 0313									
S60	SINUS 0367	IM0126404	0.023	945	60	3-ph C	300	320	240	67
	SINUS 0402									
S65	SINUS 0457									
S75	SINUS 0524	6 x IM0141782	0.015	1250	60	Single-Phase	260	430	385	100
	SINUS 0598P									
S90	SINUS 0598	9 x IM0141782	0.015	1250	60	Single-Phase	260	430	385	100
	SINUS 0748									
S90	SINUS 0831	IM0126444	0.018	1260	60	3-ph C	360	375	280	82
	SINUS 0964									

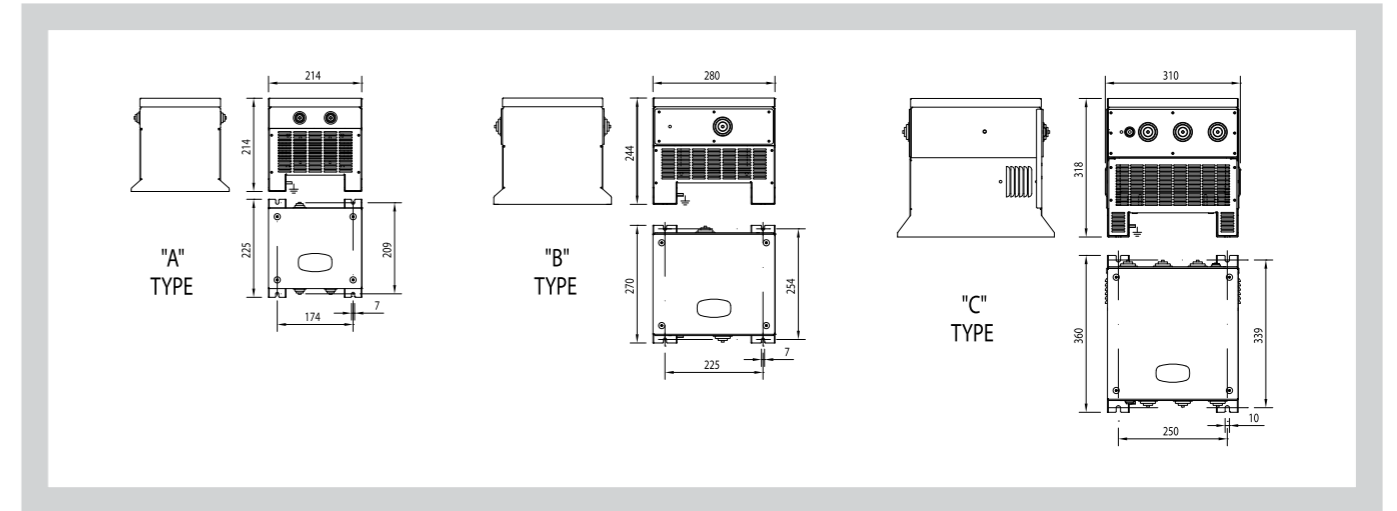
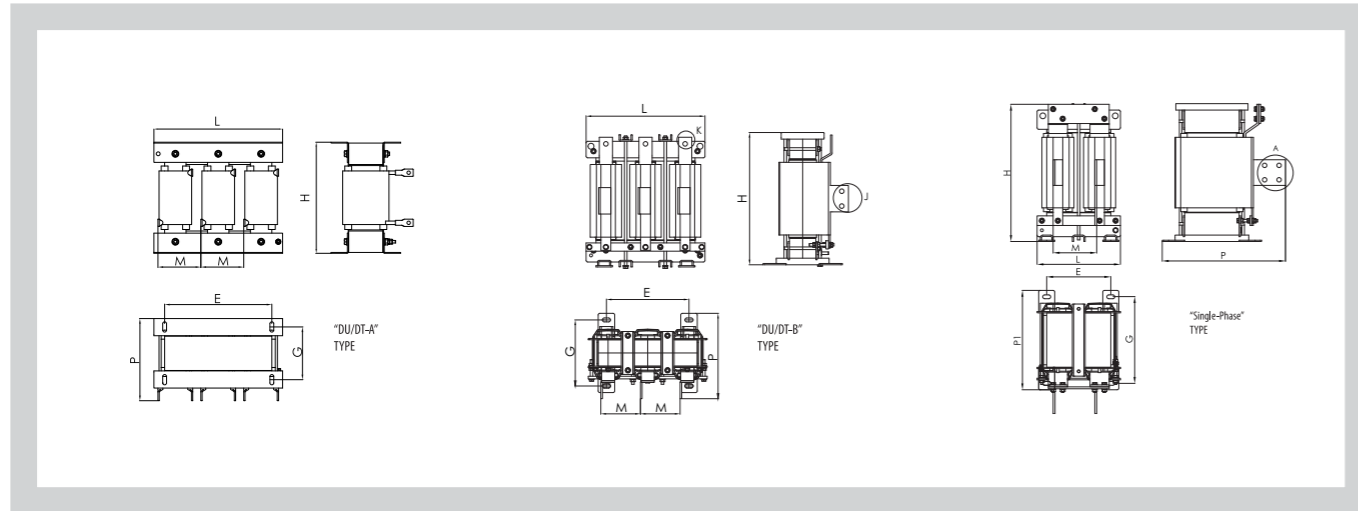

Class 5T-6T – AC Output Inductors

Size	Sinus Penta Model	Input AC 3-phase inductor	Inductance ratings		Max Freq	Dimensions			weight					
			mH	Arms		Type	W (mm)	H (mm)		D (mm)	Kg			
S12 5T S14 6T	SINUS 0003 SINUS 0004 SINUS 0006	IM0138000	1.5	9.5	120	Please contact Elettronica Santerno								
	SINUS 0012 SINUS 0018	IM0138010	1.0	14	120									
	SINUS 0019 SINUS 0021	IM0138020	0.80	18.5	120									
	SINUS 0022 SINUS 0024 SINUS 0032	IM0138030	0.60	27	120									
	SINUS 0042	IM0138040	0.42	43	120									
S22	SINUS 0042	IM0138045	0.28	65	120									
	SINUS 0051 SINUS 0062 SINUS 0069	IM0138050	0.17	105	120					DU/DT A	300	259	192	39
	SINUS 0076 SINUS 0088	IM0138100	0.11	165	120					DU/DT A	300	258	198	42
S32	SINUS 0131 SINUS 0164	IM0138150	0.075	240	120					DU/DT A	300	321	208	52
	SINUS 0181 SINUS 0201	IM0138200	0.070	360	120					DU/DT B	360	401	269	77
	SINUS 0218 SINUS 0259	IM0138250	0.035	440	120					DU/DT B	360	401	268	75
S52	SINUS 0290 SINUS 0314 SINUS 0368	IM0138300	0.025	700	120					DU/DT B	360	411	279	93
	SINUS 0401 SINUS 0457	IM0127404	0.040	945	60					DU/DT C	360	385	260	88
	SINUS 0524 SINUS 0598													
SINUS 0748														
S70	SINUS 0831	IM0127444	0.030	1260	60	DU/DT C	420	440	290	110				
S75	SINUS 0964	6 x IM0141782	0.015	1250	60	Single-Phase	260	430	385	100				
S80	SINUS 1130													
S90	SINUS 1296	9 x IM0141782	0.015	1250	60	Single-Phase	260	430	385	100				
	SINUS 1800 SINUS 2076													

Class 2T - INPUT-OUTPUT 3-Phase AC Inductors in IP54 enclosure

Size	Sinus Penta model	Inductor model	Use	Mechanical dimensions	Weight	Losses
				Type		
S05	SINUS 0007 SINUS 0008 SINUS 0010 SINUS 0015	ZZ0112020	Input-output	A	7	48
	SINUS 0016 SINUS 0020	ZZ0112030	Input-output	A	9.5	70
	SINUS 0023 SINUS 0033	ZZ0112040	Input-output	A	10	96
	SINUS 0037	ZZ0112045	Input-output	B	14	150
	SINUS 0040 SINUS 0049	ZZ0112050	Input-output	B	14.5	183
S20	SINUS 0060 SINUS 0067 SINUS 0074 SINUS 0086	ZZ0112060	Input-output	C	26	272
	SINUS 0113 SINUS 0129 SINUS 0150 SINUS 0162	ZZ0112070	Input-output	C	32.5	342

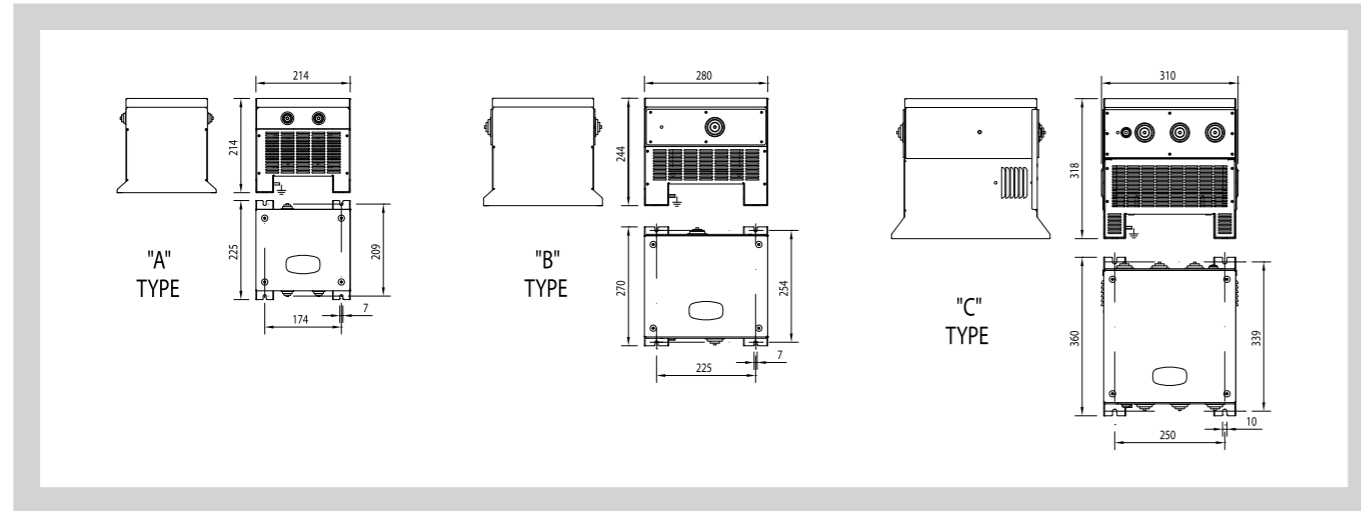

Class 5T-6T - INPUT 3-Phase AC Inductors in IP54 enclosure

Size	Sinus Penta model	Inductor model	Use	Mechanical dimensions	Weight	Losses
				Type	kg	W
S12 5T S14 6T	SINUS 0003	ZZ0112110	Input only	Please contact Elettronica Santerno		
	SINUS 0004	ZZ0112120	Input only			
	SINUS 0006	ZZ0112130	Input only			
	SINUS 0012	ZZ0112130	Input only			
S14	SINUS 0018	ZZ0112130	Input only			
	SINUS 0019	ZZ0112140	Input only			
	SINUS 0021	ZZ0112140	Input only			
	SINUS 0022	ZZ0112150	Input only			
S22	SINUS 0024	ZZ0112150	Input only			
	SINUS 0032	ZZ0112160	Input only			
	SINUS 0042	ZZ0112160	Input only			
	SINUS 0051	ZZ0112170	Input only			
S32	SINUS 0062	ZZ0112170	Input only			
	SINUS 0069	ZZ0112170	Input only			
	SINUS 0076	ZZ0112180	Input only			
	SINUS 0088	ZZ0112180	Input only			
	SINUS 0131	ZZ0112190	Input only			
	SINUS 0164	ZZ0112190	Input only			

Class 4T - INPUT-OUTPUT 3-Phase AC Inductors in IP54 enclosure

Size	Sinus Penta model	Inductor model	Use	Mechanical dimensions	Weight	Losses
				Type	kg	W
S05	SINUS 0005	ZZ0112010	Input-output	A	6.5	29
	SINUS 0007	ZZ0112020	Input-output	A	7	48
	SINUS 0009					
	SINUS 0011					
	SINUS 0014					
S12	SINUS 0016	ZZ0112030	Input-output	A	9.5	70
	SINUS 0017					
	SINUS 0020					
	SINUS 0025	ZZ0112040	Input-output	A	10	96
	SINUS 0030	ZZ0112045	Input-output	B	14	150
	SINUS 0034					
SINUS 0036						
S15	SINUS 0040	ZZ0112050	Input-output	B	14.5	183
SINUS 0049						
S20	SINUS 0060	ZZ0112060	Input-output	C	26	272
	SINUS 0067					
	SINUS 0074					
	SINUS 0086					
S30	SINUS 0113	ZZ0112070	Input-output	C	32.5	342
	SINUS 0129					
	SINUS 0150					
	SINUS 0162					

Class 5T-6T - OUTPUT 3-Phase AC Inductors in IP54 enclosure

Size	Sinus Penta model	Inductor model	Use	Mechanical dimensions	Weight	Losses
				Type	kg	W
S12 5T S14 6T	SINUS 0003	ZZ0112115	Output only	Please contact Elettronica Santerno		
	SINUS 0004					
	SINUS 0006					
	SINUS 0012					
S14	SINUS 0018	ZZ0112125	Output only			
	SINUS 0019	ZZ0112135	Output only			
	SINUS 0021	ZZ0112145	Output only			
	SINUS 0022	ZZ0112155	Output only			
S22	SINUS 0024	ZZ0112155	Output only			
	SINUS 0032	ZZ0112165	Output only			
	SINUS 0042	ZZ0112165	Output only			
	SINUS 0051	ZZ0112175	Output only			
S32	SINUS 0062	ZZ0112175	Output only			
	SINUS 0069	ZZ0112175	Output only			
	SINUS 0076	ZZ0112185	Output only			
	SINUS 0088	ZZ0112185	Output only			
	SINUS 0131	ZZ0112195	Output only			
	SINUS 0164	ZZ0112195	Output only			

BRAKING UNITS AND RESISTORS



Perfect Match of SINUS PENTA, Drive, Braking Unit, Resistors

SINUS PENTA drives have integrated braking unit up to size S32
 Specific external braking units are available from size S41 to S90
 Santerno offers a complete set of resistors for each specific application

BRAKING UNITS AND RESISTORS

Configurations



INTEGRATED Braking Unit in SINUS PENTA DRIVE S05-S32

All SINUS PENTA DRIVES up to S32 have an integrated Braking Unit.



BU200 for S60 - S60P

BU200 is the specific external Braking Unit for size S60
 (BU200 may be used instead of BU700 also for S41-S51)



BU700 2T-4T for S41-S51 - BU600 5T-6T for S42-S52

BU700 is the specific external Braking Unit for 2T-4T size S41-S51
 BU600 is the specific external Braking Unit for 5T-6T size S42-S52



BU1440 for Modular Inverter S65-S90

BU1440 is the modular Braking Unit for all modular inverters:
 S65,S70,S75,S80,S90

BRAKING UNITS AND RESISTORS

Type of connection

- A-** One resistor
- B-** Two or more parallel-connected resistors
- D-** Four resistors (parallel connection of two series of two resistors)
- C-** Two series-connected resistors
- D-** Four resistors (parallel-connection of two series of two resistors)
- E-** Six resistors (parallel-connection of three series of two resistors)
- F-** Eight resistors (parallel-connection of four series of two resistors)
- M-** Two units, each of them including a braking module connected to its braking resistor
- MD-** Two units, each of them including a braking module connected to four braking resistors (parallel-connection of two series of two resistors)
- ME-** Two units, each of them including a braking module connected to six braking resistors (parallel-connection of three series of two resistors)
- MF-** Two units, each of them including a braking module connected to eight braking resistors (parallel-connection of four series of two resistors)
- MG-** Two units, each of them including a braking module connected to ten braking resistors (parallel-connection of five series of two resistors)
- MH-** Two units, each of them including a braking module connected to twelve braking resistors (parallel-connection of six series of two resistors)
- N-** Three units, each of them including a braking module connected to its braking resistor
- O-** Four units, each of them including a braking module connected to its braking resistor
- P-** Five units, each of them including a braking module connected to its braking resistor
- Q-** Six units, each of them including a braking module connected to its braking resistor
- R-** Seven units, each of them including a braking module connected to its braking resistor
- S-** Eight units, each of them including a braking module connected to its braking resistor
- V-** Two units, each of them including a braking module connected to two parallel-connected braking resistors
- X-** Three units, each of them including a braking module connected to two parallel-connected braking resistors
- Y-** Four units, each of them including a braking module connected to two parallel-connected braking resistors
- W-** Five units, each of them including a braking module connected to two parallel-connected braking resistors
- Z-** Six units, each of them including a braking module connected to two parallel-connected braking resistors

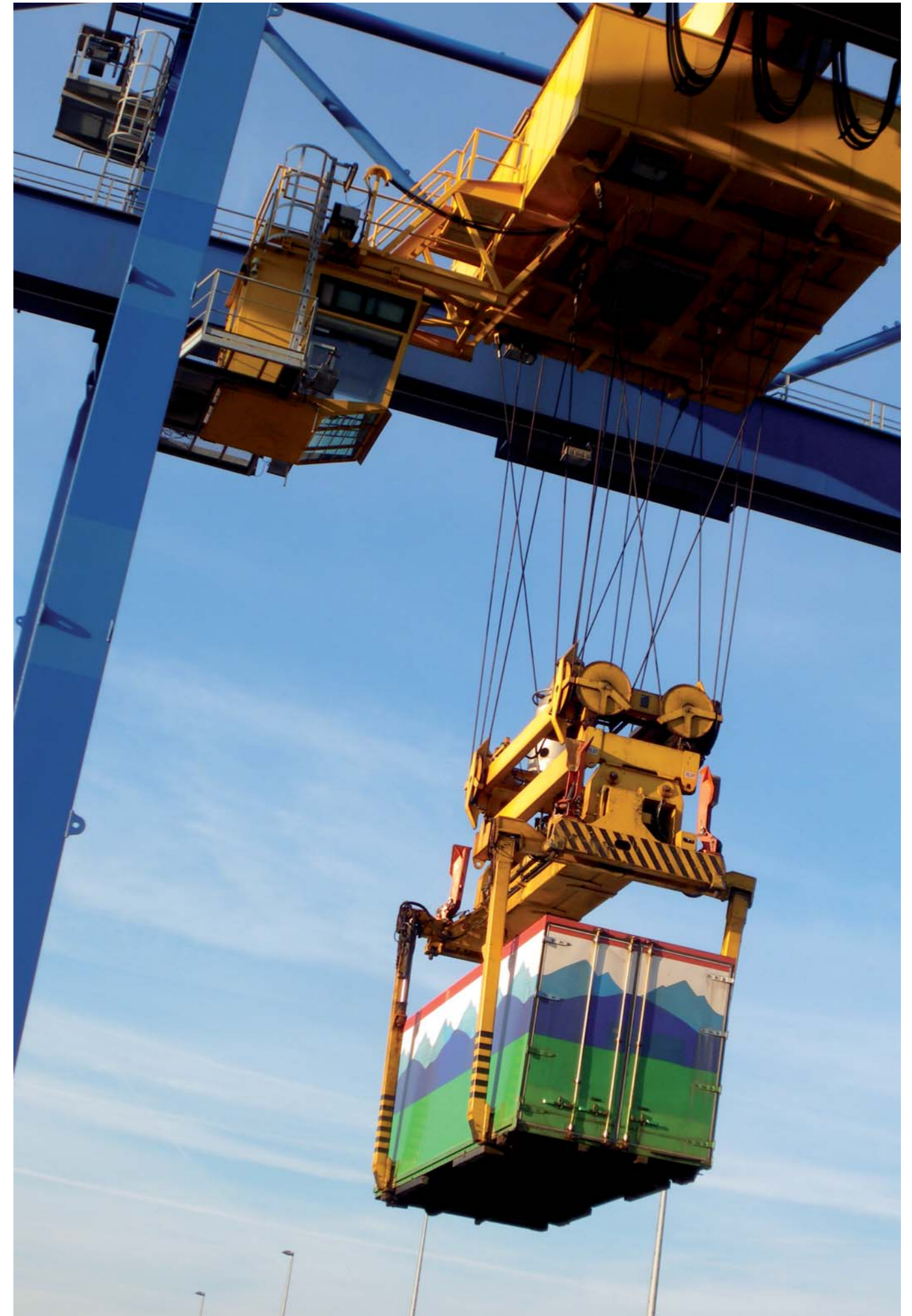

BRAKING RESISTORS FOR S05-S30 - 2T

Applications with DUTY CYCLE 10% - Class 2T

Inverter			Braking resistors						
Size	Sinus Penta model	Min. Applicable resistor (Ω)	Part number	Number of resistors	Type	Degree of protection	Type of connection	Value	Wire cross section
								(Ω)	mm ² (AWG)
S05	SINUS 0007	25.0	RE2643560	1	56Ω-350W	IP55	A	56	2.5(14)
	SINUS 0008	25.0			2*56Ω-350W	IP55	B	28	2.5(14)
	SINUS 0010	25.0		2	2*56Ω-350W	IP55	B	28	2.5(14)
	SINUS 0013	18.0			2*56Ω-350W	IP55	B	28	2.5(14)
	SINUS 0015	18.0			2*56Ω-350W	IP55	B	28	2.5(14)
	SINUS 0016	18.0		3	3*56Ω-350W	IP55	B	18.7	2.5(14)
	SINUS 0020	18.0			3*56Ω-350W	IP55	B	18.7	2.5(14)
S12	SINUS 0023	15.0	RE3083150	1	15Ω-1100W	IP55	A	15	4(12)
	SINUS 0033	10.0	RE3093100	1	10Ω-1500W	IP54	A	10	4(12)
	SINUS 0037	10.0			10Ω-1500W	IP54	A	10	4(12)
S15	SINUS 0040	7.5	RE3083150	1	2*15Ω-1100W	IP55	A	7.5	4(12)
	SINUS 0049	5.0	RE3482500	1	5Ω-4000W	IP20	A	5.0	10(8)
SINUS 0060	5.0	5Ω-4000W			IP20	A	5.0	10(8)	
SINUS 0067	5.0	5Ω-4000W			IP20	A	5.0	10(8)	
SINUS 0074	4.2	5Ω-4000W			IP20	A	5.0	10(8)	
S20	SINUS 0086	4.2	RE3762330	1	5Ω-4000W	IP20	A	5.0	10(8)
	SINUS 0113	3.0			3,3Ω-8000W	IP20	A	3.3	10(8)
	SINUS 0129	3.0			3,3Ω-8000W	IP20	A	3.3	10(8)
	SINUS 0150	2.5			3,3Ω-8000W	IP20	A	3.3	10(8)
SINUS 0162	2.5				3,3Ω-8000W	IP20	A	3.3	10(8)

Type of connection:
A-One resistor
B-Two or multiple parallel-connected resistors

Applications with DUTY CYCLE 20% - Class 2T

Inverter			Braking resistors						
Size	Sinus Penta model	Min. Applicable resistor (Ω)	Part number	Number of resistors	Type	Degree of protection	Type of connection	Value	Wire cross section
								(Ω)	mm ² (AWG)
S05	SINUS 0007	25.0	RE2644100	2	2*100Ω-350W	IP55	B	50	2.5(14)
	SINUS 0008	25.0	RE2643560	2	2*56Ω-350W	IP55	B	28	2.5(14)
	SINUS 0010	25.0			2*56Ω-350W	IP55	B	28	2.5(14)
	SINUS 0013	18.0	RE2644100	4	4*100Ω-350W	IP55	B	25	2.5(14)
	SINUS 0015	18.0			4*100Ω-350W	IP55	B	25	2.5(14)
	SINUS 0016	18.0	RE3103250	1	25Ω-1800W	IP54	A	25	2.5(14)
SINUS 0020	18.0	25Ω-1800W			IP54	A	25	2.5(14)	
S12	SINUS 0023	15.0	RE3113150	1	15Ω-2200W	IP54	A	15	4(12)
	SINUS 0033	10.0	RE3103250	2	2*25Ω-1800W	IP54	B	12.5	2.5(14)
SINUS 0037	10.0	2*25Ω-1800W			IP54	B	12.5	2.5(14)	
S15	SINUS 0040	7.5	RE3113150	2	2*15Ω-2200W	IP54	B	7.5	2.5(14)
	SINUS 0049	5	RE3482500	1	5Ω-4000W	IP20	A	5	6(10)
S20	SINUS 0060	5.0	RE3762500	1	5Ω-8000W	IP20	A	5	10(8)
	SINUS 0067	5.0			5Ω-8000W	IP20	A	5	10(8)
	SINUS 0074	4.2			5Ω-8000W	IP20	A	5	10(8)
	SINUS 0086	4.2			5Ω-8000W	IP20	A	5	10(8)
S30	SINUS 0113	3.0	RE4022330	1	3.3Ω-12000W	IP20	A	3.3	16(6)
	SINUS 0129	3.0			3.3Ω-12000W	IP20	A	3.3	16(6)
	SINUS 0150	2.5			3.3Ω-12000W	IP20	A	3.3	16(6)
	SINUS 0162	2.5			3.3Ω-12000W	IP20	A	3.3	16(6)

Type of connection:
A-One resistor
B-Two or multiple parallel-connected resistors

BRAKING RESISTORS FOR S05-S30 - 2T

Applications with DUTY CYCLE 50% - Class 2T

Inverter			Braking resistors						
Size	Sinus Penta model	Min. Applicable resistor (Ω)	Part number	Number of resistors	Type	Degree of protection	Type of connection	Value	Wire cross section
								(Ω)	mm ² (AWG)
S05	SINUS 0007	25.0	RE3083500	1	50Ω-1100W	IP55	A	50	2.5(14)
	SINUS 0008	25.0	RE3103250	1	25Ω-1800W	IP54	A	25	2.5(14)
	SINUS 0010	25.0			25Ω-1800W	IP54	A	25	2.5(14)
	SINUS 0013	18.0	RE3483250	1	25Ω-4000W	IP20	A	25	2.5(14)
	SINUS 0015	18.0			25Ω-4000W	IP20	A	25	2.5(14)
	SINUS 0016	18.0			25Ω-4000W	IP20	A	25	2.5(14)
	SINUS 0020	18.0	RE3483200	1	20Ω-4000W	IP20	A	20	4(12)
SINUS 0023	15.0	20Ω-4000W			IP20	A	20	6(10)	
S12	SINUS 0033	10.0	RE3763100	1	10Ω-8000W	IP20	A	10	10(8)
	SINUS 0037	10.0			10Ω-8000W	IP20	A	10	10(8)
S15	SINUS 0040	6.6	RE4022660	1	6.6Ω-12000W	IP20	A	6.6	16(6)
	SINUS 0049	6.6			6.6Ω-12000W	IP20	A	6.6	16(6)
S20	SINUS 0060	5.0	RE3763100	2	6.6Ω-12000W	IP20	A	6.6	16(6)
	SINUS 0067	5.0			2*10Ω-8000W	IP20	B	5	10(8)
	SINUS 0074	4.2			2*10Ω-8000W	IP20	B	5	10(8)
	SINUS 0086	4.2			2*10Ω-8000W	IP20	B	5	10(8)
S30	SINUS 0113	3.0	RE4022660	2	2*6.6Ω-12000W	IP20	B	3.3	16(6)
	SINUS 0129	3.0			2*6.6Ω-12000W	IP20	B	3.3	16(6)
	SINUS 0150	2.5	RE4023100	3	3*10Ω-12000W	IP20	B	3.3	10(8)
	SINUS 0162	2.5			3*10Ω-12000W	IP20	B	3.3	10(8)

Type of connection:
A-One resistor
B-Two or multiple parallel-connected resistors

BRAKING RESISTORS FOR S05-S30 - 4T

Applications with DUTY CYCLE 10% - Class 4T

Inverter			Braking resistors						
Size	Sinus Penta model	Min. Applicable resistor (Ω)	Part number	Number of resistors	Type	Degree of protection	Type of connection	Value (Ω)	Wire cross section mm ² (AWG)
S05	SINUS 0005	50	RE3063750	1	75Ω-550W	IP33	A	75	2.5(14)
	SINUS 0007	50			75Ω-550W	IP33	A	75	2.5(14)
	SINUS 0009	50	RE3083500	1	50Ω-1100W	IP55	A	50	2.5(14)
	SINUS 0011	50			50Ω-1100W	IP55	A	50	2.5(14)
	SINUS 0014	50			50Ω-1100W	IP55	A	50	2.5(14)
S12	SINUS 0016	40	RE3093500	1	50Ω-1500W	IP54	A	50	2.5(14)
	SINUS 0017	40			50Ω-1500W	IP54	A	50	2.5(14)
	SINUS 0020	40			50Ω-1500W	IP54	A	50	2.5(14)
	SINUS 0025	20	RE3103250	1	25Ω-1800W	IP54	A	25	4(12)
	SINUS 0030	20			25Ω-1800W	IP54	A	25	4(12)
	SINUS 0034	20	RE3483200	1	20Ω-4000W	IP20	A	20	4(12)
SINUS 0036	20	20Ω-4000W			IP20	A	20	4(12)	
S15	SINUS 0040	15	RE3483150	1	15Ω-4000W	IP20	A	15	6(10)
	SINUS 0049	10			15Ω-4000W	IP20	A	15	6(10)
S20	SINUS 0060	10	RE3763100	1	10Ω-8000W	IP20	A	10	10(8)
	SINUS 0067	10			10Ω-8000W	IP20	A	10	10(8)
	SINUS 0074	7.5			10Ω-8000W	IP20	A	10	10(8)
	SINUS 0086	7.5			10Ω-8000W	IP20	A	10	10(8)
S30	SINUS 0113	6	RE4022660	1	6.6Ω-12000W	IP20	A	6.6	10(8)
	SINUS 0129	6			6.6Ω-12000W	IP20	A	6.6	10(8)
	SINUS 0150	5	RE4162500	1	5Ω-16000W	IP20	A	5	16(6)
	SINUS 0162	5			5Ω-16000W	IP20	A	5	16(6)

Type of connection:
A-One resistor

Applications with DUTY CYCLE 20% - Class 4T

Inverter			Braking resistors						
Size	Sinus Penta model	Min. Applicable resistor (Ω)	Part number	Number of resistors	Type	Degree of protection	Type of connection	Value (Ω)	Wire cross section mm ² (AWG)
S05	SINUS 0005	50	RE3083500	1	50Ω-1100W	IP55	A	50	2.5(14)
	SINUS 0007	50			50Ω-1100W	IP55	A	50	2.5(14)
	SINUS 0009	50			50Ω-1100W	IP55	A	50	2.5(14)
	SINUS 0011	50			50Ω-1500W	IP54	A	50	2.5(14)
	SINUS 0014	50			50Ω-1500W	IP54	A	50	2.5(14)
S12	SINUS 0016	40	RE3113500	1	50Ω-2200W	IP54	A	50	2.5(14)
	SINUS 0017	40			50Ω-2200W	IP54	A	50	2.5(14)
	SINUS 0020	40			50Ω-4000W	IP20	A	50	2.5(14)
	SINUS 0025	20	RE3483250	1	25Ω-4000W	IP20	A	25	6(10)
	SINUS 0030	20			25Ω-4000W	IP20	A	25	6(10)
	SINUS 0034	20	RE3483200	1	20Ω-4000W	IP20	A	20	6(10)
SINUS 0036	20	20Ω-4000W			IP20	A	20	6(10)	
S15	SINUS 0040	15	RE3783150	1	15Ω-8000W	IP23	A	15	10(8)
	SINUS 0049	10			10Ω-12000W	IP20	A	10	10(8)
S20	SINUS 0060	10	RE4053100	1	10Ω-12000W	IP20	A	10	16(6)
	SINUS 0067	10			10Ω-12000W	IP20	A	10	16(6)
	SINUS 0074	7.5	RE4163100	1	10Ω-16000W	IP23	A	10	16(6)
	SINUS 0086	7.5			10Ω-16000W	IP23	A	10	16(6)
S30	SINUS 0113	6	RE3762330	2	2*3.3Ω-8000W	IP20	C	6.6	16(6)
	SINUS 0129	6			2*3.3Ω-8000W	IP20	C	6.6	16(6)
	SINUS 0150	5	RE4023100	2	2*10Ω-12000W	IP20	B	5	16(6)
	SINUS 0162	5			2*10Ω-12000W	IP20	B	5	16(6)

Type of connection:
A-One resistor
B-Two or multiple parallel-connected resistors
C-Two series-connected resistors

BRAKING RESISTORS FOR S05-S30 - 4T

Applications with DUTY CYCLE 50% - Class 4T

Inverter			Braking resistors						
Size	Sinus Penta model	Min. Applicable resistor (Ω)	Part number	Number of resistors	Type	Degree of protection	Type of connection	Value (Ω)	Wire cross section mm ² (AWG)
S05	SINUS 0005	50	RE3483500	1	50Ω-4000W	IP23	A	50	4(12)
	SINUS 0007	50			50Ω-4000W	IP23	A	50	4(12)
	SINUS 0009	50			50Ω-4000W	IP23	A	50	4(12)
	SINUS 0011	50			50Ω-4000W	IP23	A	50	4(12)
	SINUS 0014	50			50Ω-4000W	IP23	A	50	4(12)
S12	SINUS 0016	40	RE3783500	1	50Ω-8000W	IP23	A	50	4(12)
	SINUS 0017	40			50Ω-8000W	IP23	A	50	4(12)
	SINUS 0020	40			50Ω-8000W	IP23	A	50	4(12)
	SINUS 0025	20	RE4053200	1	20Ω-12000W	IP23	A	20	10(8)
	SINUS 0030	20			20Ω-12000W	IP23	A	20	10(8)
	SINUS 0034	20	RE4163200	1	20Ω-16000W	IP23	A	20	10(8)
SINUS 0036	20	20Ω-16000W			IP23	A	20	10(8)	
S15	SINUS 0040	15	RE4293150	1	15Ω-24000W	IP23	A	15	16(6)
	SINUS 0049	10			15Ω-24000W	IP23	A	15	16(6)
S20	SINUS 0060	10	RE4293100	1	10Ω-24000W	IP23	A	10	16(6)
	SINUS 0067	10			10Ω-24000W	IP23	A	10	16(6)
	SINUS 0074	7.5	RE4293150	2	2*15Ω-24000W	IP23	B	7.5	16(6)
	SINUS 0086	7.5			2*15Ω-24000W	IP23	B	7.5	16(6)
S30	SINUS 0113	6	RE4552600	1	6Ω-64000W	IP23	A	6	35(2)
	SINUS 0129	6			6Ω-64000W	IP23	A	6	35(2)
	SINUS 0150	5	RE4552500	1	5Ω-64000W	IP23	A	5	50(1/0)
	SINUS 0162	5			5Ω-64000W	IP23	A	5	50(1/0)

A-One resistor
B-Two or multiple parallel-connected resistors

BRAKING RESISTORS FOR S14-S32 - 5T

Applications with DUTY CYCLE 10% - Class 5T

Inverter			Braking resistors						
Size	Sinus Penta model	Min. Applicable resistor (Ω)	Part number	Number of resistors	Type	Degree of protection	Type of connection	Value (Ω)	Wire cross section mm ² (AWG)
S14	SINUS 0003	120	RE3084250	1	250Ω-1100W	IP55	A	250	10(8)
	SINUS 0004	120	RE3084180	1	180Ω-1100W	IP55	A	180	10(8)
	SINUS 0006	60	RE3104120	1	120Ω-1800W	IP55	A	120	10(8)
	SINUS 0012	60	RE3114100	1	100Ω-2200W	IP55	A	100	10(8)
	SINUS 0018	60	RE3483820	1	82Ω-4000W	IP20	A	82	10(8)
	SINUS 0019	40	RE3483600	1	60Ω-4000W	IP20	A	60	10(8)
	SINUS 0021	40	RE3483450	1	45Ω-4000W	IP23	A	45	10(8)
	SINUS 0022	25			45Ω-4000W	IP23	A	45	10(8)
	SINUS 0024	25	RE3483300	1	30Ω-4000W	IP23	A	30	10(8)
	SINUS 0032	20			22Ω-8000W	IP23	A	22	10(8)
S22	SINUS 0042	12	RE3783220	1	22Ω-8000W	IP23	A	22	10(8)
	SINUS 0051	12			18Ω-8000W	IP23	A	18	10(8)
	SINUS 0062	12	RE4053150	1	15Ω-12000W	IP23	A	15	10(8)
	SINUS 0069	12	RE4053120	1	12Ω-12000W	IP23	A	12	10(8)
S32	SINUS 0076	8	RE4053100	1	10Ω-12000W	IP23	A	10	16(6)
	SINUS 0088	8	RE4162820	1	8.2Ω-16000W	IP23	A	8.2	16(6)
	SINUS 0131	5	RE4292660	1	6.6Ω-24000W	IP23	A	6.6	16(6)
	SINUS 0164	5	RE4292500	1	5Ω-24000W	IP23	A	5	16(6)

Type of connection:
A-One resistor

Applications with DUTY CYCLE 20% - Class 5T

Inverter			Braking resistors						
Size	Sinus Penta model	Min. Applicable resistor (Ω)	Part number	Number of resistors	Type	Degree of protection	Type of connection	Value (Ω)	Wire cross section mm ² (AWG)
S14	SINUS 0003	120	RE3094250	1	250Ω-1500W	IP55	A	250	10(8)
	SINUS 0004	120	RE3094180	1	180Ω-1500W	IP55	A	180	10(8)
	SINUS 0006	60	RE3484120	1	120Ω-4000W	IP20	A	120	10(8)
	SINUS 0012	60	RE3484100	1	100Ω-4000W	IP20	A	100	10(8)
	SINUS 0018	60	RE3483820	1	82Ω-4000W	IP23	A	82	10(8)
	SINUS 0019	40	RE3483600	1	60Ω-4000W	IP23	A	60	10(8)
	SINUS 0021	40	RE3783450	1	45Ω-8000W	IP20	A	45	10(8)
	SINUS 0022	25			45Ω-8000W	IP23	A	45	10(8)
	SINUS 0024	25	RE3783300	1	30Ω-8000W	IP23	A	30	10(8)
	SINUS 0032	20	RE4053220	1	22Ω-12000W	IP23	A	22	10(8)
S22	SINUS 0042	12			22Ω-12000W	IP23	A	22	10(8)
	SINUS 0051	12	RE4053180	1	18Ω-12000W	IP23	A	18	10(8)
	SINUS 0062	12	RE4163150	1	15Ω-16000W	IP23	A	15	10(8)
S32	SINUS 0069	12	RE4163120	1	12Ω-16000W	IP23	A	12	10(8)
	SINUS 0076	8	RE4293100	1	10Ω-24000W	IP23	A	10	16(6)
	SINUS 0088	8	RE4292820	1	8.2Ω-24000W	IP23	A	8.2	16(6)
	SINUS 0131	5	RE4362660	1	6.6Ω-32000W	IP23	A	6.6	25(3)
SINUS 0164	5	RE4452500	1	5Ω-48000W	IP23	A	5	25(3)	

Type of connection:
A-One resistor
B-Two or multiple parallel-connected resistors

BRAKING RESISTORS FOR S14-S32 - 5T

Applications with DUTY CYCLE 50% - Class 5T

Inverter			Braking resistors						
Size	Sinus Penta model	Min. Applicable resistor (Ω)	Part number	Number of resistors	Type	Degree of protection	Type of connection	Value (Ω)	Wire cross section mm ² (AWG)
S14	SINUS 0003	120	RE3114250	1	250Ω-2200W	IP55	A	250	16(6)
	SINUS 0004	120	RE3484180	1	180Ω-4000W	IP20	A	180	16(6)
	SINUS 0006	60	RE3484120	1	120Ω-4000W	IP23	A	120	16(6)
	SINUS 0012	60	RE3484100	1	100Ω-4000W	IP23	A	100	16(6)
	SINUS 0018	60	RE3783820	1	82Ω-8000W	IP20	A	82	16(6)
	SINUS 0019	40	RE3783600	1	60Ω-8000W	IP23	A	60	16(6)
	SINUS 0021	40	RE4053450	1	45Ω-12000W	IP20	A	45	16(6)
	SINUS 0022	25			45Ω-12000W	IP23	A	45	16(6)
	SINUS 0024	25	RE4163300	1	30Ω-16000W	IP23	A	30	16(6)
	SINUS 0032	20	RE4163220	1	22Ω-16000W	IP23	A	22	16(6)
S22	SINUS 0042	12	RE4293220	1	22Ω-24000W	IP23	A	22	16(6)
	SINUS 0051	12	RE4293180	1	18Ω-24000W	IP23	A	18	16(6)
	SINUS 0062	12	RE4363150	1	15Ω-32000W	IP23	A	15	16(6)
	SINUS 0069	12	RE4453120	1	12Ω-48000W	IP23	A	12	16(6)
S32	SINUS 0076	8	RE4453100	1	10Ω-48000W	IP23	A	10	25(3)
	SINUS 0088	8	RE4552820	1	8.2Ω-64000W	IP23	A	8.2	25(3)
	SINUS 0131	5	RE4552660	1	6.6Ω-64000W	IP23	A	6.6	50(1/0)
	SINUS 0164	5	RE4453100	2	2x10Ω-48000W	IP23	B	5	50(1/0)

Type of connection:
A-One resistor
B-Two or multiple parallel-connected resistors

BRAKING RESISTORS FOR S14-S32 - 6T

Applications with DUTY CYCLE 10% - Class 6T

Inverter			Braking resistors						
Size	Sinus Penta model	Min. Applicable resistor (Ω)	Part number	Number of resistors	Type	Degree of protection	Type of connection	Value	Wire cross section
								(Ω)	mm ² (AWG)
S14	SINUS 0003	150	RE3094250	1	250Ω-1500W	IP55	A	250	10(8)
	SINUS 0004	150	RE3114180	1	180Ω-2200W	IP55	A	180	10(8)
	SINUS 0006	80	RE3114150	1	150Ω-2200W	IP55	A	150	10(8)
	SINUS 0012	80	RE3484120	1	120Ω-4000W	IP20	A	120	10(8)
	SINUS 0018	80	RE3483820	1	82Ω-4000W	IP20	A	82	10(8)
	SINUS 0019	50	RE3483600	1	60Ω-4000W	IP23	A	60	10(8)
	SINUS 0021	50			60Ω-4000W	IP23	A	60	10(8)
	SINUS 0022	30	RE3483450	1	45Ω-4000W	IP23	A	45	10(8)
	SINUS 0024	30	RE3783300	1	30Ω-8000W	IP23	A	30	10(8)
	SINUS 0032	25			30Ω-8000W	IP23	A	30	10(8)
S22	SINUS 0042	15	RE3783220	1	22Ω-8000W	IP23	A	22	10(8)
	SINUS 0051	15	RE4053180	1	18Ω-12000W	IP23	A	18	10(8)
	SINUS 0062	15	RE4053150	1	15Ω-12000W	IP23	A	15	10(8)
	SINUS 0069	15			15Ω-12000W	IP23	A	15	10(8)
S32	SINUS 0076	10	RE4163100	1	10Ω-16000W	IP23	A	10	16(6)
	SINUS 0088	10	RE4293100	1	10Ω-24000W	IP23	A	10	16(6)
	SINUS 0131	6	RE4292660	1	6.6Ω-24000W	IP23	A	6.6	16(6)
	SINUS 0164	6	RE4362600	1	6Ω-32000W	IP23	A	6	16(6)

Type of connection:
A-One resistor

Applications with DUTY CYCLE 20% - Class 6T

Inverter			Braking resistors						
Size	Sinus Penta model	Min. Applicable resistor (Ω)	Part number	Number of resistors	Type	Degree of protection	Type of connection	Value	Wire cross section
								(Ω)	mm ² (AWG)
S14	SINUS 0003	150	RE3114250	1	250Ω-2200W	IP55	A	250	10(8)
	SINUS 0004	150	RE3484180	1	180Ω-4000W	IP20	A	180	10(8)
	SINUS 0006	80	RE3484150	1	150Ω-4000W	IP20	A	150	10(8)
	SINUS 0012	80	RE3484120	1	120Ω-4000W	IP23	A	120	10(8)
	SINUS 0018	80	RE3483820	1	82Ω-4000W	IP23	A	82	10(8)
	SINUS 0019	50	RE3483600	1	60Ω-4000W	IP23	A	60	10(8)
	SINUS 0021	50	RE3783600	1	60Ω-8000W	IP23	A	60	10(8)
	SINUS 0022	30	RE3783450	1	45Ω-8000W	IP23	A	45	10(8)
	SINUS 0024	30	RE3783300	1	30Ω-8000W	IP23	A	30	10(8)
	SINUS 0032	25	RE4053300	1	30Ω-12000W	IP23	A	30	10(8)
S22	SINUS 0042	15	RE4053220	1	22Ω-12000W	IP23	A	22	10(8)
	SINUS 0051	15	RE4163180	1	18Ω-16000W	IP23	A	18	10(8)
	SINUS 0062	15	RE4163150	1	15Ω-16000W	IP23	A	15	10(8)
SINUS 0069	15	15Ω-16000W			IP23	A	15	10(8)	
S32	SINUS 0076	10	RE4293100	1	10Ω-24000W	IP23	A	10	16(6)
	SINUS 0088	10	RE4363100	1	10Ω-32000W	IP23	A	10	16(6)
	SINUS 0131	6	RE4452660	1	6.6Ω-48000W	IP23	A	6.6	25(3)
	SINUS 0164	6	RE4452600	1	6Ω-48000W	IP23	A	6	25(3)

Type of connection:
A-One resistor

BRAKING RESISTORS FOR S14-S32 - 6T

Applications with DUTY CYCLE 50% - Class 6T

Inverter			Braking resistors							
Size	Sinus Penta model	Min. Applicable resistor (Ω)	Part number	Number of resistors	Type	Degree of protection	Type of connection	Value	Wire cross section	
								(Ω)	mm ² (AWG)	
S14	SINUS 0003	150	RE3484250	1	250Ω-4000W	IP20	A	250	16(6)	
	SINUS 0004	150	RE3484180	1	180Ω-4000W	IP23	A	180	16(6)	
	SINUS 0006	80	RE3484150	1	150Ω-4000W	IP23	A	150	16(6)	
	SINUS 0012	80	RE3784120	1	120Ω-8000W	IP20	A	120	16(6)	
	SINUS 0018	80	RE3783820	1	82Ω-8000W	IP23	A	82	16(6)	
	SINUS 0019	50	RE3783600	1	60Ω-8000W	IP23	A	60	16(6)	
	SINUS 0021	50	RE4053600	1	60Ω-12000W	IP23	A	60	16(6)	
	SINUS 0022	30	RE4163450	1	45Ω-16000W	IP23	A	45	16(6)	
	SINUS 0024	30	RE4163430	1	30Ω-16000W	IP23	A	30	16(6)	
	SINUS 0032	25	RE4293300	1	30Ω-24000W	IP23	A	30	16(6)	
	S22	SINUS 0042	15	RE4293220	1	22Ω-24000W	IP23	A	22	16(6)
		SINUS 0051	15	RE4362660	1	18Ω-32000W	IP23	A	18	16(6)
		SINUS 0062	15	RE4453150	1	15Ω-48000W	IP23	A	15	16(6)
SINUS 0069		15	15Ω-48000W			IP23	A	15	16(6)	
S32	SINUS 0076	10	RE4553100	1	10Ω-64000W	IP23	A	10	25(3)	
	SINUS 0088	10			10Ω-64000W	IP23	A	10	25(3)	
	SINUS 0131	6	RE4452300	2	2x3Ω-48000W	IP23	C	6	50(1/0)	
	SINUS 0164	6			2x3Ω-48000W	IP23	C	6	50(1/0)	

Type of connection:
A-One resistor
C-Two series-connected resistors

BRAKING UNIT AND RESISTORS FOR BU200

BRAKING UNIT AND RESISTORS FOR BU200

BU200 Ratings

Size	Max. Braking Current (A)	Average Braking Current (A)	Inverter Supply Voltage		
			200-240Vac (class 2T)	380-480Vac (class 4T)	481-500Vac (class 4T)
			Min. Braking Resistor (Ω)		
BU200	130	80	3	6	6

Braking resistors for BU200 - 2T

Applications with DUTY CYCLE 10% - Class 2T

Size	Sinus Penta Model	Braking Unit		Braking Resistors					
		Q.ty	Q.ty	Resistors to be used			Type of connection	Value (Ω)	Wire Cross-section mm ² (AWG or kcmils)
				Recommended Value (Ω)	Power (kW)	Degree of Protection			
S41	SINUS 0180	2	2	3.3	8	IP20	M	3.3/2	10(8)
	SINUS 0202	2	2	3.3	8	IP20	M	3.3/2	10(8)
	SINUS 0217	3	3	3.3	8	IP20	N	3.3/3	10(8)
	SINUS 0260	3	3	3.3	8	IP20	N	3.3/3	10(8)
S51	SINUS 0313	4	4	3.3	8	IP20	O	3.3/4	10(8)
	SINUS 0367	5	5	3.3	8	IP20	P	3.3/5	10(8)
	SINUS 0402	5	5	3.3	8	IP20	P	3.3/5	10(8)
S60	SINUS 0457	6	6	3.3	8	IP20	Q	3.3/6	10(8)
	SINUS 0524	6	6	3.3	8	IP20	Q	3.3/6	W(8)

Applications with DUTY CYCLE 20% - Class 2T

Size	Sinus Penta Model	Braking Unit		Braking Resistors					
		Q.ty	Q.ty	Resistors to be used			Type of connection	Value (Ω)	Wire Cross-section mm ² (AWG or kcmils)
				Recommended Value (Ω)	Power (kW)	Degree of Protection			
S41	SINUS 0180	2	2	3.3	8	IP20	M	3.3/2	16(6)
	SINUS 0202	2	2	3.3	8	IP20	M	3.3/2	16(6)
	SINUS 0217	3	3	3.3	12	IP20	N	3.3/3	16(6)
	SINUS 0260	3	3	3.3	12	IP20	N	3.3/3	16(6)
S51	SINUS 0313	4	4	3.3	12	IP20	O	3.3/4	16(6)
	SINUS 0367	5	5	3.3	12	IP20	P	3.3/5	16(6)
	SINUS 0402	5	5	3.3	12	IP20	P	3.3/5	16(6)
S60	SINUS 0457	6	6	3.3	12	IP20	Q	3.3/6	16(6)
	SINUS 0524	6	6	3.3	12	IP20	Q	3.3/6	16(6)

Applications with DUTY CYCLE 50% - Class 2T

Size	Sinus Penta Model	Braking Unit		Braking Resistors					
		Q.ty	Q.ty	Resistors to be used			Type of connection	Value (Ω)	Wire Cross-section mm ² (AWG or kcmils)
				Recommended Value (Ω)	Power (kW)	Degree of Protection			
S41	SINUS 0180	2	4	6.6	12	IP20	V	3.3/2	16(6)
	SINUS 0202	2	4	6.6	12	IP20	V	3.3/2	16(6)
	SINUS 0217	3	6	6.6	12	IP20	N	3.3/3	16(6)
	SINUS 0260	3	6	6.6	12	IP20	N	3.3/3	16(6)
S51	SINUS 0313	4	8	6.6	12	IP20	Y	3.3/4	16(6)
	SINUS 0367	5	10	6.6	12	IP20	Y	3.3/5	16(6)
	SINUS 0402	5	10	6.6	12	IP20	W	3.3/5	16(6)
S60	SINUS 0457	6	12	6.6	12	IP20	Z	3.3/6	16(6)
	SINUS 0524	6	12	6.6	12	IP20	Z	3.3/6	16(6)

Braking resistors for BU200 - 4T

Applications with DUTY CYCLE 10% - Class 4T

Size	Sinus Penta Model	Braking Unit		Braking Resistors					
		Q.ty	Q.ty	Resistors to be used			Type of connection	Value (Ω)	Wire Cross-section mm ² (AWG or kcmils)
				Recommended Value (Ω)	Power (kW)	Degree of Protection			
S41	SINUS 0180	2	2	6.6	12	IP20	M	6.6/2	16(6)
	SINUS 0202	2	2	6.6	12	IP20	M	6.6/2	16(6)
	SINUS 0217	3	3	6.6	12	IP20	N	6.6/3	16(6)
	SINUS 0260	3	3	6.6	12	IP20	N	6.6/3	16(6)
S51	SINUS 0313	3	3	6.6	12	IP20	N	6.6/3	16(6)
	SINUS 0367	4	4	6.6	12	IP20	O	6.6/4	16(6)
	SINUS 0402	4	4	6.6	12	IP20	O	6.6/4	16(6)
S60	SINUS 0457	4	4	6.6	12	IP20	O	6.6/4	16(6)
	SINUS 0524	5	5	6.6	12	IP20	P	6.6/5	16(6)
S60P	SINUS 0598P	6	6	6.6	12	IP20	Q	6.6/6	16(6)

Applications with DUTY CYCLE 20% - Class 4T

Size	Sinus Penta Model	Braking Unit		Braking Resistors					
		Q.ty	Q.ty	Resistors to be used			Type of connection	Value (Ω)	Wire Cross-section mm ² (AWG or kcmils)
				Recommended Value (Ω)	Power (kW)	Degree of Protection			
S41	SINUS 0180	2	2	6.6	24	IP23	M	6.6/2	16(6)
	SINUS 0202	2	2	6.6	24	IP23	M	6.6/2	16(6)
	SINUS 0217	3	3	6.6	24	IP23	N	6.6/3	16(6)
	SINUS 0260	3	3	6.6	24	IP23	N	6.6/3	16(6)
S51	SINUS 0313	3	3	6.6	24	IP23	N	6.6/3	16(6)
	SINUS 0367	4	4	6.6	24	IP23	O	6.6/4	16(6)
	SINUS 0402	4	4	6.6	24	IP23	O	6.6/4	16(6)
S60	SINUS 0457	4	4	6.6	24	IP23	O	6.6/4	16(6)
	SINUS 0524	5	5	6.6	24	IP23	P	6.6/5	16(6)
S60P	SINUS 0598P	6	6	6.6	24	IP23	Q	6.6/6	16(6)

Applications with DUTY CYCLE 50% - Class 4T

Size	Sinus Penta Model	Braking Unit		Braking Resistors					
		Q.ty	Q.ty	Resistors to be used			Type of connection	Value (Ω)	Wire Cross-section mm ² (AWG or kcmils)
				Recommended Value (Ω)	Power (kW)	Degree of Protection			
S41	SINUS 0180	3	3	10	24	IP23	N	10/3	16(6)
	SINUS 0202	3	3	10	24	IP23	N	10/3	16(6)
	SINUS 0217	4	4	10	24	IP23	O	10/4	16(6)
	SINUS 0260	5	4	10	24	IP23	O	10/4	16(6)
S51	SINUS 0313	5	5	10	24	IP23	P	10/5	16(6)
	SINUS 0367	6	6	10	24	IP23	Q	10/6	16(6)
	SINUS 0402	7	7	10	24	IP23	R	10/7	16(6)
S60	SINUS 0457	7	7	10	24	IP23	R	10/7	16(6)
	SINUS 0524	8	8	10	24	IP23	S	10/8	16(6)
S60P	SINUS 0598P	8	8	10	24	IP23	S	10/8	16(6)

BRAKING UNIT AND RESISTORS FOR BU700

BU700 Ratings

Model	Max. Braking Current (A)	Average Braking Current (A)	Penta Supply Voltage	Min. Braking Resistor (Ω)	Power Dissipated (at Average Braking Current) (W)
BU700 2T-4T	700	350	200-240Vac	0.54	700
BU700 2T-4T	700	350	380-500Vac	1.1	700

Braking resistors for BU700 - 2T

Applications with DUTY CYCLE 10% - Class 2T

Size	Sinus Penta Model	Braking Unit		Resistors to be used				Type of connection	Value (Ω)	Wire Cross-section mm ² (AWG or kcmils)
		Q.ty	Q.ty	Recommended Value (Ω)	Power (kW)	Degree of Protection				
S41	SINUS 0180	1	2	3.3	8	IP20	B	1.65	16(6)	
	SINUS 0202	1	2	3.3	8	IP20	B	1.65	16(6)	
	SINUS 0217	1	3	3.3	8	IP20	B	1.1	16(6)	
	SINUS 0260	1	3	3.3	8	IP20	B	1.1	16(6)	
S51	SINUS 0313	1	4	3.3	8	IP20	B	0.825	16(6)	
	SINUS 0367	1	4	3.3	8	IP20	B	0.825	16(6)	
	SINUS 0402	1	1	0.6	48	IP23	A	0.6	95(4/0)	

Applications with DUTY CYCLE 20% - Class 2T

Size	Sinus Penta Model	Braking Unit		Resistors to be used				Type of connection	Value (Ω)	Wire Cross-section mm ² (AWG or kcmils)
		Q.ty	Q.ty	Recommended Value (Ω)	Power (kW)	Degree of Protection				
S41	SINUS 0180	1	2	3.3	12	IP20	B	1.65	16(6)	
	SINUS 0202	1	2	3.3	12	IP20	B	1.65	16(6)	
	SINUS 0217	1	3	3.3	12	IP20	B	1.1	16(6)	
	SINUS 0260	1	3	3.3	12	IP20	B	1.1	16(6)	
S51	SINUS 0313	1	4	3.3	12	IP20	B	0.825	16(6)	
	SINUS 0367	1	4	3.3	12	IP20	B	0.825	16(6)	
	SINUS 0402	1	1	0.6	64	IP23	A	0.6	185(350)	

Applications with DUTY CYCLE 50% - Class 2T

Size	Sinus Penta Model	Braking Unit		Resistors to be used				Type of connection	Value (Ω)	Wire Cross-section mm ² (AWG or kcmils)
		Q.ty	Q.ty	Recommended Value (Ω)	Power (kW)	Degree of Protection				
S41	SINUS 0180	1	4	6.6	12	IP20	B	1.65	16(4)	
	SINUS 0202	1	4	6.6	12	IP20	B	1.65	16(4)	
	SINUS 0217	1	1	1.2	64	IP23	A	1.2	120(250)	
	SINUS 0260	1	1	1.2	64	IP23	A	1.2	120(250)	
S51	SINUS 0313	1	2	1.6	48	IP23	B	0.8	95(4/0)	
	SINUS 0367	1	2	1.6	48	IP23	B	0.8	95(4/0)	
	SINUS 0402	1	2	1.2	64	IP23	B	0.6	120(250)	

BRAKING UNIT AND RESISTORS FOR BU700

Braking resistors for BU700 - 4T

Applications with DUTY CYCLE 10% - Class 4T

Size	Sinus Penta Model	Braking Unit		Resistors to be used				Type of connection	Value (Ω)	Wire Cross-section mm ² (AWG or kcmils)
		Q.ty	Q.ty	Recommended Value (Ω)	Power (kW)	Degree of Protection				
S41	SINUS 0180	1	1	3.6	16	IP23	A	3.6	25(3)	
	SINUS 0202	1	1	3	24	IP23	A	3.0	25(3)	
	SINUS 0217	1	1	2.8	32	IP23	A	2.8	35(2)	
	SINUS 0260	1	1	2.4	32	IP23	A	2.4	35(2)	
S51	SINUS 0313	1	1	1.8	32	IP23	A	1.8	50(1/0)	
	SINUS 0367	1	1	1.8	32	IP23	A	1.8	50(1/0)	
	SINUS 0402	1	1	1.4	48	IP23	A	1.4	70(2/0)	

Applications with DUTY CYCLE 20% - Class 4T

Size	Sinus Penta Model	Braking Unit		Resistors to be used				Type of connection	Value (Ω)	Wire Cross-section mm ² (AWG or kcmils)
		Q.ty	Q.ty	Recommended Value (Ω)	Power (kW)	Degree of Protection				
S41	SINUS 0180	1	1	3.6	32	IP23	A	3.6	50(1/0)	
	SINUS 0202	1	1	3	48	IP23	A	3.0	50(1/0)	
	SINUS 0217	1	1	2.8	48	IP23	A	2.8	70(2/0)	
	SINUS 0260	1	1	2.4	48	IP23	A	2.4	70(2/0)	
S51	SINUS 0313	1	1	1.8	64	IP23	A	1.8	95(4/0)	
	SINUS 0367	1	1	1.8	64	IP23	A	1.8	95(4/0)	
	SINUS 0402	1	2	2.8	48	IP23	B	1.4	70(2/0)	

Applications with DUTY CYCLE 50% - Class 4T

Size	Sinus Penta Model	Braking Unit		Resistors to be used				Type of connection	Value (Ω)	Wire Cross-section mm ² (AWG or kcmils)
		Q.ty	Q.ty	Recommended Value (Ω)	Power (kW)	Degree of Protection				
S41	SINUS 0180	1	2	6.6	48	IP23	B	3.3	35(2)	
	SINUS 0202	1	2	6.0	64	IP23	B	3.0	35(2)	
	SINUS 0217	1	2	5.0	64	IP23	B	2.5	50(1/0)	
	SINUS 0260	1	2	5.0	64	IP23	B	2.5	50(1/0)	
S51	SINUS 0313	1	4	1.6	48	IP23	D	1.6	95(4/0)	
	SINUS 0367	1	4	1.6	48	IP23	D	1.6	95(4/0)	
	SINUS 0402	1	4	1.4	64	IP23	D	1.4	95(4/0)	

BRAKING UNIT AND RESISTORS FOR BU600

BRAKING UNIT AND RESISTORS FOR BU600

BU600 Ratings

Model	Max. Braking Current (A)	Average Braking Current (A)	Penta Supply Voltage	Min. Braking Resistor (Ω)	Power Dissipated (at Average Braking Current) (W)
BU600 5T-6T	600	300	500-600Vac	1.6	700
BU600 5T-6T	600	300	575-690Vac	1.8	700

Braking resistors for BU600 - 5T

Applications with DUTY CYCLE 10% - Class 5T

Size	Sinus Penta Model	Braking Unit		Resistors to be used				Type of connection	Value (Ω)	Wire Cross-section mm ² (AWG or kcmils)
		Q.ty	Q.ty	Recommended Value (Ω)	Power (kW)	Degree of Protection				
S42	SINUS 0181	1	1	4.2	32	IP23	A	4.2	25(3)	
	SINUS 0201	1	1	3.6	32	IP23	A	3.6	35(2)	
	SINUS 0218	1	1	3.6	32	IP23	A	3.6	35(2)	
	SINUS 0259	1	1	3.0	32	IP23	A	3.0	35(2)	
S52	SINUS 0290	1	1	3.0	32	IP23	A	3.0	70(2/0)	
	SINUS 0314	1	1	2.4	48	IP23	A	2.4	70(2/0)	
	SINUS 0368	1	1	2.4	48	IP23	A	2.4	70(2/0)	
	SINUS 0401	1	1	1.8	64	IP23	A	1.8	95(4/0)	

Applications with DUTY CYCLE 20% - Class 5T

Size	Sinus Penta Model	Braking Unit		Resistors to be used				Type of connection	Value (Ω)	Wire Cross-section mm ² (AWG or kcmils)
		Q.ty	Q.ty	Recommended Value (Ω)	Power (kW)	Degree of Protection				
S42	SINUS 0181	1	1	4.2	48	IP23	A	4.2	50(1/0)	
	SINUS 0201	1	1	3.6	64	IP23	A	3.6	50(1/0)	
	SINUS 0218	1	2	6.0	32	IP23	B	3.0	25(3)	
	SINUS 0259	1	2	6.0	32	IP23	B	3.0	25(3)	
S52	SINUS 0290	1	2	6.0	32	IP23	B	3.0	25(3)	
	SINUS 0314	1	2	5.0	48	IP23	B	2.5	35(2)	
	SINUS 0368	1	2	5.0	48	IP23	B	2.5	35(2)	
	SINUS 0401	1	2	3.6	64	IP23	B	1.8	50(1/0)	

Applications with DUTY CYCLE 50% - Class 5T

Size	Sinus Penta Model	Braking Unit		Resistors to be used				Type of connection	Value (Ω)	Wire Cross-section mm ² (AWG or kcmils)
		Q.ty	Q.ty	Recommended Value (Ω)	Power (kW)	Degree of Protection				
S42	SINUS 0181	1	4	4.2	32	IP23	D	4.2	35(2)	
	SINUS 0201	1	4	3.6	48	IP23	D	3.6	50(1/0)	
	SINUS 0218	1	4	3.6	48	IP23	D	3.6	50(1/0)	
	SINUS 0259	1	4	3.0	48	IP23	D	3.0	70(2/0)	
S52	SINUS 0290	1	4	2.4	48	IP23	D	2.4	70(2/0)	
	SINUS 0314	1	4	2.4	48	IP23	D	2.4	70(2/0)	
	SINUS 0368	1	4	2.4	64	IP23	D	2.4	70(2/0)	
	SINUS 0401	1	4	1.8	64	IP23	D	1.8	95(4/0)	

Braking resistors for BU600 - 6T

Applications with DUTY CYCLE 10% - Class 6T

Size	Sinus Penta Model	Braking Unit		Resistors to be used				Type of connection	Value (Ω)	Wire Cross-section mm ² (AWG or kcmils)
		Q.ty	Q.ty	Recommended Value (Ω)	Power (kW)	Degree of Protection				
S42	SINUS 0181	1	1	5.0	32	IP23	A	5.0	25(3)	
	SINUS 0201	1	1	3.6	32	IP23	A	3.6	35(2)	
	SINUS 0218	1	1	3.6	32	IP23	A	3.6	35(2)	
	SINUS 0259	1	1	3.6	48	IP23	A	3.6	70(2/0)	
S52	SINUS 0290	1	1	3.0	48	IP23	A	3.0	70(2/0)	
	SINUS 0314	1	1	2.4	48	IP23	A	2.4	70(2/0)	
	SINUS 0368	1	1	2.4	64	IP23	A	2.4	95(4/0)	
	SINUS 0401	1	1	1.8	64	IP23	A	1.8	120(250)	

Applications with DUTY CYCLE 20% - Class 6T

Size	Sinus Penta Model	Braking Unit		Resistors to be used				Type of connection	Value (Ω)	Wire Cross-section mm ² (AWG or kcmils)
		Q.ty	Q.ty	Recommended Value (Ω)	Power (kW)	Degree of Protection				
S42	SINUS 0181	1	1	5.0	48	IP23	A	4.2	50(1/0)	
	SINUS 0201	1	1	3.6	64	IP23	A	3.6	50(1/0)	
	SINUS 0218	1	1	3.6	64	IP23	A	3.6	50(1/0)	
	SINUS 0259	1	2	6.6	48	IP23	B	3.3	25(3)	
S52	SINUS 0290	1	2	6.0	48	IP23	B	3.0	35(2)	
	SINUS 0314	1	2	5.0	48	IP23	B	2.5	35(2)	
	SINUS 0368	1	2	5.0	64	IP23	B	2.5	50(1/0)	
	SINUS 0401	1	2	3.6	64	IP23	B	1.8	70(2/0)	

Applications with DUTY CYCLE 50% - Class 6T

Size	Sinus Penta Model	Braking Unit		Resistors to be used				Type of connection	Value (Ω)	Wire Cross-section mm ² (AWG or kcmils)
		Q.ty	Q.ty	Recommended Value (Ω)	Power (kW)	Degree of Protection				
S42	SINUS 0181	1	4	5.0	32	IP23	D	5.0	25(3)	
	SINUS 0201	1	4	3.6	48	IP23	D	3.6	70(2/0)	
	SINUS 0218	1	4	3.6	48	IP23	D	3.6	70(2/0)	
	SINUS 0259	1	4	3.6	48	IP23	D	3.6	70(2/0)	
S52	SINUS 0290	1	4	2.8	64	IP23	D	2.8	70(2/0)	
	SINUS 0314	1	4	2.4	64	IP23	D	2.4	70(2/0)	
	SINUS 0368	1	4	2.4	64	IP23	D	2.4	120(250)	
	SINUS 0401	1	4	1.8	64	IP23	D	1.8	120(250)	

BRAKING UNIT AND RESISTORS FOR BU1440

BRAKING UNIT AND RESISTORS FOR BU1440

BU1440 Ratings

Model	Max. Braking Current (A)	Average Braking Current (A)	Inverter Supply Voltage	Min. Braking Resistor (Ω)	Power Dissipated (at Average Braking Current) (W)
BU1440-4T	1600	800	380-500Vac	0.48	1800
BU1440-5T	1600	800	500-600Vac	0.58	2100
BU1440-6T	1600	800	575-690Vac	0.69	2200

Braking resistors for BU1440

Applications with DUTY CYCLE 10% - Class 4T

Size	Sinus Penta Model	Braking Unit		Resistors to be used				Type of connection	Value (Ω)	Wire Cross-section mm ² (AWG or kcmils)
		Q.ty	Q.ty	Recommended Value (Ω)	Power (kW)	Degree of Protection				
S65	SINUS 0598	1	1	1.2	64	IP23	A	1.2	95(4/0)	
	SINUS 0748	1	1	1.2	64	IP23	A	1.2	95(4/0)	
	SINUS 0831	1	2	1.6	48	IP23	B	0.8	120(250)	
S75	SINUS 0964	1	2	1.2	48	IP23	B	0.6	120(250)	
	SINUS 1130	1	2	1.2	64	IP23	B	0.6	120(250)	
	SINUS 1296	2	4	1.8	32	IP23	V	0.45	95(4/0)	
S90	SINUS 1800	2	4	1.6	48	IP23	V	0.4	120(250)	
	SINUS 2076	2	4	1.2	48	IP23	V	0.3	120(250)	

Applications with DUTY CYCLE 20% - Class 4T

Size	Sinus Penta Model	Braking Unit		Resistors to be used				Type of connection	Value (Ω)	Wire Cross-section mm ² (AWG or kcmils)
		Q.ty	Q.ty	Recommended Value (Ω)	Power (kW)	Degree of Protection				
S65	SINUS 0598	1	2	2.4	64	IP23	B	1.2	120(250)	
	SINUS 0748	1	2	2.4	64	IP23	B	1.2	120(250)	
	SINUS 0831	1	3	2.4	48	IP23	B	0.8	120(250)	
S75	SINUS 0964	1	4	2.4	64	IP23	B	0.6	120(250)	
	SINUS 1130	1	4	2.4	64	IP23	B	0.6	120(250)	
	SINUS 1296	2	4	1.8	64	IP23	V	0.45	120(250)	
S90	SINUS 1800	2	6	2.4	48	IP23	V	0.4	120(250)	
	SINUS 2076	2	8	2.4	64	IP23	V	0.3	120(250)	

Applications with DUTY CYCLE 50% - Class 4T

Size	Sinus Penta Model	Braking Unit		Resistors to be used				Type of connection	Value (Ω)	Wire Cross-section mm ² (AWG or kcmils)
		Q.ty	Q.ty	Recommended Value (Ω)	Power (kW)	Degree of Protection				
S65	SINUS 0598	1	4	1.2	64	IP23	D	1.2	120(250)	
	SINUS 0748	1	4	1.2	64	IP23	D	1.2	120(250)	
	SINUS 0831	1	6	1.2	64	IP23	E	0.8	120(250)	
S75	SINUS 0964	1	8	1.2	64	IP23	F	0.6	120(250)	
	SINUS 1130	1	8	1.2	64	IP23	F	0.6	120(250)	
	SINUS 1296	2	12	1.4	64	IP23	ME	0.47	120(250)	
S90	SINUS 1800	2	12	1.2	64	IP23	ME	0.4	120(250)	
	SINUS 2076	2	16	1.2	64	IP23	MF	0.3	120(250)	

Braking resistors for BU1440 - 5T

Applications with DUTY CYCLE 10% - Class 5T

Size	Sinus Penta Model	Braking Unit		Resistors to be used				Type of connection	Value (Ω)	Wire Cross-section mm ² (AWG or kcmils)
		Q.ty	Q.ty	Recommended Value (Ω)	Power (kW)	Degree of Protection				
S65	SINUS 0457	1	1	1.6	64	IP23	A	1.6	95(1/0)	
	SINUS 0524	1	2	2.8	48	IP23	B	1.4	50(1/0)	
	SINUS 0598	1	2	2.4	48	IP23	B	1.2	50(1/0)	
	SINUS 0748	1	2	2.1	48	IP23	B	1.05	95(4/0)	
S70	SINUS 0831	1	2	1.8	64	IP23	B	0.9	95(4/0)	
S75	SINUS 0964	1	3	2.4	48	IP23	B	0.8	50(1/0)	
	SINUS 1130	1	3	1.8	64	IP23	B	0.6	95(4/0)	
S80	SINUS 1296	1	3	1.6	64	IP23	B	0.53	95(4/0)	
S90	SINUS 1800	2	4	1.8	64	IP23	V	0.45	95(4/0)	
	SINUS 2076	2	6	2.4	48	IP23	V	0.4	50(1/0)	

Applications with DUTY CYCLE 20% - Class 5T

Size	Sinus Penta Model	Braking Unit		Resistors to be used				Type of connection	Value (Ω)	Wire Cross-section mm ² (AWG or kcmils)
		Q.ty	Q.ty	Recommended Value (Ω)	Power (kW)	Degree of Protection				
S65	SINUS 0457	1	2	3.6	64	IP23	B	1.8	95(4/0)	
	SINUS 0524	1	3	4.2	64	IP23	B	1.4	50(1/0)	
	SINUS 0598	1	3	3.6	64	IP23	B	1.2	50(1/0)	
	SINUS 0748	1	3	2.8	64	IP23	B	0.93	70(2/0)	
S70	SINUS 0831	1	3	2.4	64	IP23	B	0.8	95(4/0)	
S75	SINUS 0964	1	4	2.8	64	IP23	B	0.7	70(2/0)	
	SINUS 1130	1	6	3.6	64	IP23	B	0.6	50(1/0)	
S80	SINUS 1296	1	6	3.0	64	IP23	B	0.5	70(2/0)	
S90	SINUS 1800	2	6	2.4	64	IP23	V	0.4	95(4/0)	
	SINUS 2076	2	8	2.8	64	IP23	V	0.35	70(2/0)	

Applications with DUTY CYCLE 50% - Class 5T

Size	Sinus Penta Model	Braking Unit		Resistors to be used				Type of connection	Value (Ω)	Wire Cross-section mm ² (AWG or kcmils)
		Q.ty	Q.ty	Recommended Value (Ω)	Power (kW)	Degree of Protection				
S65	SINUS 0457	1	6	2.4	64	IP23	E	1.6	70(4/0)	
	SINUS 0524	1	6	2.1	64	IP23	E	1.4	95(4/0)	
	SINUS 0598	1	8	2.4	64	IP23	F	1.2	70(2/0)	
	SINUS 0748	1	8	1.8	64	IP23	F	0.9	95(4/0)	
S70	SINUS 0831	1	8	1.8	64	IP23	F	0.9	95(4/0)	
S75	SINUS 0964	1	10	1.8	64	IP23	G	0.7	95(4/0)	
	SINUS 1130	1	12	1.8	64	IP23	H	0.6	95(4/0)	
S80	SINUS 1296	1	14	1.8	64	IP23	I	0.51	95(4/0)	
S90	SINUS 1800	2	16	1.8	64	IP23	MF	0.45	95(4/0)	
	SINUS 2076	2	20	1.8	64	IP23	MG	0.35	95(4/0)	

BRAKING UNIT AND RESISTORS FOR BU1440

Braking resistors for BU1400 - 6T

Applications with DUTY CYCLE 10% - Class 6T

Size	Sinus Penta Model	Braking Unit		Braking Resistors					Wire Cross-section mm ² (AWG or kcmils)
		Q.ty	Q.ty	Recommended Value (Ω)	Power (kW)	Degree of Protection	Type of connection	Value (Ω)	
S65	SINUS 0457	1	2	3.6	48	IP23	B	1.8	70(2/0)
	SINUS 0524	1	2	2.8	48	IP23	B	1.4	70(2/0)
	SINUS 0598	1	2	2.8	48	IP23	B	1.4	70(2/0)
	SINUS 0748	1	2	2.4	48	IP23	B	1.2	70(2/0)
S70	SINUS 0831	1	2	1.8	64	IP23	B	0.9	120(250)
S75	SINUS 0964	1	3	2.4	64	IP23	B	0.8	70(2/0)
	SINUS 1130	2	4	2.4	64	IP23	V	0.6	70(2/0)
S80	SINUS 1296	2	4	2.1	64	IP23	V	0.52	95(4/0)
S90	SINUS 1800	2	4	1.8	64	IP23	V	0.45	120(250)
	SINUS 2076	2	6	2.4	64	IP23	V	0.4	70(2/0)

Applications with DUTY CYCLE 20% - Class 6T

Size	Sinus Penta Model	Braking Unit		Braking Resistors					Wire Cross-section mm ² (AWG or kcmils)
		Q.ty	Q.ty	Recommended Value (Ω)	Power (kW)	Degree of Protection	Type of connection	Value (Ω)	
S65	SINUS 0457	1	3	5.0	64	IP23	B	1.7	50(1/0)
	SINUS 0524	1	3	4.2	64	IP23	B	1.4	50(1/0)
	SINUS 0598	1	3	4.2	64	IP23	B	1.4	70(2/0)
	SINUS 0748	1	3	3.6	64	IP23	B	1.2	70(2/0)
S70	SINUS 0831	1	4	3.6	64	IP23	B	0.9	70(2/0)
S75	SINUS 0964	1	6	1.2	64	IP23	E	0.8	120(250)
	SINUS 1130	2	8	1.2	64	IP23	MD	0.6	120(250)
S80	SINUS 1296	2	8	1.2	64	IP23	MD	0.6	120(250)
S90	SINUS 1800	2	8	3.6	64	IP23	V	0.45	70(2/0)
	SINUS 2076	2	12	1.2	64	IP23	ME	0.4	120(250)

Applications with DUTY CYCLE 50% - Class 6T

Size	Sinus Penta Model	Braking Unit		Braking Resistors					Wire Cross-section mm ² (AWG or kcmils)
		Q.ty	Q.ty	Recommended Value (Ω)	Power (kW)	Degree of Protection	Type of connection	Value (Ω)	
S65	SINUS 0457	1	6	2.4	64	IP23	E	1.6	95(4/0)
	SINUS 0524	1	8	2.8	64	IP23	F	1.4	70(2/0)
	SINUS 0598	1	8	2.8	64	IP23	F	1.4	70(2/0)
	SINUS 0748	1	8	2.4	64	IP23	F	1.2	95(4/0)
S70	SINUS 0831	1	10	2.4	64	IP23	G	0.96	95(4/0)
S75	SINUS 0964	1	12	2.4	64	IP23	H	0.8	70(2/0)
	SINUS 1130	2	16	2.4	64	IP23	MF	0.6	95(4/0)
S80	SINUS 1296	2	16	2.1	64	IP23	MF	0.52	120(250)
S90	SINUS 1800	2	20	2.4	64	IP23	MG	0.48	95(4/0)
	SINUS 2076	2	24	2.4	64	IP23	MH	0.4	70(2/0)

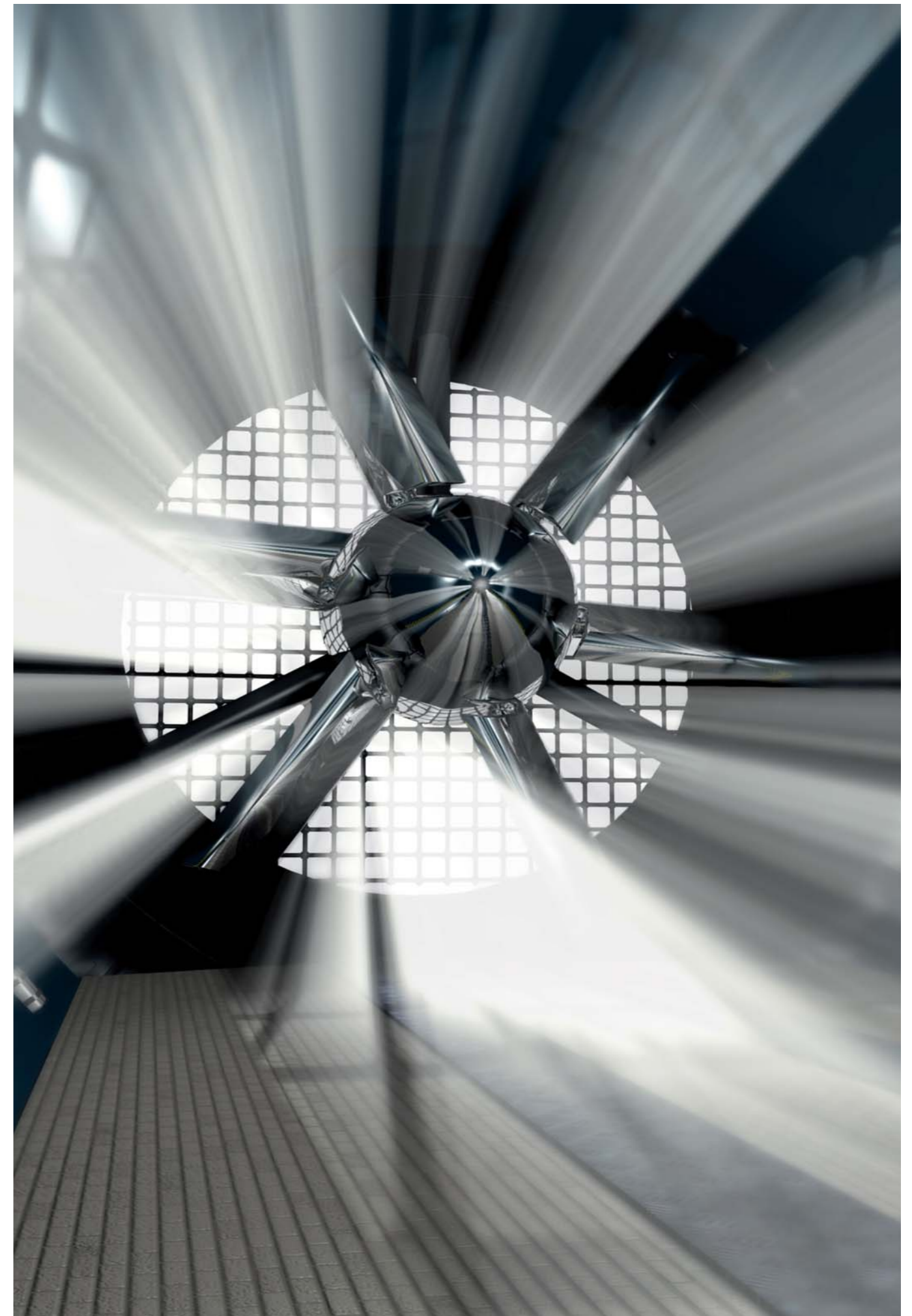

OPTIONAL BOARDS

A full range of optional boards for Sinus Penta; the right solution for every application

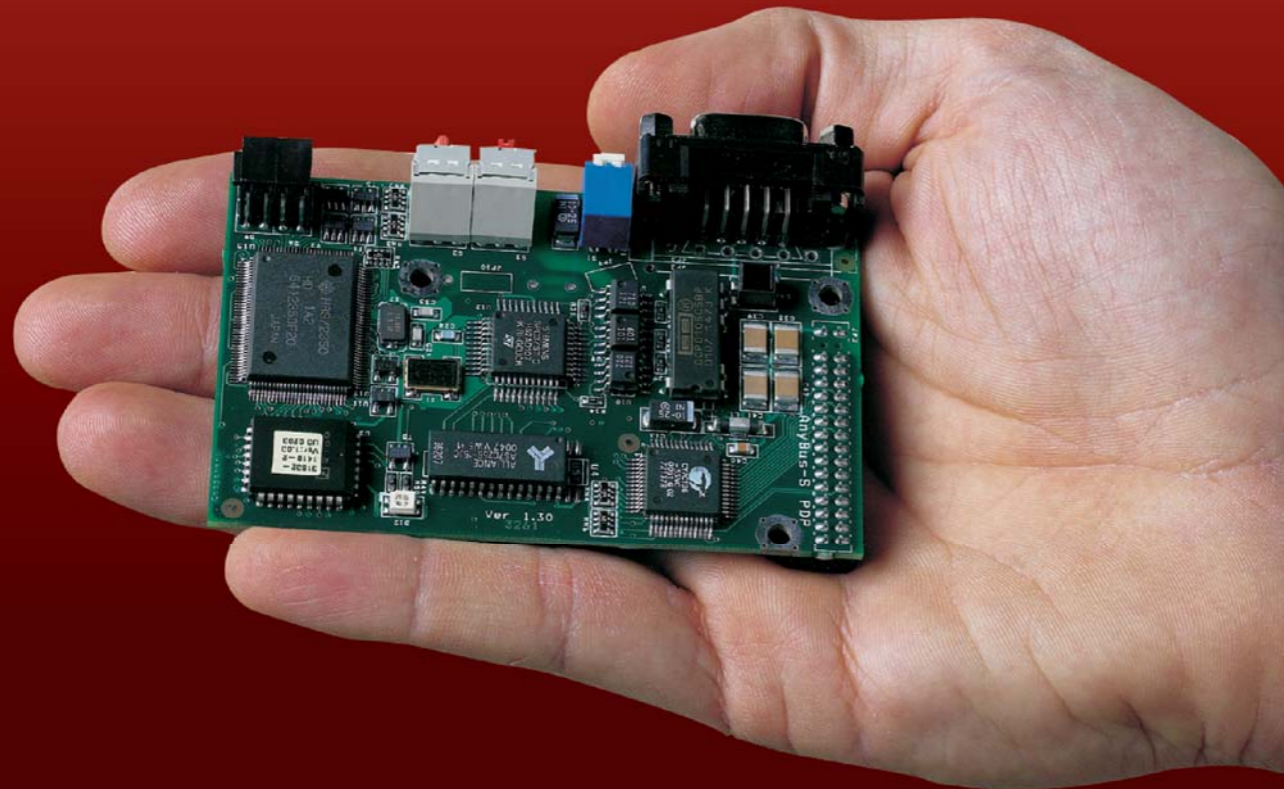

SINUS PENTA OPTIONAL BOARDS

Fieldbus and communication boards for SINUS PENTA

- ES822 Insulated board, RS232 and/or RS485 (this board must be installed on the inverter and it is suggested for ModBus networks)
- Profibus DP board (hardware and software kit)
- PROFIdrive board (hardware and software kit)
- DeviceNet board (hardware and software kit)
- CANOpen board (hardware and software kit)
- Interbus board (hardware and software kit)
- Lonworks (hardware and software kit)
- Ethernet+IT board (hardware and software kit)
- ControlNet board (hardware and software kit)
- Metasys N2 ES919
- BacNet RS485 ES919
- BacNet Ethernet ES919

Speed sensors boards for SINUS PENTA

- ES836 Encoder board
- ES913 LINE DRIVER Encoder board
- ES860 SINcos board
- ES861 Resolver/Encoder board with repeated Encoder + 3 digital Inputs/Outputs
- ES950 EnDAT Encoder board
- ES950 BiSS Encoder board
- ES966 Hiperface Encoder board

I/O expansion boards for SINUS PENTA

- ES847/1 Board 8 Digital Inputs + 6 Transistor Outputs, 4 PT100 inputs up to 260°C, 1 Analog Voltage input, 1 Analog current input 0-20mA - for SINUS PENTA plus ADE Energy Counter for Regenerative (RGN) application
- ES870 Board, 8 Digital Inputs + 6 Relay Outputs for SINUS PENTA Regenerative application
- ES988 120V/240V Board, 8 Digital Inputs + 4 Relay Outputs

Datalogger and RTC boards for SINUS PENTA

- ES851 Data Logger Board, REMOTE DRIVE wireless connection, RS232 Full modem - GSM - Local Ethernet - RS485 multidrop for the connection of up to 15 inverters
- ES851 REAL TIME CLOCK
- ES851 Data Logger Board, REMOTE DRIVE wireless connection, RS232 Full modem - GSM - Local Ethernet, RS485 multidrop for the connection of up to 15 inverters

Optional boards slots on the Sinus Penta CPU board

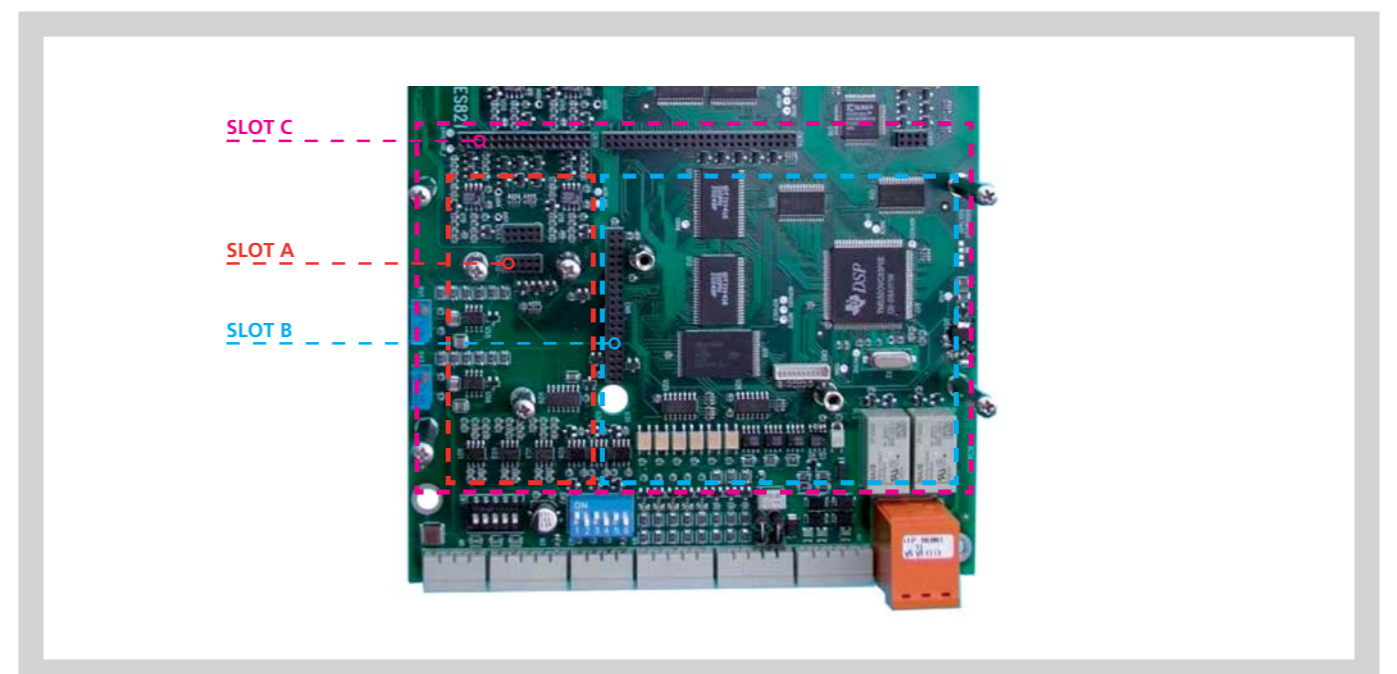

FIELD BUS COMMUNICATION BOARDS

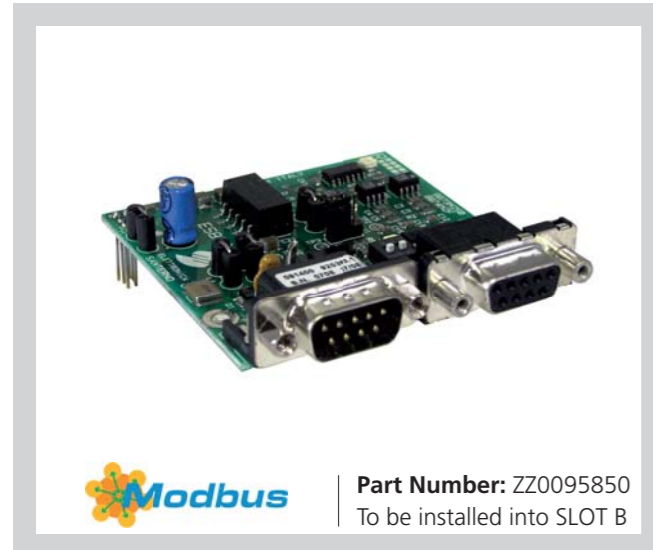

ES822 ISOLATED SERIAL BOARD

The isolated serial board RS232/485 controlling SINUS PENTA inverters allows connecting a computer through RS232 interface or allows a multidrop connection of Modbus devices through RS485 interface. It provides galvanic isolation of interface signals relating to both the control board ground and the terminal board common of the control board.



Part Number: ZZ0095850
To be installed into SLOT B



Part Number: ZZ4600055
To be installed into SLOT B

FIELD BUS COMMUNICATION BOARDS

DEVICENET® FIELD BUS BOARD

DeviceNet is a registered trademark of open DeviceNet Vendor Association.

The DeviceNet® communications board allows interfacing a Sinus PENTA drive with an external control unit through a communications interface using a CAN protocol of the DeviceNet 2.0 type. The baud rate and the MAC ID can be set through the on-board DIP-switches. Max. 512 bytes for input/output data are available; some of them are used for the interfacing with the inverter.

Main features:

- Baud Rate: 125, 250, 500 kbits/s
- DIP-switch for baud rate and MAC ID selection
- Optically isolated DeviceNet interface
- Max. 512 bytes for input & output data
- Max. 2048 bytes for input & output data through mailbox



Part Number: ZZ4600045
To be installed into SLOT B

PROFIBUS-DP® FIELD BUS BOARD

PROFIBUS-DP® is a registered trademark of PROFIBUS International.

The Profibus-DP communications board allows interfacing an inverter of the SINUS PENTA Series and an external control unit, such as a PLC, using a PROFIBUS-DP communications interface. The Sinus PENTA inverter operates as a Slave device and is controlled by a Master device (PLC) through command messages and reference values which are equivalent to the ones sent via terminal board.



Part Number: ZZ4600070
To be installed into SLOT B

CANOPEN® FIELD BUS BOARD

CANopen® and CiA® are registered trademarks of CAN in Automation e.V. The CANopen communications board allows interfacing a Sinus PENTA drive with an external control unit using communications interface operating with a CAN protocol of the CANopen type complying with the CIA DS-301 V3.0 specifications.

The baud rate and the Device Address can be set through the on-board rotary switches. Eight baud rate levels can be set, up to 1Mbit/s.

Main features:

- Unscheduled data exchange support
- Synch & Freeze operating mode
- Possibility of setting Slave Watch-dog timer
- Eight baud rate levels, from 10kbits/s to 1Mbit/s
- Possibility of setting different Device Addresses up to max. 99 nodes
- Optically isolated CAN interface
- CANopen conformity: CIA DS-301 V3.0

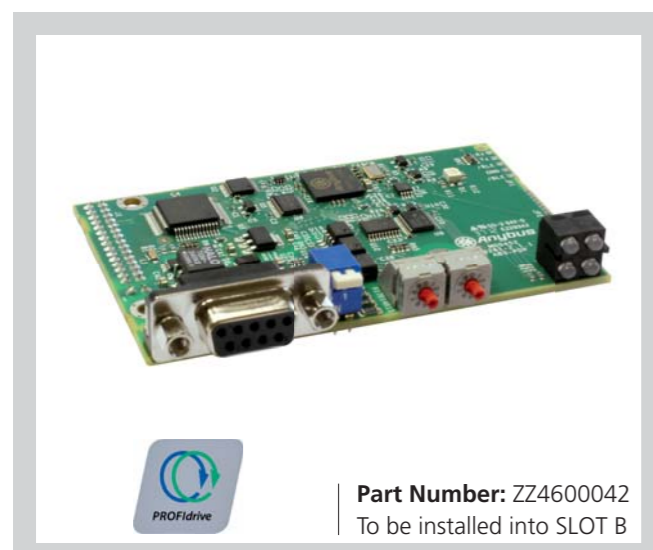

Part Number: ZZ4600042
To be installed into SLOT B

PROFIDRIVE® FIELD BUS BOARD

PROFdrive® is a registered trademark of PROFIBUS International.

The PROFdrive® communications board allows interfacing an inverter of the SINUS PENTA Series and an external control unit, such as a PLC, using a PROFdrive® communications interface. The PROFIBUS protocol family is specified in the IEC 61158 standard. The communication with a drive is defined in the PROFdrive Profile – The PROFIBUS Profile for Adjustable Speed Drives. For further information on PROFIBUS, refer to the above mentioned standards.

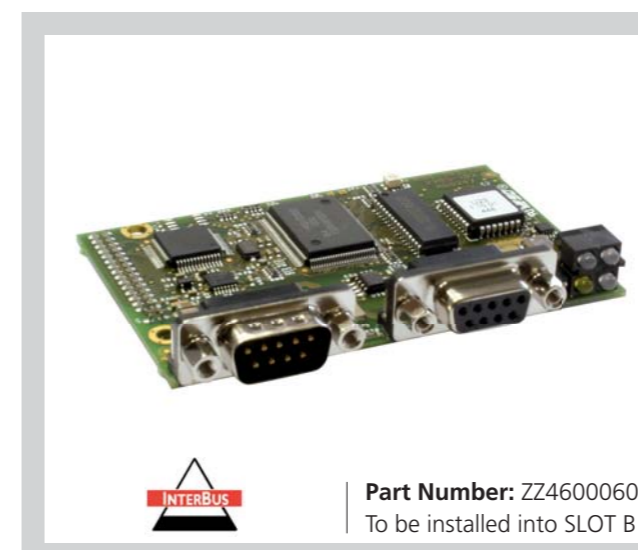

Part Number: ZZ4600060
To be installed into SLOT B

INTERBUS® FIELD BUS BOARD

The INTERBUS communications board allows interfacing a Sinus PENTA drive with an external control unit using communications interface operating with an INTERBUS protocol. INTERBUS is an open Fieldbus network, standardized in the International standard IEC 61158. INTERBUS is very popular in automobile production. Today, the installed base is > 6 Million INTERBUS nodes. INTERBUS products are certified by the INTERBUS club for interoperability and compatibility with the INTERBUS standards.

INTERBUS has been designed as a fast sensor / actuator network for transmitting cyclic process data in industrial environments. Due to its transmission procedure and its ring topology, INTERBUS offers excellent features like fast, cyclical and time-equidistant transmission, optimal diagnostics and easy installation procedures.

FIELD BUS COMMUNICATION BOARDS



LONWORKS® FIELD BUS BOARD

The LONWORKS communications board allows interfacing a Sinus PENTA drive with an external control unit using communications interface operating with a LONWORKS protocol. Lonworks networks can be found in all key building automation sub-systems including heating, ventilation, and air conditioning, lighting, boilers, air handlers, security, elevators, fire detection, access control, energy monitoring, irrigation control, and window blinds.



Part Number: ZZ4600085
To be installed into SLOT B

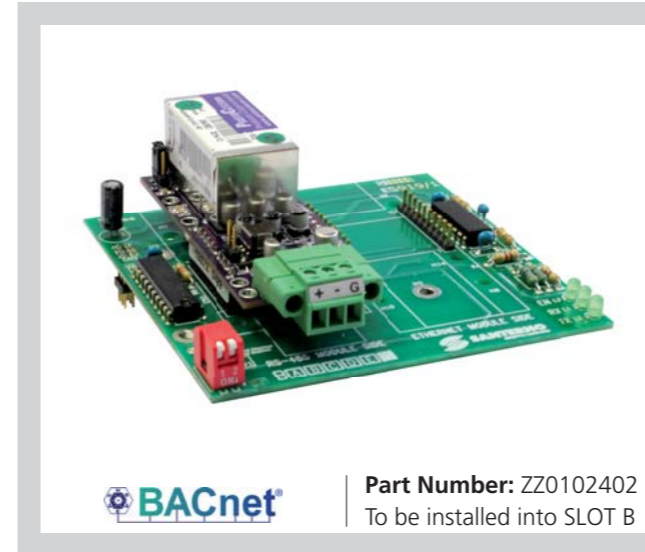

ES919 BACNET/RS485 BOARD

The BACnet/RS485 Module card uses RS485 serial port to communicate with the system via the BACnet MSTP communications protocol. The card is composed of the ProtoCessor FFP-485 module and of support/interface board ES919.



Part Number: ZZ0102402
To be installed into SLOT B

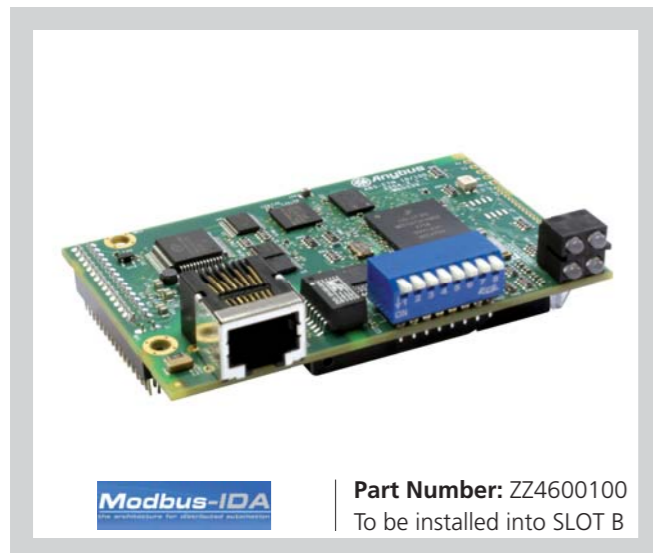

ETHERNET BOARD

Ethernet communications board allows interfacing a Sinus PENTA inverter to an external control unit with a communications interface operating with a Modbus/TCP Ethernet (IEEE 802) protocol complying with the Modbus-IDA V1.0 specifications. The IP rating for the communications board can be configured both through the on-board DIP-switches and automatically (network assignment through a DHCP protocol). The communications board performs automatic negotiation with the mains if the baud rate is set to 10 or 100 Mbits/s.



Part Number: ZZ4600100
To be installed into SLOT B

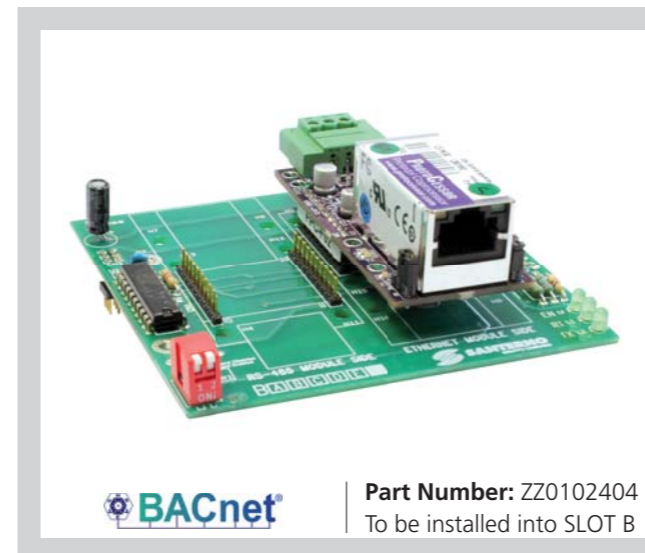

ES919 BACNET/ETHERNET BOARD

The Module BACnet/Ethernet board uses the Ethernet port to communicate with the system using the BACnet communications protocol. BACnet - A Data Communication Protocol for Building Automation and Control Networks. Developed under the auspices of the American Society of Heating, Refrigerating and Air-Conditioning Engineers (ASHRAE), BACnet is an American national standard, a European standard, a national standard in more than 30 Countries, and an ISO global standard (ISO 16484-5). The protocol is supported and maintained by ASHRAE Standing Standard Project Committee 135 (SSPC 135). Please see <http://www.bacnet.org>. This board is composed of the ProtoCessor FFP-485 communications module.



Part Number: ZZ0102404
To be installed into SLOT B

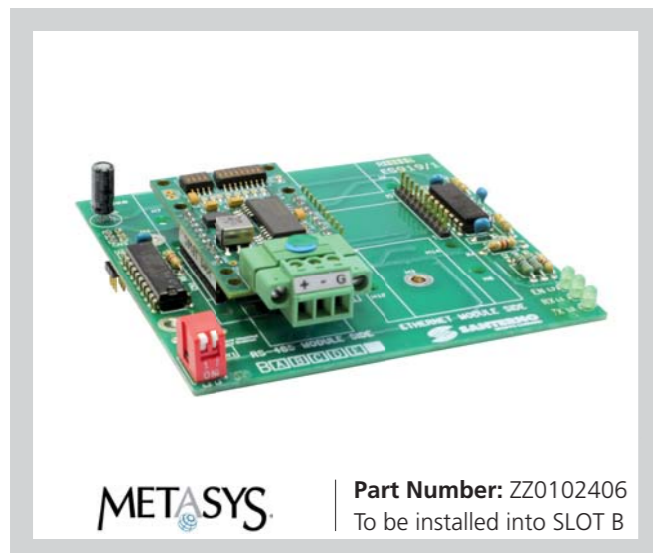

ES919 METASYS® N2 BOARD

Metasys is a registered trademark of Johnson Controls Inc. The ES919 BOARD communications board allows interfacing a Sinus PENTA drive with an external control unit using communications interface operating with a Metasys protocol. ES919 board for Metasys® N2 uses RS485 serial port to communicate with the system via the communication protocol "Metasys N2" by Johnson Controls (<http://www.johnsoncontrols.com>). ES919 board includes the ProtoCessor ASP-485 module.



Part Number: ZZ0102406
To be installed into SLOT B



POWER SUPPLY BOARDS

ES914 AUXILIARY POWER SUPPLY BOARD

ES914 provides insulated power supply to the inverters of the SINUS PENTA series through RS485 connector. It is supplied on a board-holder support with rear plug connector for DIN rail type OMEGA 35mm. ES914 board also provides insulation of RS485 signals on the inverter connector. 3-zone insulation is provided: the 24Vdc supply input section, the RS485 section on the Master side and RS485 + 9Vdc supply output on the inverter side are electrically isolated. ES914 board transmits data in just one direction at a time (half-duplex transmission). ES914 board is equipped with two indicator LEDs indicating RS485 communication failures. Wiring mismatch (if any) is also detected.

Part Number: ZZ0101790
To be installed outside the inverter

SPEED SENSORS BOARDS

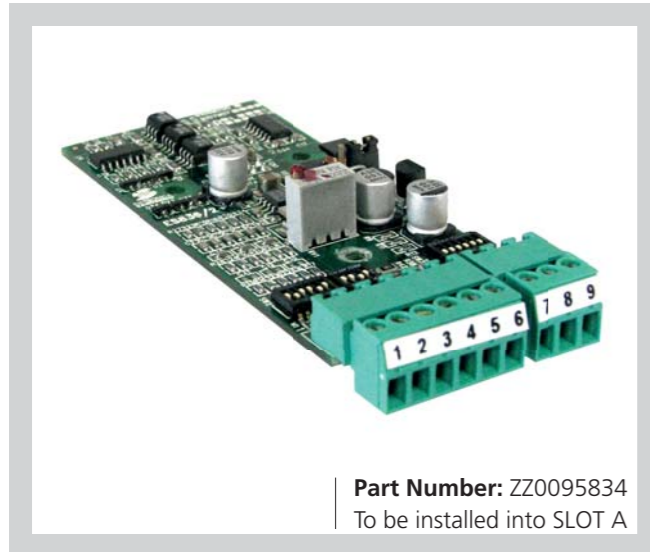

Part Number: ZZ0095834
To be installed into SLOT A

ES836 ENCODER BOARD

Board for incremental, bidirectional encoder to be used as a speed feedback for inverters of the SINUS series. It allows the acquisition of encoders with power supply ranging from 5 to 15VDC (adjustable output voltage) with complementary outputs (Line Driver, Push-Pull, TTL outputs). It can also be connected to 24VDC encoders with both complementary and single-ended push-pull or PNP/NPN outputs.

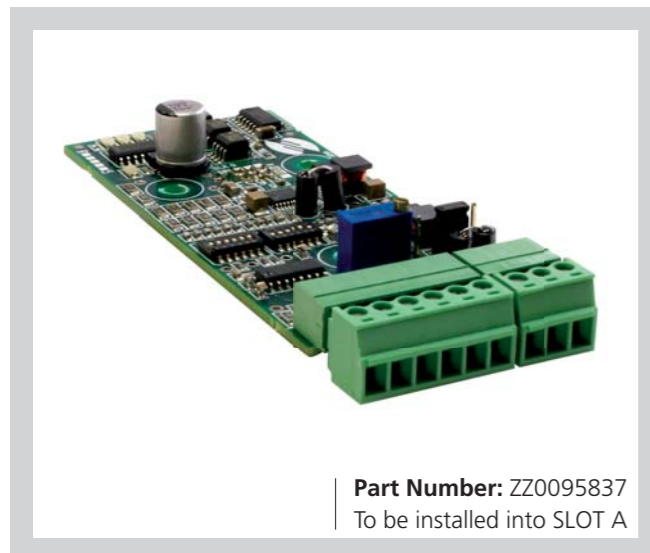

Part Number: ZZ0095837
To be installed into SLOT A

ES913 LINE DRIVER ENCODER BOARD

Board for incremental, bidirectional encoder to be used as a speed feedback for the inverters of the SINUS series. It allows the acquisition of encoders with power supply ranging from 5 to 24VDC (adjustable output voltage) with line driver outputs. The encoder board is to be installed into SLOT A.

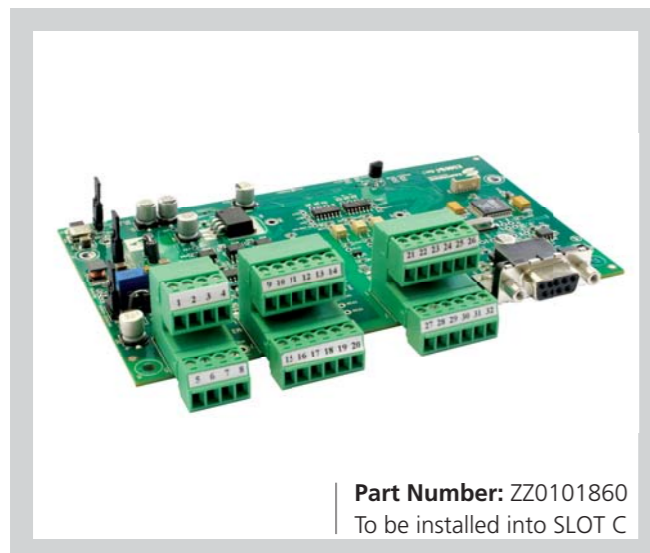

Part Number: ZZ0101860
To be installed into SLOT C

ES861 RESOLVER AND INCREMENTAL ENCODER BOARD

Board for resolver signals, it converts them into 12-bit digital signals that can be used as speed and/or position feedback for the inverters of the SINUS PENTA series. It also generates the sinusoidal signal for the resolver excitation and features dedicated logics for the acquisition of differential signals sent from incremental encoders and for the control of optoisolated digital inputs and outputs.

Main features:

- Resolver to Digital (RtD) conversion allowing selecting motor position readout or speed readout.
- Configurable frequency and gain of the excitation signal and the reading signals from the Resolver.
- Incremental encoder output generated from RtD to line-driver (TIA/EIA-422) at 1024 pps/rev, repeated also to the internal bus of the inverter.

SPEED SENSORS BOARDS

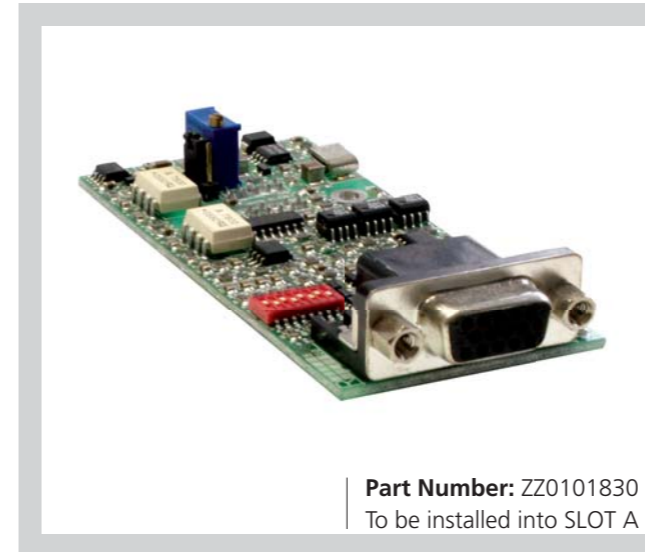

Part Number: ZZ0101830
To be installed into SLOT A

ES860 SIN/COS ENCODER BOARD

Board for encoders provided with 1Volt peak-to-peak analog outputs. To be used to provide speed feedback and/or position feedback for the inverters of the SINUS PENTA series.

Two acquisition modes as follows:

- **Three-channel mode:** increments low speed resolution and is suitable for slow rotation speed actuators requiring very accurate measurement of speed and position.
- **Five-channel mode:** detects the absolute mechanical position as soon as the inverter is first started up.

Main features:

- Two channels acquired via zero crossing and bidirectional digital counter with quadrature direction
- Zero index control for accurate alignment
- Two channels acquired in analog mode for absolute angle detection (12-bit resolution)

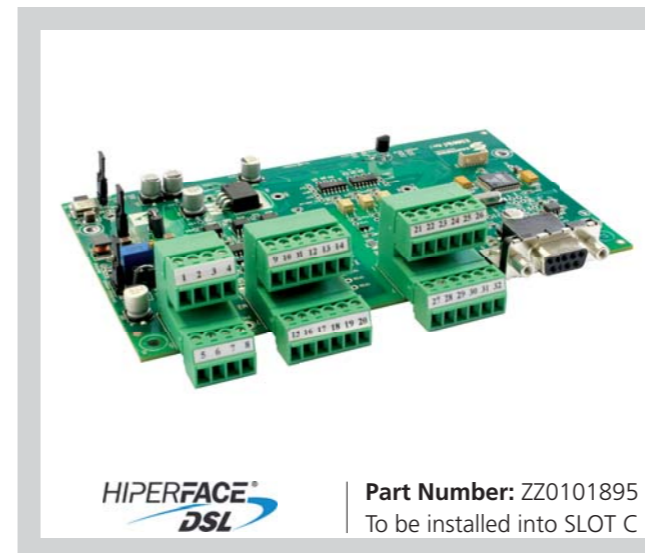

Part Number: ZZ0101895
To be installed into SLOT C

ES966 Hiperface ENCODER BOARD

HIPERFACE® is a registered trademark by SICK STEGMANN. The Hiperface Encoder Board allows users to connect single-turn or multi-turn encoders that have the HIPERFACE® interface to provide speed feedback and/or position feedback for the inverters of the Sinus PENTA series.

HIPERFACE® interface have been designed as Motor Feedback systems for drive technology. This results in compact design.

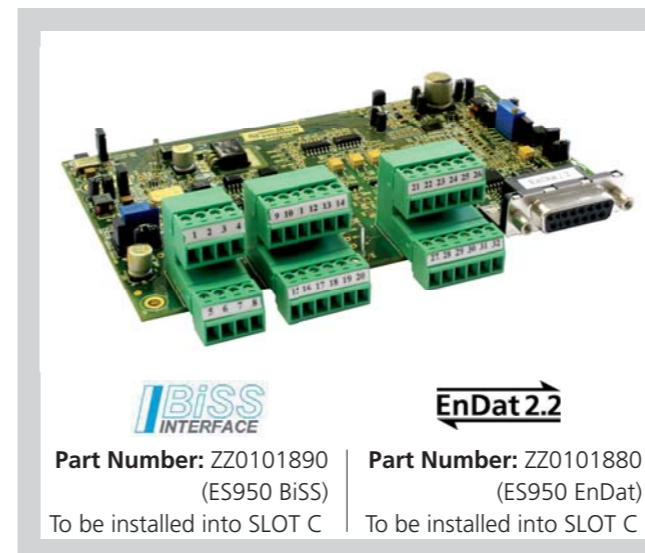

Part Number: ZZ0101890
(ES950 BiSS)
To be installed into SLOT C



Part Number: ZZ0101880
(ES950 EnDat)
To be installed into SLOT C

ES950 BiSS/EnDat ENCODER BOARD

The encoder board allows connecting absolute encoders with digital serial interface using mutually exclusive BiSS and EnDat 2.2 protocols and allows using them to provide speed feedback and/or position feedback for the inverters of the Sinus PENTA series.

The absolute measurement allows detecting the exact position of the motor as soon as the inverter is started, thus avoiding demanding alignment checks.

The ES950 board also features control logics for additional functions, such as the acquisition of differential incremental signals from external encoders and the control of optoisolated digital inputs/outputs.

DATALOGGER AND RTC BOARDS



Part Number: ZZ0101820
To be installed into SLOT B

ES851 DATA LOGGER BOARD

ES851 DataLogger is an option board allowing acquiring the operating variables of a plant and interfacing to a supervisor computer, even a remote computer, through different connecting modes for data logging and monitoring of the devices connected to the plant.

Main features:

- 8-Mb Data;
- RS485 and RS232 interface with Modbus-RTU protocol;
- Ethernet interface with TCP/IP protocol;
- Interface for the connection via GSM modem and analog modem with SMS functionality



Part Number: ZZ0101825
To be installed into SLOT B

ES851-RTC REAL TIME CLOCK BOARD

The Real Time Clock ES851 RTC option board is provided with a clock indicating date and operating even when the inverter is not powered.

The inverter firmware may use date and time info to manage different timed events.

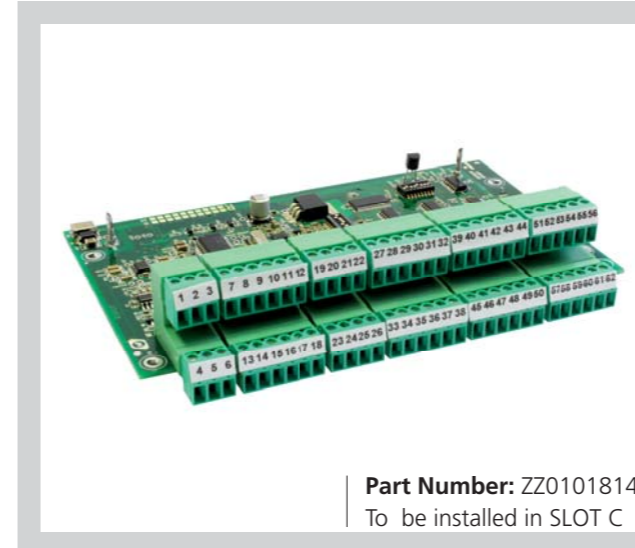

Part Number: ZZ0101814
To be installed in SLOT C

I/O EXPANSION BOARD

ES847 I/O EXPANSION BOARD

ES847 Board allows implementing an additional I/O set for any product of the PENTA series

Additional functionality includes:

- N.1 "fast" sampling analog inputs, 12-bit, $\pm 10V$ f.s.;
- N.2 "fast" sampling analog inputs, 12-bit, for AC current measure via CTs or for 0-20mA sensor measures; resolution: 11 bits;
- N.1 "fast" sampling analog input for $\pm 160mA$ f.s. sensor measures; resolution: 12 bits (Energy Counter option);
- N.4 "slow" sampling inputs, 12-bit, configurable as 0-10V f.s., 0-20 mA f.s., 0-100 mV f.s., temperature acquisition via two-wire thermistor PT100;
- N.2 "slow" sampling analog inputs, 12-bit, 0-10V f.s.;
- N.3 voltage inputs for ADE (Energy Counter option);
- N.3 current inputs for ADE (Energy Counter option);
- N.8 PNP, 24V multifunction digital inputs;
- N.6 multifunction digital outputs.

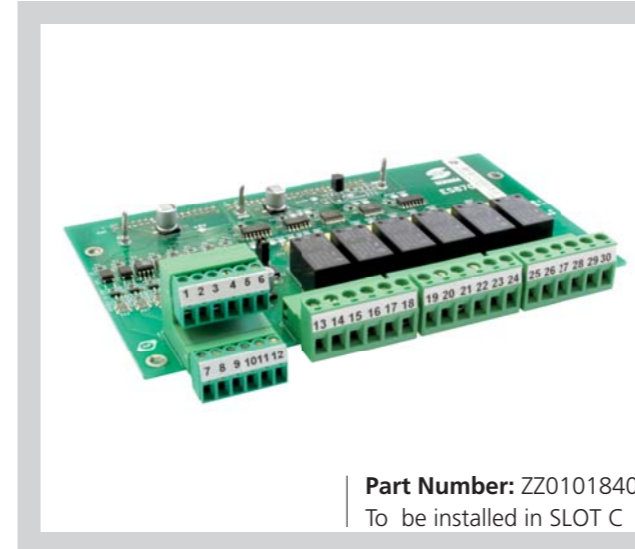

Part Number: ZZ0101840
To be installed in SLOT C

ES870 RELAY I/O EXPANSION BOARD

ES870 board is an expansion board for the digital I/Os of all the products of the SINUS PENTA series.

ES870 board includes:

- N.8 24V multifunction digital inputs, type PNP. Three inputs are "fast propagation" inputs that can be used also for PUSH-PULL 24V encoder acquisition;
- N.6 multifunction relay outputs

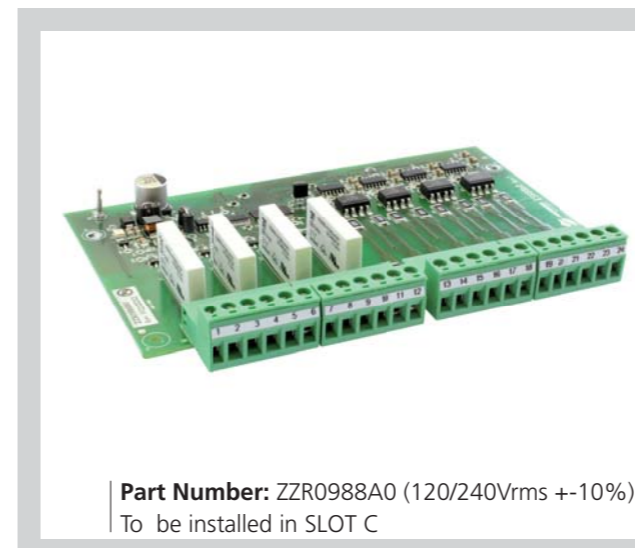

Part Number: ZZR0988A0 (120/240Vrms $\pm 10\%$)
To be installed in SLOT C

ES988 120V/240V I/O EXPANSION BOARD

ES988 board is an expansion board for the digital I/Os of all the products of the SINUS PENTA series.

ES988 board includes:

- N.8 multifunction digital inputs 120/240V
- N.4 multifunction relay outputs 120/240V



3 YEARS
WARRANTY

Vector modulation Lift Software for lift applications

- Wide power supply voltage range, 200Vac - 500Vac
- Input frequency 50 - 60Hz
- Power range 1.8 - 75 kW
- Full compatibility with the "REMOTE DRIVE" software for remote control

Technical features & highlights

- High comfort and precise positioning without feedback for application with speed up to 1.2m/sec.
- Possibility to use speed feedback for lift with speed up to 2.5m/sec.
- Totally noiseless operation given by carrier frequency up to 16kHz
- Overload 150-175% for 120sec.
- Included braking module.
- 2 line LCD display, 32 digit, remotable (Optional)
- 3 available speeds plus one speed for maintenance purposes
- Integrated multimeter
- Trip Log
- Integrated thermal protection for motor
- Automatic restart in case of inverter stop for alarm
- S curve with large choice of acceleration values and jerk
- Regulation of output frequency from 0 to 800 Hz
- 8 programmable inputs with regulation of internal timers
- 2 programmable relay outputs
- 1 open-collector output
- Auxiliary 24Vdc, 10Vdc
- 2 programmable analog outputs 0-10Vdc, 0(4)-20mA
- RS485 serial communication with MODBUS RTU protocol
- Compliant to lift directive EN 81
- EMC as per EN 5501 with integrated filters, type A1 for current ratings lower than 25A, and integrated filters type A2 for current over 25A

Optionals

- Emergency module EU850
- "Remote Drive" software
- Braking resistors
- Output filters
- Input and output chokes
- RS232/485 converter
- Remote keypad operation kit (5 metres)
- Potentiometer kit
- Kit for heatsink segregation
- Encoder card
- Converter for MODBUS/Profibus DP-CanBus-Device Net etc.

Product selection chart

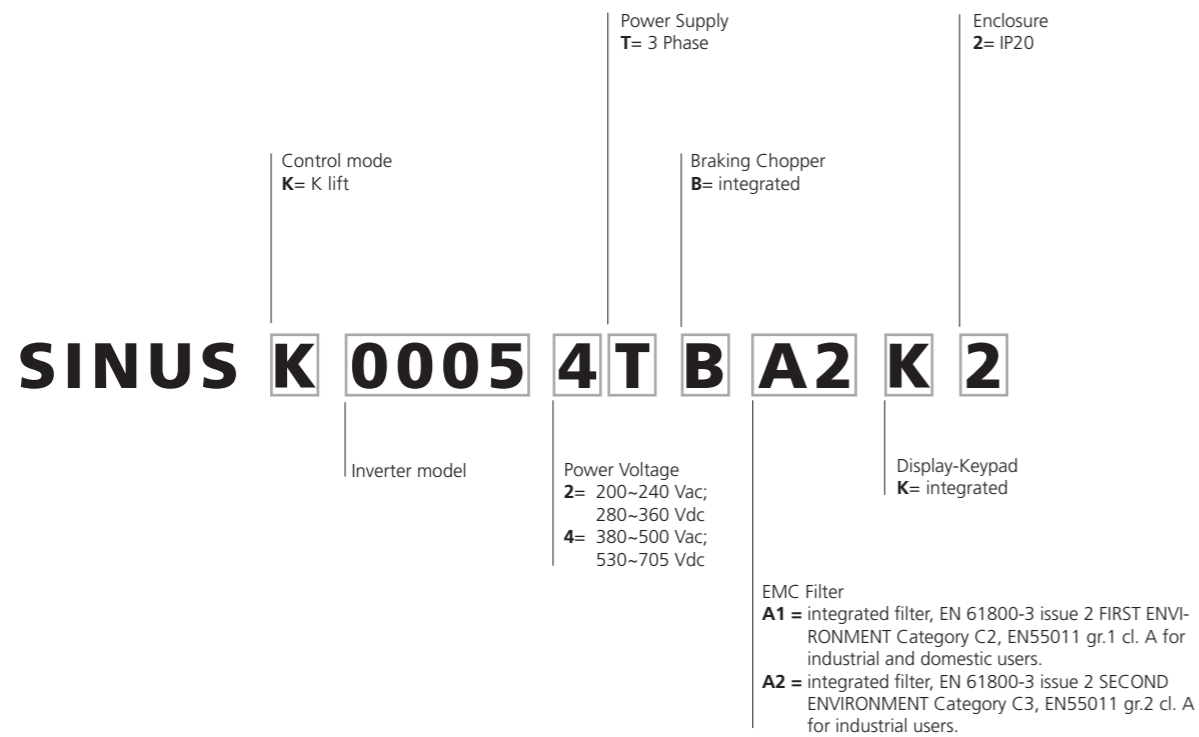

Model LIFT HEAVY overload up to 175% (120s)

Model	Applicable motor power								Inom. inverter A	Imax inverter A	model IP20	
	200-240Vac		380-415Vac		440-460Vac		480-500Vac				WxHxD	kg
	kW	HP	kW	HP	kW	HP	kW	HP				
Size S05												
SINUS 0005	-	-	3	4	3.7	5	4.5	6	10.5	11.5	170x340x175	7
SINUS 0007	1.8	2.5	4	5.5	4.5	6	5.5	7.5	12.5	13.5	170x340x175	7
SINUS 0008	2.2	3	-	-	-	-	-	-	15	16	170x340x175	7
SINUS 0009	-	-	4.5	6	5.5	7.5	7.5	10	16.5	17.5	170x340x175	7
SINUS 0010	3	4	-	-	-	-	-	-	17	19	170x340x175	7
SINUS 0011	-	-	5.5	7.5	7.5	10	9.2	12.5	16.5	21	170x340x175	7
SINUS 0013	3.7	5	-	-	-	-	-	-	19	21	170x340x175	7
SINUS 0014	-	-	7.5	10	9.2	12.5	11	15	16.5	25	170x340x175	7
SINUS 0015	4	5.5	-	-	-	-	-	-	23	25	170x340x175	7
SINUS 0016	4.5	6	-	-	-	-	-	-	27	30	170x340x175	7
SINUS 0020	5.5	7.5	-	-	-	-	-	-	30	36	170x340x175	7
Size S12												
SINUS 0016	-	-	9.2	12.5	11	15	12.5	17	27	30	215x401x225	12
SINUS 0017	-	-	9.2	12.5	11	15	12.5	17	30	32	215x401x225	12
SINUS 0020	-	-	11	15	15	20	15	20	30	36	215x401x225	12
SINUS 0023	7.5	10	-	-	-	-	-	-	38	42	215x401x225	11
SINUS 0025	-	-	15	20	18.5	25	18.5	25	41	48	215x401x225	12
SINUS 0030	-	-	18.5	25	22	30	22	30	41	56	215x401x225	12
SINUS 0033	11	15	-	-	-	-	-	-	51	56	215x401x225	12
SINUS 0034	-	-	22	30	25	35	28	38	57	63	215x401x225	12
SINUS 0036	-	-	25	35	30	40	30	40	60	72	215x401x225	12
SINUS 0037	15	20	-	-	-	-	-	-	65	72	215x401x225	12
Size S15												
SINUS 0038	15	20	25	35	30	40	30	47	65	75	225x466x331	22.5
SINUS 0040	15	20	25	35	30	40	34	47	72	75	225x466x331	22.5
SINUS 0049	18.5	25	30	40	37	50	43	58	80	96	225x466x331	22.5
Size S20												
SINUS 0049	18.5	25	30	40	37	50	43	58	80	96	279x610x332	33.2
SINUS 0060	22	30	37	50	45	60	51	69	88	112	279x610x332	33.2
SINUS 0067	25	35	45	60	50	70	56	76	103	118	279x610x332	33.2
SINUS 0074	30	40	48	65	55	75	69	93	120	144	279x610x332	36
SINUS 0086	32	45	55	75	65	90	74	100	135	155	279x610x332	36
Inverter power supply	200-240Vac; 280-360Vdc		380-500Vac; 530-705Vdc									

Key Inom= inverter nominal current • Imax= inverter maximum current for 120sec every 20min