



CONTENTS

Page	NMRV WORM GEARED MOTORS AND WORM GEAR UNITS
2	SUMMARIZE
3~4	MODEL MARK
5~8	RELEVANT PARAMETER
	TYPE SELECTION MANUAL
9	SELECTION EXAMPLE
10	THE CONFIGURATIN COMBINE RV SPEC WITH MOTORS COUPLING FLANGE AND RATIO
11	PC-NMRV COMBINATIONS
12	NMRV-RV/NRV-RV ASSIGEBMENT TABLE OF COMBINATION RATIO
13	PRESTAGE HELICAL GEARED UNITS(PC)
14	EFFICIENCY & IRREVERSIBILITY CHARACTER
15	MESH DATA
16~44	PERFORMANCE PARAMETER
45~63	OUTLINE DIMENSION SHEET
64	ACCESSORIES
	INSTALLATION
65~67	INSTALLATION POSITIONS DIAGRAM
68	INSTALLATION METHODS
	UDL SERIES STEPLESS SPEED VARIATOR
70	BRIEF INTRODUCTION TO STEPLESS SPEED VARIATOR
71	MODEL MARK
72	PERFORMANCE TABLE FOR UDL SERIES SPEED VARIATOR
73	OUTLINE & INSTALLATION SIZES FOR STEPLESS SPEED VARIATOR
74	INSTALLATION POSITIONS DIAGRAM
75	OPERATION & MAINTENANCE
	LUBRICANTS
77	NOTICE FOR ORDER
78	EXPLODED VIEW & NAME OF PARTS



Products guide



■ STRUCTURE FEATURES

NMRV series worm gear speed reducer is a new-generation of product developed by our company on the basis of perfecting WJ series products with a compromise of advanced technology both at home and abroad, its main features are as follows:

- 1.Made of high-quality aluminum alloy, light in weight and non-rusting.
- 2.Large in output torque.
- 3.Smooth in running and low in noise, can work long time in dreadful conditions.
- 4.High in radiating efficiency.
- 5.Good-looking in appearance, durable in service life and small in volume.
- 6.Suitable for omnibearing installation.

■ MAIN MATERIALS

- 1.Housing:die-cast aluminum alloy(frame size:025 to 090); cast iron(frame size:110 to 130).
- 2.worm: 20Cr,carbonize & quencher heat treatment make the hardness of gear's surface up to 56~62 HRC, retain carburization layer's thickness between 0.3 and 0.5mm after precise grinding.
- 3.worm wheel: wearable stannum bronze alloy.

■ SURFACE PAINTING

Aluminum alloy housing:

- 1.Shot blasting and special antiseptic treatment on the aluminum alloy surface.
- 2.After phosphating,paint with RAL5010 blue or RAL9010 silver.

Cast iron housing:

First paint with red antirust paint,then paint with RAL5010 blue or RAL9010 silver



■ NMRV/NRV WORM GEARED MOTORS AND WORM GEAR UNITS

NMRV 063 - 40 - E FA1 AS1 71B5 B3 - 7124/or 0.37 - 4 / 1



NO	Comments
1	Model code 1).NMRV: Hole input with flange 2).NRV: Shaft input without flange
2	Central distance of worm gear units(spec)
3	Speed ratio of reducer (i=7.5;10;15;20;25;30;40;50;60;80;100)
4	1).No mark means single extension worm shaft 2).E: Double extension worm shaft
5	1).No mark means without output flange 2).FA,FB,FC,FD,FE(1/2):output Flange and position
6	1).NO mark means hole output 2).AS(1/2):Single output shaft and position 3).AB: Double output shaft
7	Normalized form of input flange(without motor)
8	Installation position code
9	1).No mark means without motor 2).Model motors(poles of power)
10	Position diagram for motor terminal box default position 1 not to write out is ok

■ PC-NMRV WORM GEARS WITH PRE-STAGE HELICAL UNITS

PC 071 - NMRV 063 - 40 E FA1 AS1 B3



NO	Comments
1	Helical Pre-stage unit
2	Motor frame size
3	Model code 1).NMRV: Hole input with flange 2).NRV: Shaft input without flange
4	Central distance of worm gear units(spec)
5	Speed ratio of reducer(i=7.5;10;15;20;25;30;40;50;60;80;100)
6	1).No mark means single extension worm shaft 2).E: Double extension worm shaft
7	1).No mark means without output flange 2).FA,FB,FC,FD,FE(1/2):output Flange and position
8	1).NO mark means hole output 2).AS(1/2):Single output shaft and position 3).AB: Double output shaft
9	Installation position code

When ordering, you should show whether the reducers are equipped with motors, otherwise reducers are supplied with motors.

■ NMRV-NMRV/NRV-NMRV COMBINATION WORM GEAR UNITS

NMRV 050/110 - 900 - E FA1 AS1 71B5 B3



NO	Comments
1	Model code 1).NMRV: Hole input with flange 2).NRV: Shaft input without flange
2	Central distance of worm gear units(spec)
3	Speed ratio of reducer
4	1).No mark means single extension worm shaft 2).E: Double extension worm shaft
5	1).No mark means without output flange 2).FA,FB,FC,FD,FE(1/2):output Flange and position
6	1).NO mark means hole output 2).AS(1/2):Single output shaft and position 3).AB: Double output shaft
7	Normalized form of input flange
8	Installation position code

■ UDL-NMRV

COMBINATION OF STEPLESS SPEED VARIATOR AND WORM GEAR UNITS

UD L - 0.75 - NMRV 063 - 40 E FA1 AS1 B3

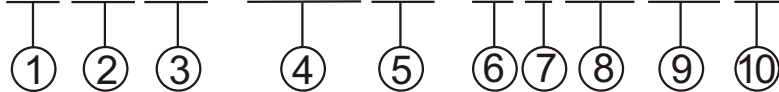

NO	Comments
1	Code of step less speed variator
2	Aluminium alloy housing, and no mark means cast iron casing
3	Relevant motor power
4	Code of worm gear units
5	Central distance of worm gear units(spec)
6	Speed ratio of worm gear units
7	1).No mark means single extension worm shaft 2).E: Double extension worm shaft
8	1).No mark means without output flange 2).FA,FB,FC,FD,FE(1/2):output Flange and position
9	1).NO mark means hole output 2).AS(1/2):Single output shaft and position 3).AB: Double output shaft
10	Installation position code

When ordering, you should show whether the reducers are equipped with motors, otherwise reducers aren't supplied with motors.

■ RELEVANT PARAMETER

1).Power

$$P_1 = \frac{P_2}{\eta_d} \text{ [KW]}$$

$$P_{1n} \geq P_1 \cdot f_s \text{ [KW]}$$

P_1 Input power
 P_2 Output power
 P_{1n} Selected motor power

The parameter can be found in the gearbox rating charts and represents the KW that can be safely transmitted to the gearbox, based on input speed n_1 and service factor $f_s=1$.

f_s Service factor
 η_d Dynamic efficiency

Values of η_d are calculated for gearboxes after a sufficiently long running-in period. After the running-in period the surface temperature in operation reduces and finally becomes stable. It may be worth highlighting that values of rated torque M_{2n} given in the catalogue take the dynamic efficiency η_d into consideration.

2). Rotation speed

n_1 Gear units input speed
 n_2 Gear units output speed

3). Transmission ratio I

$$I = \frac{n_1}{n_2}$$

4). Torque

$$M_2 = \frac{9550 \cdot P_1 \cdot \eta_d}{n_2} \text{ [Nm]}$$

$$M_{2n} \geq M_2 \cdot f_s \text{ [Nm]}$$

M_2 Output torque
 M_{2n} Selected output torque

The torque that can be transmitted continuously through the output shaft, with the gear unit operated under a service factor $f_s=1$. Rating is speed sensitive.

P_1 Input power
 η_d Dynamic efficiency
 f_s Service factor

5). Service factor f_s

The effect of the driven machine on the gear unit is taken into account to a sufficient level of accuracy using the service factor f_s . The service factor is determined according to the daily operating time and the starting frequency Z . Three load classifications are considered depending on the mass acceleration factor. You can read off the service factor applicable to your application in following figure. The service factor selected using this diagram must be less than or equal to the service factor as given in the performance parameter table.

Output shafts radial loads

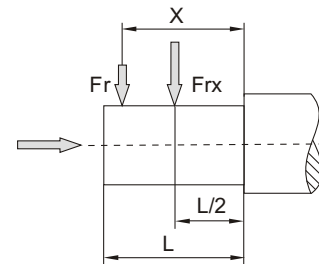

NMRV	025	030	040	050	063	075	090	110	130
a	50	65	84	101	120	131	162	176	188
b	38	50	64	76	95	101	122	136	148
Fr2 max	1350	1830	3490	4840	6270	7380	8180	12000	13500

Input shafts radial loads

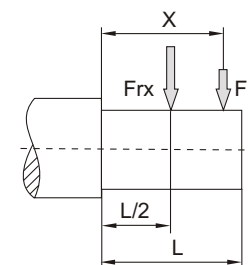

NRV	030	040	050	063	075	090	110	130
a	86	106	129	159	192	227	266	314
b	76	94.5	114	139	167	202	236	274
Fr1 max	210	350	490	700	980	1270	1700	2100

SELECTION EXAMPLE

1).Worm geared motors

Example:The input power of driver machine is 1.5KW, n1=1400r/min, heavy load, continuous running for 24 hours, the ambient temperature is +32°C, then choose the service factor, fs=1.7×1.2=1.904, n2=93.3r/min, B3 mounted SO:

$$i = \frac{n1}{n2} = \frac{1400}{93.3} = 15$$

$$P_{in} \geq P_1 \cdot f_s = 0.5 \times 1.904 = 0.952[kw]$$

Choose type:

NMRV075-15-B3-1.1-4

Count output torque:

$$M_2 = \frac{9550 \cdot P_1 \cdot \eta_d}{n_2} = \frac{9550 \cdot 0.5 \cdot 0.84}{93.3} = 43(NM)$$

$$M_{2n} = 95 \geq M_2 \cdot f_s = 43 \times 1.904 = 81.9[Nm]$$

2).Worm gear units

Example: Required torque 300Nm on driven machine, continuous running for 8 hours, uniform Load, the ambient temperature is 30°C, then choose the service factor fs=1.2x1.1=1.32, n1=900r/min. N2=22.5r/min.

$$M_{2n} \geq M_2 f_s = 300 \times 1.32 = 396[Nm]$$

$$i = \frac{n1}{n2} = \frac{900}{22.5} = 40$$

Choose type:

NRV090-40

THE CONFIGURATION COMBINE NMRV SPEC WITH MOTORS COUPLING FLANGE AND RATIO

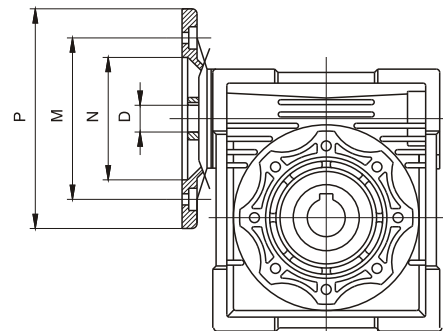

*If you want special key, please call our Technical Service

	Motor flange				The hole diameter of input shaft														
	PAM IEC	P	M	N	Transmission ratio														
					7.5	10	15	20	25	30	40	50	60	80	100				
NMRV025	56B14	80	65	50	9	9	9	9	9	9	9	9	9	9					
NMRV030	63B5	140	115	95															
	63B14	90	75	60	11	11	11	11	11	11	11	11							
NMRV040	56B5	120	100	80	9	9	9	9	9	9	9	9	9	9					
	56B14	80	65	50															
	71B5	160	130	110															
	71B14	105	85	70	14	14	14	14	14	14	14								
NMRV050	63B5	140	115	95															
	63B14	90	75	60	11	11	11	11	11	11	11	11	11	11	11				
	56B5	120	100	80									9	9	9	9			
	80B5	200	165	130	19	19	19	19	19	19									
NMRV063	80B14	120	100	80															
	71B5	160	130	110	14	14	14	14	14	14	14	14	14	14					
NMRV075	71B14	105	85	70															
	63B5	140	115	95									11	11	11	11			
NMRV090	90B5	200	165	130	24	24	24	24	24	24	24								
	90B14	140	115	95															
	80B5	200	165	130	19	19	19	19	19	19	19	19	19	19					
	80B14	120	100	80															
NMRV110	71B5	160	130	110								14	14	14	14	14			
	71B14	105	85	70															
	110/112B5	250	215	180	28	28	28												
	110/112B14	160	130	110															
NMRV130	90B5	200	165	130	24	24	24	24	24	24	24								
	90B14	140	115	95															
	80B5	200	165	130				19	19	19	19	19	19	19	19	19			
	80B14	120	100	80															
NMRV150	71B5	160	130	110								14	14	14	14	14			
	100/112B5	250	215	180	28	28	28	28	28	28									
	110/112B14	160	130	110															
	90B5	200	165	130	24	24	24	24	24	24	24	24	24	24	24	24	24	24	24
NMRV170	90B14	140	115	95															
	80B5	200	165	130															
	80B14	120	100	80															
	132B5	300	265	230	38*	38*	38*	38*											
NMRV190	110/112B5	250	215	180	28	28	28	28	28	28	28	28	28	28	28	28	28	28	28
	90B5	200	165	130															
	80B5	200	165	130															
	80B14	120	100	80															
NMRV210	132B5	300	265	230	38*	38*	38*	38*	38*	38*	38*								
	100/112B5	250	215	180															
	90B5	200	165	130															
	80B5	200	165	130															
NMRV230	132B5	300	265	230	38*	38*	38*	38*	38*	38*	38*								
	100/112B5	250	215	180															
	90B5	200	165	130															
	80B5	200	165	130															

PC-NMRV COMBINATIONS

	i	PC063		PC071		PC080			PC090			
		105/11 i=3	105/14 i=3	120/14 i=3	120/19 i=3	160/19 i=3	160/24 i=3	160/28 i=3	160/19 i=2.42	160/24 i=2.42	160/28 i=2.42	
NMRV040	25											
	30											
	40											
	50											
	60											
	80											
NMRV050	100											
	25											
	30											
	40											
	50											
	60											
NMRV063	80											
	100											
	25											
	30											
	40											
	50											
NMRV075	60											
	80											
	100											
	25											
	30											
	40											
NMRV090	50											
	60											
	80											
	100											
	25											
	30											
NMRV110	40											
	50											
	60											
	80											
	100											
	25											
NMRV130	30											
	40											
	50											
	60											
	80											
	100											

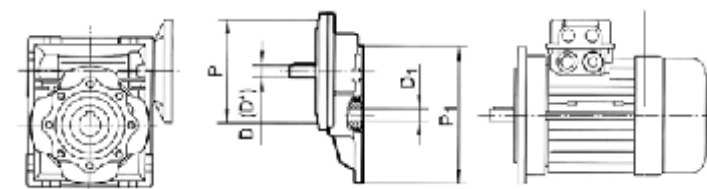

	P	P*	P ₁
PC 063	105/11	105/14*	63B5-140/11
PC 071	120/14	120/19*	71B5-160/14
PC 080	160/19	160/24* 160/28*	80B5-200/19
PC 090	160/24	160/19* 160/28*	90B5-200/24

*Only on request

■ NMRV-NMRV/NRV-NMRV
ASSIGNMENT TABLE OF COMBINATION RATIO

n1=1400r/min		NMRV025/030			NMRV025/040			NMRV030/040			NMRV030/050			NMRV030/063		
i	n2	P1 (Kw)	i025	i030	P1 (Kw)	i025	i040	P1 (Kw)	i(030)	i(040)	P1 (Kw)	i030	i050	P1 (Kw)	i030	i060
100	14	0.09	10	10	—	—	—	—	—	—	—	—	—	—	—	—
150	9.3	0.06	10	15	—	—	—	—	—	—	—	—	—	—	—	—
200	7	0.06	10	20	—	—	—	—	—	—	—	—	—	—	—	—
250	5.6	0.06	10	25	—	—	—	—	—	—	—	—	—	—	—	—
300	4.7	0.06	10	30	0.06	10	30	0.09	10	30	0.18	10	30	0.22	10	30
400	3.5	0.06	20	20	0.06	10	40	0.06	10	40	0.12	10	40	0.18	10	40
500	2.8	0.06	20	25	0.06	20	25	0.06	20	25	0.09	10	50	0.18	10	50
600	2.3	0.06	20	30	0.06	20	30	0.06	20	30	0.09	20	30	0.12	20	30
750	1.9	0.06	30	25	0.06	25	30	0.06	25	30	0.09	25	30	0.12	25	30
900	1.6	0.06	30	30	0.06	30	30	0.06	30	30	0.06	30	30	0.09	30	30
1200	1.2	0.06	40	30	0.06	40	30	0.06	40	30	0.06	40	30	0.09	40	30
1500	0.93	0.06	50	30	0.06	50	30	0.06	50	30	0.06	50	30	0.06	50	30
1800	0.78	0.06	60	30	0.06	60	30	0.06	60	30	0.06	60	30	0.06	60	30
2400	0.58	0.06	60	40	0.06	60	40	0.06	60	40	0.06	60	40	0.06	60	40
3000	0.47	0.06	60	50	0.06	60	50	0.06	—	—	0.06	60	50	0.06	60	50
3200	0.44	—	—	—	—	—	—	—	80	40	—	—	—	—	—	—
4000	0.35	—	—	—	0.06	50	80	0.06	80	50	0.06	80	50	0.06	80	50
4800	0.29	—	—	—	—	—	—	—	—	—	0.06	80	60	—	—	—
5000	0.28	—	—	—	0.06	50	100	0.06	50	100	—	—	—	0.06	100	50

n1=1400r/min		NMRV040/075			NMRV040/090			NMRV050/110			NMRV063/130		
i	n2	P1 (Kw)	i040	P1 (Kw)	i075	i040	i090	P1 (Kw)	i050	i110	P1 (Kw)	i063	i030
300	4.7	0.37	10	30	0.37	10	30	0.75	10	30	1.5	10	30
400	3.5	0.25	10	40	0.37	10	40	0.75	10	40	1	10	40
500	2.8	0.25	10	50	0.37	10	50	0.55	20	25	1	10	50
600	2.3	0.18	20	30	0.37	20	30	0.55	20	30	0.75	15	40
750	1.9	0.18	25	30	0.25	25	30	0.55	25	30	0.75	25	30
900	1.6	0.12	30	30	0.25	30	30	0.37	30	30	0.75	30	30
1200	1.2	0.12	40	30	0.18	40	30	0.25	40	30	0.55	40	30
1500	0.93	0.09	50	30	0.18	50	30	0.25	50	30	0.37	50	30
1800	0.78	0.09	60	30	0.12	60	30	0.25	60	30	0.37	60	30
2400	0.58	0.06	60	40	0.12	60	40	0.18	60	40	0.25	60	40
3000	0.47	0.06	60	50	0.09	60	50	0.12	60	50	0.25	60	50
4000	0.35	0.06	80	50	0.06	80	50	0.12	80	50	0.25	80	50
5000	0.28	0.06	100	50	0.06	100	50	0.12	100	50	0.25	100	50

You can choose 025,030,040,050,063,075,090,110,130as combination unit to combine according to the fact your special needs.

■ PRESTAGE HELICAL GEARED UNITS(PC)

The PC construction is modular and therefore it can be as a separate unit mounted on any type of fitted geared motor (PAM), whose the various possibilities of flange/output shafts can be found on page 11. Fitting the pre-stage helical module on the main reduction unit is easily done as for any motor of type B4 .The prestage unit cannot be used by itself, but only coupled with another reduction unit.

Materials

Case in aluminium alloy.

Gears: 20CrMo, machined accurately base on the accurate involute

Coupling to electric motor

Correctly fitting the pinion on the electric motor shaft requires you keep to the following instructions:

- Thoroughly clean the electric motor shaft.
- Remove the motor key from its seat.
- Fit the bush ① to the drive shaft as shown in the diagram. To make this easier, you can heat the bush to approximately 70/80°C
- Fit the new key ③ provided in place of the one removed beforehand.
- Fit the pinion ④ taking the same precautions as described in point
- Fit the washer ⑤ and tighten with the screw ⑥.
- Remove the rubber cap mounted on the seat of the oil seal, taking care since the pre—stage unit is already complete with lubricant.
- Fit the oil seal ② and then the motor assembly, taking care not to damage the lip of the oil seal.

N.B. For correct operation, with no vibration or noise, it is recommended to use good quality motors

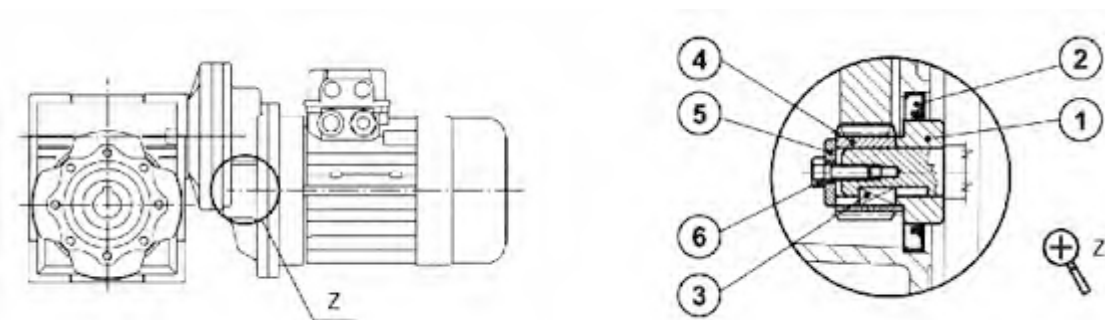

EFFICIENCY & IRREVERSIBILITY CHARACTER

Efficiency is an important parameter of reducer, Efficiency depends on the following parameters:

- 1) Helix angle of gearing,
- 2) Driving speed,
- 3) Running-in of gearing,
- 4) The performance of oil, oil seal and bearing.

The mesh data table on page 15 shows dynamic efficiency($\eta_d=1400$) and static efficiency values. Remember that these values are only achieved after the unit has been run in. Torque values Mn_2 indicated in the catalogue are calculated by considering the steady-state performance of the gearboxes. The actual values mentioned above may be have deflection.

Dynamic irreversibility

Dynamic irreversibility is achieved when the output shaft stops instantly when drive is no longer transmitted through the worm shaft. This condition requires a dynamic efficiency of $\eta_d < 0.4$ (see table on page 15).

Static irreversibility

Static irreversibility is achieved when the gear reducer at a standstill, the application of a load to the output shaft can't drive the worm shaft. This condition requires a static efficiency of $\eta_s < 0.5$ (see table on page 15).



η_d	>0.6	0.5~0.6	0.4~0.5	<0.4
DYNAMIC IRREVERSIBILITY	dynamic reversibility	Low dynamic reversibility	Good dynamic irreversibility	Dynamic irreversibility



η_s	>0.55	0.5~0.55	<0.5
STATIC IRREVERSIBILITY	Static reversibility	Low Static reversibility	Static irreversibility



The table shows approximate irreversibility classes. Vibrations and shocks can affect a gear reducer's irreversibility. As it is virtually impossible to provide and guarantee total non reversing, we recommend the use of an external brake with sufficient capability to prevent vibrations in duced starting, where these circumstances are required. For the irreversibility conditions of a combined geared unit one must consider that the efficiency of the group is given by the product of the efficiencies of each single reducer, i.e.: $\eta_{10} = \eta_1 \times \eta_2$



MESH DATA

	i	7.5	10	15	20	25	30	40	50	60	80	100
NMRV025	z_1	4	3	2	2	2	1	1	1	1		
	m_n	1.18	1.23	1.27	0.98	0.79	1.29	0.99	0.80	0.67		
	γ	25° 18'	19° 31'	13° 18'	11° 2'	9° 5'	6° 44'	5° 34'	4° 34'	3° 55'		
	η_d	0.85	0.83	0.79	0.76	0.73	0.68	0.64	0.59	0.56		
	η_s	0.71	0.67	0.60	0.56	0.52	0.45	0.41	0.36	0.33		
NMRV030	z_1	4	3	2	2	1	1	1	1	1	1	
	m_n	1.36	1.39	1.42	1.09	1.69	1.43	1.10	0.89	0.74	0.56	
	γ	18° 55'	14° 25'	9° 44'	7° 50'	5° 33'	4° 54'	3° 56'	3° 17'	2° 43'	2° 7'	
	η_d	0.84	0.81	0.76	0.72	0.66	0.64	0.59	0.54	0.50	0.44	
	η_s	0.66	0.62	0.54	0.49	0.41	0.38	0.33	0.29	0.26	0.21	
NMRV040	z_1	4	3	2	2	2	1	1	1	1	1	1
	m_n	1.87	1.95	2.00	1.54	1.26	2.04	1.55	1.27	1.06	0.80	0.65
	γ	23° 54'	18° 23'	12° 30'	10° 3'	8° 45'	6° 19'	5° 4'	4° 24'	3° 42'	2° 52'	2° 29'
	η_d	0.86	0.84	0.80	0.77	0.74	0.69	0.65	0.61	0.57	0.51	0.47
	η_s	0.70	0.66	0.59	0.54	0.51	0.44	0.39	0.36	0.32	0.27	0.24
NMRV050	z_1	4	3	2	2	2	1	1	1	1	1	1
	m_n	2.34	2.43	2.50	1.92	1.56	2.54	1.94	1.58	1.32	1.00	0.80
	γ	23° 49'	18° 19'	12° 27'	10° 3'	8° 33'	6° 18'	5° 4'	4° 18'	3° 38'	2° 52'	2° 17'
	η_d	0.87	0.85	0.81	0.78	0.75	0.71	0.67	0.63	0.59	0.53	0.48
	η_s	0.70	0.66	0.59	0.54	0.51	0.44	0.39	0.36	0.32	0.27	0.24
NMRV063	z_1	4	3	2	2	2	1	1	1	1	1	1
	m_n	2.96	3.08	3.17	2.44	1.98	3.23	2.47	1.99	1.68	1.27	1.02
	γ	24° 31'	18° 53'	12° 51'	10° 29'	8° 45'	6° 30'	5° 17'	4° 24'	3° 49'	2° 59'	2° 26'
	η_d	0.88	0.86	0.82	0.80	0.77	0.73	0.69	0.65	0.62	0.56	0.51
	η_s	0.70	0.66	0.59	0.55	0.51	0.44	0.40	0.36	0.33	0.28	0.24
NMRV075	z_1	4	3	2	2	2	1	1	1	1	1	1
	m_n	3.53	3.70	3.83	2.94	2.39	3.92	2.99	2.41	2.02	1.54	1.24
	γ	26° 38'	20° 37'	14° 5'	11° 19'	9° 29'	7° 9'	5° 43'	4° 46'	4° 1'	3° 17'	2° 44'
	η_d	0.88	0.87	0.84	0.81	0.79	0.76	0.72	0.68	0.64	0.59	0.55
	η_s	0.71	0.68	0.61	0.57	0.53	0.47	0.41	0.37	0.34	0.29	0.26
NMRV090	z_1	4	3	2	2	2	1	1	1	1	1	1
	m_n	4.23	4.47	4.66	3.6	2.93	4.79	3.67	2.97	2.49	1.89	1.52
	γ	29° 5'	22° 39'	15° 33'	12° 50'	10° 53'	7° 55'	6° 30'	5° 29'	4° 46'	3° 45'	3° 6'
	η_d	0.89	0.88	0.85	0.83	0.81	0.78	0.74	0.71	0.68	0.63	0.59
	η_s	0.72	0.69	0.63	0.59	0.56	0.49	0.44	0.41	0.37	0.32	0.28
NMRV110	z_1	4	3	2	2	2	1	1	1	1	1	1
	m_n	5.18	5.45	5.67	4.47	3.46	5.82	4.58	3.71	3.12	2.36	1.91
	γ	28° 15'	21° 57'	15° 2'	14° 42'	12° 33'	7° 39'	7° 29'	6° 21'	5° 33'	4° 27'	3° 46'
	η_d	0.89	0.88	0.86	0.85	0.83	0.79	0.77	0.74	0.72	0.67	0.63
	η_s	0.72	0.69	0.62	0.62	0.59	0.48	0.48	0.44	0.41	0.36	0.32
NMRV130	z_1	4	3	2	2	2	1	1	1	1	1	1
	m_n	6.11	6.45	6.72	5.24	4.28	6.91	5.36	4.35	3.65	2.76	2.23
	γ	28° 43'	22° 20'	15° 19'	13° 47'	11° 54'	7° 48'	6° 60'	6° 1'	5° 16'	4° 8'	3° 27'
	η_d	0.90	0.89	0.87	0.85	0.84	0.80	0.78	0.75	0.73	0.68	0.64
	η_s	0.72	0.69	0.63	0.61	0.58	0.49	0.46	0.43	0.40	0.34	0.30

P _{1n} [Kw]	n ₂ [1/min]	M _{2n} [Nm]	i	F _{r2} [N]	f _s			page
0.06 (5614)	186.7	2.6	7.5	503	4.2	NMRV025	5614	45
	140	3.4	10	553	3.5			
	93.3	4.9	15	633	2.5			
	70	6.2	20	697	2			
	56	7.5	25	751	1.8			
	46.7	8.3	30	798	1.6			
	35	10	40	878	1.3			
	28	12	50	946	0.9			
	23.3	14	60	1006	0.7			
	186.7	2.6	7.5	683	6.9			
140	3.3	10	752	5.4				
93.3	4.7	15	861	3.8				
70	5.9	20	948	3				
56	6.8	25	1021	3				
46.7	7.9	30	1085	2.5				
35	9.7	40	1194	1.9				
28	11	50	1286	1.5				
23.3	12	60	1367	1.3				
17.5	14	80	1504	0.9				
14	25	100	1620	1.3	NMRV025/030	5614	59	
9.3	33	150	1830	0.9				
7	41	200	1830	0.7				
5.6	45	250	1830	0.8				
4.7	56	300	3490	1.2	NMRV025/040	5614	59	
3.5	69	400	3490	0.9				
2.8	94	500	3490	0.7				
2.3	100	600	3490	0.6				
1.9	115	750	3490	0.5				
1.6	125	900	3490	0.5				
1.2	153	1200	3490	0.4				
0.93	185	1500	3490	0.3				
0.78	198	1800	3490	0.3				
0.58	247	2400	3490	0.2				
0.47	280	3000	3490	0.2				
0.35	295	4000	3490	0.1				
0.28	348	5000	3490	0.1				
4.7	55	300	3490	1.3	NMRV030/040	5614	60	
3.5	67	400	3490	0.9				
2.8	88	500	3490	0.6				
2.3	95	600	3490	0.7				
1.9	103	750	3490	0.6				
1.6	118	900	3490	0.5				
1.2	143	1200	3490	0.4				
0.93	166	1500	3490	0.4				
0.78	184	1800	3490	0.3				
0.58	217	2400	3490	0.2				
0.44	247	3200	3490	0.2				
0.35	278	4000	3490	0.1				
0.28	327	5000	3490	0.1				
1.6	118	900	4840	1	NJMRV030/050	5614	60	
1.2	143	1200	4840	0.7				
0.93	166	1500	4840	0.7				
0.78	184	1800	4840	0.7				
0.58	227	2400	4840	0.5				
0.47	256	3000	4840	0.4				
0.35	278	4000	4840	0.3				
0.29	316	4800	4840	0.3				

P _{1n} [Kw]	n ₂ [1/min]	M _{2n} [Nm]	i	F _{r2} [N]	f _s			page			
0.06 (5614)	0.93	173	1500	6270	1.1	NMRV030/063	5614	60			
	0.78	191	1800	6270	0.9						
	0.58	227	2400	6270	0.8						
	0.47	256	3000	6270	0.7						
	0.35	295	4000	6270	0.6						
	0.28	327	5000	6270	0.4						
	0.58	267	2400	7380	1.1				NMRV040/075	5614	61
	0.47	305	3000	7380	0.8						
	0.35	360	4000	7380	0.7						
	0.28	409	5000	7380	0.5						
0.47	329	3000	8180	1.4	NMRV040/090	5614	61				
0.35	393	4000	8180	1.3							
0.28	430	5000	8180	1							
0.09 (5612) (5624)	373.3	2.0	7.5	399	3.9	NMRV025	5612	45			
	280	2.6	10	439	3.4						
	186.7	3.8	15	503	2.4						
	140	4.9	20	553	1.9						
	112	5.9	25	590	1.5						
	93.3	6.7	30	633	1.3						
	70	8.5	40	697	1.1						
	56	10.0	50	751	0.9						
	186.7	3.9	7.5	503	2.8				NMRV025	5624	45
	140	5.1	10	553	2.4						
	93.3	7.3	15	633	1.6						
	70	9.3	20	697	1.3						
	56	11	25	751	1.2						
	46.7	13	30	798	1.1						
	35	16	40	878	0.9						
	373.3	2.0	7.5	542	6.5	NMRV030	5612	46			
	280	2.6	10	597	5						
	186.7	3.7	15	683	3.5						
	140	4.7	20	752	2.5						
	112	5.5	25	810	2.8						
93.3	6.4	30	861	2.3							
70	8.0	40	948	1.7							
56	9.4	50	1021	1.4							
46.7	10	60	1085	1.1							
35	13	80	1194	0.9							
186.7	3.9	7.5	683	4.6	NMRV030	5624	46				
140	5.0	10	752	3.6							
93.3	7.0	15	861	2.5							
70	8.8	20	948	2							
56	10	25	1021	1.9							
46.7	12	30	1085	1.7							
35	14	40	1194	1.2							
28	17	50	1286	1							
23.3	18	60	1367	0.9							
28	18	100	1286	1.6				NMRV025/030	5612	59	
18.7	25	150	1472	1.1							
14	31	200	1620	0.9							
14	37	100	1620	0.8	NMRV025/030	5624	59				
9.3	50	150	1830	0.6							
7	61	200	1830	0.5							
5.6	68	250	1830	0.5							
4.7	77	300	1830	0.4							
3.5	106	400	1830	0.3							
2.8	117	500	1830	0.3							

P1n [Kw]	n2 [1/min]	M2n [Nm]	i	Fr2 [N]	fs			page
0.09 (5612) (5624)	2.3	135	600	1830	0.2	NMRV025/30	5624	59
	1.9	149	750	1830	0.2			
	1.6	167	900	1830	0.2			
	1.2	201	1200	1830	0.1			
	0.93	231	1500	1830	0.1			
	0.78	264	1800	1830	0.1			
	0.58	311	2400	1830	0.1			
	0.47	347	3000	1830	0.1			
	28	19	50	2475	2	NMRV040	5624	47
	23.3	21	60	2630	1.7			
	17.5	25	80	2895	1.3			
	14	29	100	3118	1			
	9.3	43	300	3490	1.6	NMRV025/040	5612	59
	7	52	400	3490	1.2			
	5.6	71	500	3490	0.8			
	4.7	82	300	3490	0.8	NMRV030/040	5624	60
	3.5	103	400	4840	1.2			
	2.8	120	500	4840	1	NMRV030/050	5624	60
	2.3	146	600	4840	0.9			
	1.9	158	750	4840	0.8	NMRV030/063	5624	60
	1.6	177	900	4840	0.7			
	1.6	188	900	6270	1	NMRV030/063	5624	60
	1.2	222	1200	6270	0.9			
	0.93	259	1500	6270	0.7			
	0.93	305	1500	7380	1.1	NMRV040/075	5624	61
	0.78	331	1800	7380	1			
	0.58	400	2400	7380	0.7	NMRV040/090	5624	61
	0.47	494	3000	8180	0.9			
0.35	589	4000	8180	0.8				
373.3	2.7	7.5	399	3	NMRV025	5622	45	
280	3.5	10	439	2.6				
186.7	5.1	15	503	1.8				
140	6.5	20	553	1.4				
112	7.9	25	590	1.1				
93.3	9.0	30	633	1				
70	11	40	697	0.8				
186.7	5.2	7.5	683	3.4	NMRV030	6314	46	
140	6.6	10	752	2.7				
93.3	9.3	15	861	1.9				
70	12	20	948	1.5				
56	14	25	1021	1.5				
46.7	16	30	1085	1.3				
35	19	40	1194	0.9				
28	22	50	1286	0.8				
46.7	17	30	2087	2.6	NMRV040	6314	47	
35	21	40	2298	1.9				
28	25	50	2475	1.5				
23.3	28	60	2630	1.3				
17.5	33	80	2895	1				
14	38	100	3118	0.8				
18.7	42	75	2833	1.2				
15.6	46	90	3011	1.2	PC063-NMRV040	6314	55	
11.7	57	120	3314	0.9				
9.3	66	150	3490	0.7				
7.8	74	180	3490	0.6				
23.3	29	60	3610	2.3				
17.5	35	80	3973	1.9	NMRV050	6314	48	
14	39	100	4280	1.4				

P1n [Kw]	n2 [1/min]	M2n [Nm]	i	Fr2 [N]	fs			page		
0.12 (5622) (6314)	9.3	68	150	4840	1.3	PC063-NMRV050	6314	55		
	7.8	75	180	4840	1.1					
	5.8	88	240	4840	0.8					
	4.7	98	300	4840	0.7	NMRV030/050	6314	60		
	4.7	112	300	4840	1.2					
	3.5	138	400	4840	0.9					
	2.8	160	500	4840	0.7					
	5.8	92	240	6270	1.5					
	4.7	103	300	6270	1.2	PC063-NMRV063	6314	56		
	2.8	168	500	6270	1.3					
	2.3	199	600	6270	1.1	NMRV030/063	6314	60		
	1.9	217	750	6270	0.9					
	1.6	279	900	7380	1.2	NMRV040/075	6314	61		
	1.2	344	1200	7380	0.9					
	0.78	470	1800	8180	0.9	NMRV040/090	6314	61		
	0.58	593	2400	8180	0.9					
	0.47	731	3000	10320	1.2	NMRV050/110	6314	61		
	0.35	884	4000	10320	1					
0.28	1023	5000	10320	0.8						
373.3	4.0	7.5	542	3.2	NMRV030	6312	46			
280	5.2	10	597	2.5						
186.7	7.4	15	683	1.7						
140	9.5	20	752	1.3						
112	11	25	810	1.4						
93.3	13	30	861	1.1						
70	16	40	948	0.9						
186.7	7.7	7.5	683	2.3	NMRV030	6324	46			
140	10	10	752	1.8						
93.3	14	15	861	1.3						
70	18	20	948	1						
56	20	25	1021	0.9						
46.7	24	30	1085	0.8	NMRV040	6312	47			
93.3	14	30	1657	2.4						
70	17	40	1824	1.8						
56	21	50	1964	1.4						
70	19	20	1824	2				NMRV040	6324	47
56	23	25	1964	1.7						
46.7	25	30	2087	1.7						
35	32	40	2298	1.3						
28	37	50	2475	1						
23.3	42	60	2630	0.8	NMRV040	7116	47			
45	28	20	2113	1.5						
36	34	25	2276	1.3						
30	38	30	2419	1.3						
22.5	47	40	2662	1						
18.7	64	75	2833	0.8				PC063-NMRV040	6324	55
15.6	70	90	3011	0.8						
11.7	85	120	3314	0.6						
46.7	24	60	2865	2.1	NMRV050	6312	48			
35	30	80	3153	1.5						
28	34	100	3397	1.2	NMRV050	6324	48			
35	33	40	3153	2.3						
28	39	50	3397	1.9						
23.3	44	60	3610	1.6						
17.5	52	80	3973	1.2						
14	59	100	4280	0.9	NMRV050	7116	48			
18	56	50	3936	1.4						
15	63	60	4183	1.1						

P _{1n} [Kw]	n ₂ [1/min]	M _{2n} [Nm]	i	Fr ₂ [N]	f _s			page
0.18 (6312) (6324) (7116)	11.3	75	80	4604	0.9	NMRV050	7116	48
	18.7	64	75	3889	1.4	PC063-NMRV050	6324	55
	15.6	71	90	4132	1.5			
	11.7	87	120	4548	1.1			
	9.3	101	150	4840	0.9			
	7.8	113	180	4840	0.7			
	5.8	133	240	4840	0.6			
	12	95	75	4506	1.2	PC071-NMRV050	7116	56
	10	105	90	4788	1.4			
	7.5	126	120	4840	1			
	15	66	60	5467	2.1	NMRV063	7116	49
	11.3	79	80	6018	1.6			
	9	90	100	6270	1.4			
	9.3	103	150	6270	1.7	PC063-NMRV063	6324	56
	7.8	117	180	6270	1.4			
	5.8	139	240	6270	1			
	4.7	155	300	6270	0.8			
	12	97	75	5889	2.2	PC071-NMRV063	7116	56
	10	107	90	6259	2.4			
	7.5	131	120	6270	1.8			
	6	152	150	6270	1.4			
	5	168	180	6270	1.2			
	3.8	197	240	6270	0.9			
	3	218	300	6270	0.7			
	3.5	216	400	6270	1	NMRV030/063	6324	60
	2.8	252	500	6270	0.8			
	5	179	180	7380	1.7	PC071-NMRV075	7116	57
	3.8	211	240	7380	1.2			
	3	235	300	7380	1			
	2.3	336	600	7380	1.1	NMRV040/075	6324	61
1.9	371	750	7380	0.9				
1.6	419	900	7380	0.8				
1.2	544	1200	8180	1	NMRV040/090	6324	61	
0.93	647	1500	8180	0.8				
0.78	727	1800	10320	1.5	NMRV050/110	6324	61	
0.58	948	2400	10320	1.1				
0.25 (6322) (7114) (7126)	373.3	5.6	7.5	542	2.3	NMRV030	6322	46
	280	7.2	10	597	1.8			
	186.7	10	15	683	1.3			
	140	13	20	752	0.9			
	112	15	25	810	1			
	93.3	18	30	861	0.8			
	186.7	11	7.5	1315	3.6	NMRV040	7114	47
	140	14	10	1447	2.8			
	93.3	20	15	1657	1.9			
	70	26	20	1824	1.5			
	56	32	25	1964	1.2			
	46.7	35	30	2087	1.3			
	30	44	40	2298	0.9			
	120	17	7.5	1524	2.6	NMRV040	7126	47
	90	22	10	1677	2			
	60	31	15	1920	1.4			
	45	39	20	2113	1.1			
	36	48	25	2276	0.9			
	30	53	30	2419	0.9			
	35	42	80	3153	1.1	NMRV050	6322	48
	28	48	100	3397	0.8			
	70	27	20	2503	2.7	NMRV050	7114	48

P _{1n} [Kw]	n ₂ [1/min]	M _{2n} [Nm]	i	Fr ₂ [N]	f _s			page
0.25 (6322) (7114) (7126)	56	32	25	2696	2.2	NMRV050	7114	48
	46.7	36	30	2865	2.3			
	35	46	40	3153	1.7			
	28	54	50	3397	1.4			
	23.3	60	60	3610	1.1			
	17.5	72	80	3973	0.9			
	45	40	20	2900	1.9	NMRV050	7126	48
	36	48	25	3124	1.5			
	30	54	30	3320	1.7			
	22.5	67	40	3654	1.2			
	18	78	50	3936	1			
	15	88	60	4183	0.8			
	18.7	88	75	3889	1	PC071-NMRV050	7114	56
	15.6	98	90	4132	1.1			
	11.7	121	120	4548	0.8			
	28	55	50	4440	2.4	NMRV063	7114	49
	23.3	64	60	4719	2			
	17.5	76	80	5193	1.6			
	14	87	100	5595	1.4			
	18	81	50	5145	1.8	NMRV063	7126	49
	15	92	60	5467	1.5			
	11.3	110	80	6018	1.2			
	9	125	100	6270	1			
	18.7	91	75	5083	1.8	PC071-NMRV063	7114	56
	15.6	100	90	5401	2			
	11.7	125	120	5945	1.5			
	9.3	143	150	6270	1.2			
	7.8	163	180	6270	1			
	5.8	192	240	6270	0.7			
	4.7	215	300	6270	0.6			
12	135	75	5889	1.6	PC071-NMRV063	7126	56	
10	148	90	6259	1.8				
7.5	181	120	6270	1.3				
6	211	150	6270	1				
7	150	400	6270	1.4	NMRV030/063	6322	60	
5.6	175	500	6270	1.2				
17.5	80	80	6130	2.3	NMRV075	7114	50	
14	94	100	6603	1.9				
11.3	116	80	7103	1.7	NMRV075	7126	50	
9	133	100	7380	1.4				
9.3	151	150	7380	1.7	PC071-NMRV075	7114	57	
7.8	172	180	7380	1.4				
5.8	201	240	7380	1.1				
4.7	230	300	7380	0.9				
12	139	75	6952	2.4	PC071-NMRV075	7126	57	
10	155	90	7380	2.5				
7.5	191	120	7380	1.9				
6	219	150	7380	1.5				
5	248	180	7380	1.2				
3.5	321	400	7380	1.1	NMRV040/075	7114	61	
2.8	375	500	7380	0.8				
5	263	180	8180	1.9	PC071-NMRV090	7126	57	
3.8	318	240	8180	1.4				
3	358	300	8180	1.1				
2.3	488	600	8180	1.2	NMRV040/090	7114	61	
1.9	553	750	8180	0.9				
1.6	612	900	8180	0.8				
1.2	776	1200	10320	1.3	NMRV050/110	7114	61	

P _{1n} [Kw]	n ₂ [1/min]	M _{2n} [Nm]	i	F _{r2} [N]	f _s			page
0.25 (6322) (7114) (7126)	0.93	924	1500	10320	1.2			61
	0.78	1010	1800	10320	1.1			
	0.58	1358	2400	13500	1			62
	0.47	1626	3000	13500	0.8			
	0.35	1910	4000	13500	0.6			
0.28	2132	5000	13500	0.5				
0.37 (7112) (7124) (8016)	373.3	8.3	7.5	1044	3.3			47
	280	11	10	1149	2.6			
	186.7	16	15	1315	1.9			
	140	20	20	1447	1.4			
	112	25	25	1559	1.1			
	186.7	16	7.5	1315	2.4			47
	140	21	10	1447	1.9			
	93.3	30	15	1657	1.3			
	70	39	20	1824	1			
	56	47	25	1964	0.8			
	46.7	52	30	2087	0.8			
	112	25	25	2140	2			48
	93.3	29	30	2274	2.2			
	70	37	40	2503	1.6			
	56	44	50	2696	1.2			
46.7	50	60	2865	1				
35	62	80	3153	0.7				
140	21	10	1987	3.3			48	
93.3	31	15	2274	2.4				
70	39	20	2503	1.8				
56	47	25	2696	1.5				
46.7	54	30	2865	1.5				
35	68	40	3153	1.1				
28	80	50	3397	0.9				
23.3	89	60	3610	0.8				
120	25	7.5	2091	3.3			48	
90	33	10	2302	2.5				
60	47	15	2635	1.8				
45	59	20	2900	1.3				
36	72	25	3124	1				
30	80	30	3320	1.1				
35	70	40	4122	2.1			49	
28	82	50	4440	1.6				
23.3	94	60	4719	1.4				
17.5	113	80	5193	1.1				
14	129	100	5595	0.9				
45	60	20	3791	2.4			49	
36	73	25	4084	1.9				
30	82	30	4339	2.1				
22.5	102	40	4776	1.6				
18	120	50	5145	1.2				
15	137	60	5467	1				
18.7	134	75	5083	1.2			56	
15.6	148	90	5401	1.4				
11.7	185	120	5945	1				
9.3	212	150	6270	0.8				
9.3	182	300	6270	1.3				
7	222	400	6270	1				
23.3	97	60	5569	2			50	
17.5	119	80	6130	1.6				
14	139	100	6603	1.3				
18	124	50	6073	1.8				
18	124	50	6073	1.8				

P _{1n} [Kw]	n ₂ [1/min]	M _{2n} [Nm]	i	F _{r2} [N]	f _s			page
0.37 (7112) (7124) (8016)	15	141	60	6453	1.5			61
	11.3	172	80	7103	1.2			
	9	196	100	7380	1			
	18.7	138	75	6000	1.8			57
	15.6	154	90	6375	1.9			
	11.7	191	120	7017	1.5			
	9.3	223	150	7380	1.1			
	7.8	254	180	7380	0.9			
	12	206	75	6952	1.6			57
	10	230	90	7380	1.7			
	7.5	283	120	7380	1.3			
	6	324	150	7380	1			
	4.7	383	300	7380	1			61
	3.5	474	400	7380	0.7			
	11.3	184	80	7859	1.7			
9	212	100	8180	1.3				
7.8	268	180	8180	1.5			57	
5.8	321	240	8180	1.1				
4.7	371	300	8180	0.9				
6	347	150	8180	1.6			58	
5	389	180	8180	1.3				
3.8	471	240	8180	1				
4.7	406	300	8180	1.5			61	
3.5	505	400	8180	1.2				
2.8	593	500	8180	0.9				
2.3	722	600	8180	0.8				
3.8	509	240	10320	1.6			58	
3	577	300	10320	1.3				
1.9	837	750	10320	1.3				
1.6	928	900	10320	1.2				
1.2	1148	1200	10320	0.8				
0.93	1444	1500	13500	1.1			62	
0.78	1586	1800	13500	0.9				
373.3	12	7.5	1044	2.2				
280	16	10	1149	1.8			47	
186.7	24	15	1315	1.3				
140	30	20	1447	0.9				
112	37	25	1559	0.8				
140	31	20	1987	1.7				
112	38	25	2140	1.4			48	
93.3	43	30	2274	1.5				
70	55	40	2503	1.1				
56	65	50	2696	0.8				
46.7	74	60	2865	0.7				
186.7	24	7.5	1805	2.9			48	
140	32	10	1987	2.2				
93.3	46	15	2274	1.6				
70	59	20	2503	1.2				
56	70	25	2696	1				
46.7	80	30	2865	1				
120	37	7.5	2091	2.2			48	
90	48	10	2302	1.7				
60	69	15	2635	1.2				
45	88	20	2900	0.9				
70	56	40	3272	1.9				
56	68	50	3524	1.5			49	
46.7	78	60	3745	1.2				
35	96	80	4122	0.9				
35	96	80	4122	0.9				
35	96	80	4122	0.9				

P _{1n} [Kw]	n ₂ [1/min]	M _{2n} [Nm]	i	F _{r2} [N]	f _s			page
0.55 (7122) (8014) (8026)	28	111	100	4440	0.7	NMRV063	7122	49
	70	60	20	3272	2.2	NMRV063	8014	49
	56	72	25	3524	1.8			
	46.7	82	30	3745	1.9			
	35	104	40	4122	1.4			
	28	122	50	4440	1.1			
	23.3	140	60	4719	0.9			
	60	70	15	3444	2.2	NMRV063	8026	49
	45	90	20	3791	1.6			
	36	108	25	4084	1.3			
	30	123	30	4339	1.4			
	22.5	152	40	4776	1.1			
	35	99	80	4865	1.3	NMRV075	7122	50
	28	116	100	5241	1			
	35	108	40	4865	2	NMRV075	8014	50
	28	128	50	5241	1.6			
	23.3	144	60	5569	1.4			
	17.5	177	80	6130	1.1			
	14	206	100	6603	0.9			
	30	124	30	5122	2	NMRV075	8026	50
	22.5	156	40	5637	1.5			
	18	184	50	6073	1.2			
	15	210	60	6453	1			
	18.7	205	75	6000	1.2	PC080-NMRV075	8014	57
	15.6	230	90	6375	1.3			
	11.7	284	120	7017	1			
	9.3	332	150	7380	0.8			
	12	306	75	6952	1.1	PC080-NMRV075	8026	57
	10	341	90	7380	1.1			
	17.5	189	80	6783	1.5	NMRV090	8014	51
	14	221	100	7306	1.2			
	18	196	50	6719	2	NMRV090	8026	51
	15	224	60	7140	1.6			
	11.3	274	80	7859	1.1			
	9	315	100	8180	0.9			
	15.6	240	90	7054	2.3	PC080-NMRV090	8014	58
	11.7	297	120	7764	1.6			
	9.3	355	150	8180	1.3			
	7.8	398	180	8180	1			
	10	357	90	8174	2	PC080-NMRV090	8026	58
7.5	441	120	8180	1.4				
6	516	150	8180	1.1				
5	578	180	8180	0.9				
9.3	305	300	8180	2	NMRV040/090	7122	61	
7	375	400	8180	1.5				
5.6	441	500	8180	1.2				
175	201	80	8571	2.6	NMRV110	8014	52	
14	236	100	9232	2				
11.3	293	80	9931	1.9	NMRV110	8026	52	
9	344	100	10320	1.5				
7.8	425	180	10320	1.8	PC080-NMRV110	8014	58	
5.8	513	240	10320	1.3				
4.7	597	300	10320	1				
7.5	462	120	10320	2.6	PC080-NMRV110	8026	58	
6	552	150	10320	2				
5	620	180	10320	1.6				
3.8	756	240	10320	1.1				
4.7	615	300	10320	2	NMRV050/110	8014	61	

P _{1n} [Kw]	n ₂ [1/min]	M _{2n} [Nm]	i	F _{r2} [N]	f _s			page
0.55 (7122) (8014) (8026)	3.5	810	400	10320	1.4	NMRV050/110	8014	61
	2.8	938	500	10320	1.1			
	2.3	1096	600	10320	1			
	1.9	1244	750	10320	0.9			
	3.8	756	240	13500	1.6	PC080-NMRV130	8026	58
	3	858	300	13500	1.3			
	2.8	957	500	13500	1.6	NMRV063/130	8014	62
	1.9	1382	750	13500	1.2			
	1.2	2057	1200	13500	0.8			
	373.3	17	7.5	1433	3	NMRV050	8012	48
280	22	10	1577	2.4				
186.7	31	15	1805	1.7				
140	41	20	1987	1.3				
112	49	25	2140	1				
93.3	56	30	2274	1.1				
186.7	33	7.5	1805	2.1	NMRV050	8024	48	
140	43	10	1987	1.6				
93.3	62	15	2274	1.2				
70	80	20	2503	0.9				
140	43	20	2597	2.3	NMRV063	8012	49	
112	52	25	2797	1.8				
93.3	60	30	2973	2				
70	77	40	3272	1.4				
56	92	50	3524	1.1				
46.7	106	60	3745	0.9				
93.3	63	15	2973	2.2	NMRV063	8024	49	
70	82	20	3272	1.6				
56	98	25	3524	1.3				
46.7	112	30	3745	1.4				
35	141	40	4122	1				
120	51	7.5	2734	2.9	NMRV063	90S6	49	
90	67	10	3009	2.3				
60	96	15	3444	1.6				
45	123	20	3791	1.2				
36	147	25	4084	0.9				
30	167	30	4339	1				
46.7	107	60	4421	1.3	NMRV075	8012	50	
28	159	100	5241	0.8				
56	101	25	4160	2	NMRV075	8024	50	
46.7	117	30	4421	2				
35	147	40	4865	1.5				
28	174	50	5241	1.2				
23.3	197	60	5569	1				
60	97	15	4065	5.4	NMRV075	90S6	50	
45	124	20	4474	1.9				
36	149	25	4820	1.4				
30	170	30	5122	1.5				
22.5	213	40	5637	1.1				
18.7	280	75	6000	0.9	PC080-NMRV075	8024	57	
15.6	313	90	6375	1				
35	143	80	5383	1.6	NMRV090	8012	51	
28	169	100	5799	1.2				
28	182	50	5799	1.8	NMRV090	8024	51	
23.3	209	60	6163	1.5				
17.5	258	80	6783	1.1				
14	302	100	7306	0.9				
30	179	30	5667	2.6	NMRV090	90S6	51	
22.5	226	40	6238	1.8				

P _{1n} [Kw]	n ₂ [1/min]	M _{2n} [Nm]	i	F _{r2} [N]	f _s			page
0.75 (8012) (8024) (90S6)	18	267	50	6719	1.4	NMRV090	90S6	51
	15	306	60	7140	1.1			
	15.6	327	90	7054	1.7	PC080-NMRV090	8024	58
	11.7	405	120	7764	1.2			
	9.3	483	150	8180	0.9			
	7.8	543	180	8180	0.7			
	7	512	400	8180	1.1			
	5.6	601	500	8180	0.9	NMRV040/090	8012	61
	17.5	274	80	8571	1.9	NMRV110	8024	52
	14	322	100	9232	1.5			
	15	325	60	9023	2.1	NMRV110	90S6	52
	11.3	399	80	9931	1.4			
	9	470	100	10320	1.1			
	11.7	430	120	9811	2.2	PC080-NMRV110	8024	58
	9.3	506	150	10320	1.7			
	7.8	580	180	10320	1.3			
	5.8	700	240	10320	0.9			
	12.4	393	73	9614	3.2			
	9.3	508	96.8	10320	2.3	PC090-NMRV110	90S6	58
	7.4	607	121	10320	1.8			
	6.2	682	145.2	10320	1.5			
	4.6	832	193.6	10320	1	NMRV050/110	8012	61
	9.3	424	300	10320	2.8			
	7	553	400	10320	2.1			
	5.6	640	500	10320	1.6			
	4.7	838	300	10320	1.5			
	3.5	1105	400	10320	1.1	NMRV050/110	8024	61
	11.3	399	80	12989	2.1			
	9	470	100	13500	1.7			
	5.8	712	240	13500	1.4	PC080-NMRV130	8024	58
4.7	813	300	13500	1.1				
12.4	399	73	12575	4.4	PC090-NMRV130	90S6	58	
9.3	508	96.8	13500	3.2				
7.4	607	121	13500	2.6				
6.2	682	145.2	13500	2.1				
4.6	832	193.6	13500	1.5				
3.7	944	242	13500	1.2				
2.8	1305	500	13500	1.1				
2.3	1557	600	13500	1	NMRV063/130	8024	62	
1.9	1772	750	13500	0.9				
1.6	2014	900	13500	0.8				
373.3	25	7.5	1433	2.1				NMRV050
280	33	10	1577	1.6				
186.7	48	15	1805	1.2				
140	62	20	1987	0.9				
186.7	46	15	2359	2.1	NMRV063	8022	49	
140	60	20	2597	1.6				
112	72	25	2797	1.2				
93.3	82	30	2973	1.4				
70	104	40	3272	1				
120	75	7.5	2734	2	NMRV063	90L6	49	
90	98	10	3009	1.5				
60	140	15	3444	1.1				
45	180	20	3791	0.8				
186.7	50	7.5	2359	2.6	NMRV063	90S4	49	
140	65	10	2597	2				
93.3	92	15	2973	1.5				
70	120	20	3272	1.1				

P _{1n} [Kw]	n ₂ [1/min]	M _{2n} [Nm]	i	F _{r2} [N]	f _s			page
1.1 (8022) (90L6) (90S4)	56	144	25	3524	0.9	NMRV063	90S4	49
	46.7	164	30	3745	1			
	112	77	25	3302	1.9	NMRV075	8022	50
	93.3	89	30	3509	1.9			
	70	114	40	3862	1.4			
	56	137	50	4160	1.1			
	46.7	157	60	4421	0.9			
	90	98	10	3551	2.3	NMRV075	90L6	50
	60	142	15	4065	1.6			
	45	182	20	4474	1.3			
	36	219	25	4820	1			
	30	249	30	5122	1	NMRV075	90S4	50
	93.3	95	15	3509	2.1			
	70	122	20	3862	1.7			
	56	148	25	4160	1.3			
	46.7	171	30	4421	1.3			
	35	216	40	4865	1	NMRV090	8022	51
	35	210	80	5383	1.1			
	28	248	100	5799	0.8			
	36	228	25	5333	1.6			
	30	263	30	5667	1.8	NMRV090	90L6	51
	22.5	331	40	6238	1.2			
	18	391	50	6719	1			
	15	448	60	7140	0.8			
	35	222	40	5383	1.6			
	28	266	50	5799	1.3	NMRV090	90S4	51
	23.3	307	60	6163	1			
	22.5	345	40	7882	2.3	NMRV110	90L6	52
	18	414	50	8491	1.8			
	15	476	60	9023	1.4			
	11.3	586	80	9931	1			
	28	278	50	7328	2.3	NMRV110	90S4	52
	23.3	325	60	7787	1.9			
	17.5	402	80	8571	1.3			
	14	473	100	9232	1			
	12.4	576	73	9614	2.2	PC090-NMRV110	90L6	58
	9.3	746	96.8	10320	1.6			
	7.4	890	121	10320	1.2			
	6.2	1000	145.2	10320	1			
	19.3	392	73	8298	2.5	PC090-NMRV110	90S4	58
14.5	508	96.8	9133	1.8				
11.6	599	121	9838	1.5				
9.6	686	145.2	10320	1.1				
7.2	828	193.6	10320	0.8	NMRV050/110	8022	61	
9.3	621	300	10320	1.9				
7	810	400	10320	1.4				
5.6	938	500	10320	1.1				
11.3	586	80	12989	1.4				
9	689	100	13500	1.1	NMRV130	90L6	53	
17.5	408	80	11210	2.1				
14	480	100	12076	1.5	NMRV130	90S4	53	
12.4	585	73	12575	3				
9.3	746	96.8	13500	2.2				
7.4	890	121	13500	1.7				
6.2	1000	145.2	13500	1.4	PC090-NMRV130	90L6	58	
4.6	1220	193.6	13500	1				
19.3	398	73	10853	3.5				
14.5	508	96.8	11945	2.6				

P1n [Kw]	n2 [1/min]	M2n [Nm]	i	Fr2 [N]	f _s			page
1.1 (8022) (90L6) (90S4)	11.6	608	121	12868	2			58
	9.6	686	145.2	13500	1.6			
	7.2	843	193.6	13500	1.2			
	5.8	962	242	13500	0.9			
	4.7	1274	300	1500	1.3			
NMRV063/130	3.5	1621	400	13500	1			62
	2.8	1913	500	13500	0.8			
NMRV050	373.3	34	7.5	1433	1.5			48
	280	45	10	1577	1.2			
NMRV063	186.7	65	15	1805	0.9			49
	186.7	68	7.5	2359	1.9			
NMRV063	140	88	10	2597	1.5			49
	93.3	126	15	2973	1.1			
	70	164	20	3272	0.8			
	373.3	35	7.5	1873	2.7			
NMRV063	280	45	10	2061	2.1			49
	186.7	66	15	2359	1.6			
	140	86	20	2597	1.2			
	112	105	25	2797	0.9			
NMRV075	93.3	120	30	2973	1			50
	120	103	7.5	3227	2			
	90	134	10	3551	1.7			
NMRV075	60	193	15	4065	1.2			50
	140	89	10	3065	2.2			
	93.3	129	15	3509	1.5			
	70	166	20	3862	1.3			
NMRV075	56	202	25	4160	1			50
	46.7	233	30	4421	1			
	280	45	10	2433	3.1			
	186.7	66	15	2785	2.2			
NMRV075	140	86	20	3065	1.8			50
	112	105	25	3302	1.4			
	93.3	121	30	3509	1.4			
	70	156	40	3862	1			
NMRV090	56	187	50	4160	0.8			51
	46.7	215	60	4421	0.7			
	90	137	10	3929	2.7			
	60	198	15	4498	2.1			
NMRV090	45	258	20	4951	1.5			51
	36	310	25	5333	1.2			
	30	358	30	5667	1.3			
	70	170	20	4273	2.1			
NMRV090	56	207	25	4603	1.6			51
	46.7	239	30	4891	1.7			
	35	303	40	5383	1.2			
	28	363	50	5799	0.9			
NMRV090	23.3	418	60	6163	0.8			51
	56	197	50	4603	1.4			
	46.7	227	60	4891	1.1			
	45	264	20	6256	2.7			
NMRV110	36	322	25	6739	2.4			52
	30	363	30	7161	2.3			
	22.5	471	40	7882	1.7			
	18	565	50	8491	1.3			
NMRV110	15	649	60	9023	1.1			52
	35	315	40	6803	2.2			
	28	379	50	7328	1.7			
	23.3	443	60	7787	1.4			

P1n [Kw]	n2 [1/min]	M2n [Nm]	i	Fr2 [N]	f _s			page
1.5 (90S2) (90L4) (100L6)	17.5	548	80	8571	0.9			52
	46.7	236	60	6181	2			
	35	299	80	6803	1.3			
	28	358	100	7328	1			
	19.3	535	73	8298	1.9			
	14.5	693	96.8	9133	1.3			
	11.6	817	121	9838	1.1			
	9.6	936	145.2	10320	0.8			
	9.3	847	300	10320	1.4			
	7	1105	400	10320	1			
NMRV130	5.6	1279	500	10320	0.8			53
	22.5	471	40	10309	2.3			
	18	565	50	11105	1.8			
	15	659	60	11801	1.4			
	11.3	799	80	12989	1.1			
	17.5	557	80	11210	1.5			
	14	655	100	12076	1.1			
	19.3	542	73	10853	2.6			
	14.5	693	96.8	11945	1.9			
	11.6	830	121	12868	1.5			
PC090-NMRV130	9.6	936	145.2	13500	1.1			58
	7.2	1149	194	13500	0.8			
	9.3	878	300	13500	1.9			
	7	1105	400	13500	1.4			
	5.6	1305	500	13500	1.1			
	4.7	1737	300	13500	1			
	3.5	2210	400	13500	0.7			
	373.3	51	7.5	1873	1.8			
	280	66	10	2061	1.5			
	186.7	97	15	2359	1.1			
NMRV063	186.7	99	7.5	2785	1.8			49
	140	131	10	3065	1.5			
	93.3	189	15	3509	1			
	373.3	50	7.5	2210	2.5			
NMRV075	280	66	10	2433	2.1			50
	186.7	97	15	2785	1.5			
	140	126	20	3065	1.3			
	11.2	154	25	3302	1			
NMRV075	93.3	178	30	3509	0.9			50
	186.7	100	7.5	3081	2.9			
	140	132	10	3391	2.3			
	93.3	191	15	3882	1.9			
NMRV090	70	249	20	4273	1.4			51
	56	304	25	4603	1.1			
	46.7	351	30	4891	1.2			
	120	154	7.5	3570	2.2			
NMRV090	90	201	10	3929	1.8			51
	60	291	15	4498	1.4			
	45	378	20	4951	1			
	140	129	20	3391	2			
NMRV090	112	159	25	3653	1.6			51
	93.3	185	30	3882	1.7			
	70	237	40	4273	1.2			
	56	289	50	4603	0.9			
NMRV110	70	255	20	5399	2.5			52
	56	311	25	5816	2.2			
	46.7	355	30	6181	2			
	35	462	40	6803	1.5			

P _{1n} [Kw]	n ₂ [1/min]	M _{2n} [Nm]	i	Fr ₂ [N]	f _s			page			
2.2 (90L2) (100LA4) (112M6)	28	555	50	7328	1.2	NMRV110	100LA4	52			
	23.3	649	60	7787	1						
	90	203	10	4965	3.5	NMRV110	112M6	52			
	60	294	15	5684	2.6						
	45	388	20	6256	1.9						
	36	473	25	6739	1.6						
	30	532	30	7161	1.6						
	112	161	25	4616	3.1				NMRV110	90L2	52
	93.3	187	30	4905	3						
	70	243	40	5399	2.1						
	56	296	50	5816	1.7						
	46.7	346	60	6181	1.4	PC090-NMRV110	90L2	58			
	38.6	398	73	6502	2.1						
	28.9	516	96.8	7249	1.5						
	23.1	617	121	7809	1.2						
	35	468	40	8897	2.2				NMRV130	100LA4	53
	28	563	50	9584	1.7						
	23.3	658	60	10185	1.4	NMRV130	112M6	53			
	17.5	816	80	11210	1						
	36	473	25	8814	2.2						
	30	539	30	9366	2.1						
	22.5	691	40	10309	1.6						
	18	829	50	11105	1.2						
	15	966	60	11801	1						
	35	444	80	8897	1.3				NMRV130	90L2	53
	28	525	100	9584	1						
	38.6	409	73	8614	2.9	PC090-NMRV130	90L2	58			
	28.9	545	96.8	9481	2						
23.7	654	121	10213	1.6							
19.3	752	145.2	10853	1.3							
373.3	68	7.5	2210	1.9	NMRV075				100L2	50	
280	90	10	2433	1.6							
186.7	135	7.8	2785	1.4	NMRV075	100LB4	50				
140	178	10	3065	1.1							
93.3	258	15	3509	0.8							
373.3	70	7.5	2446	3				NMRV090	100L2	51	
280	92	10	2692	2.6							
186.7	137	7.5	3081	2.1	NMRV090	100LB4	51				
140	180	10	3391	1.7							
93.3	261	15	3882	1.4							
70	340	20	4273	1							
56	414	25	4603	0.8							
46.7	479	30	4891	0.9							
93.3	264	15	4905	2.5	NMRV110	100LB4	52				
70	348	20	5399	1.9							
56	425	25	5816	1.6							
46.7	485	30	6181	1.5							
35	630	40	6803	1.1							
28	757	50	7328	0.9							
120	210	7.5	4511	3.1				NMRV110	132S6	52	
90	277	10	4965	2.5							
60	401	15	5684	1.9							
45	528	20	6256	1.4							
56	430	25	7607	2.2	NMRV130	100LB4	53				
46.7	491	30	8084	2.1							
35	638	40	8897	1.6							
28	767	50	9584	1.3							
23.3	898	60	10185	1							

P _{1n} [Kw]	n ₂ [1/min]	M _{2n} [Nm]	i	Fr ₂ [N]	f _s			page
3.0 (100L2) (100LB4) (132S6)	17.5	1173	80	11270	0.8	NMRV130	100LB4	53
	90	277	10	6494	3.4			
	60	406	75	7434	2.6			
	45	528	20	8182	1.9			
	36	645	25	8814	1.6			
	30	735	30	9366	1.6			
	22.5	942	40	10309	7.2			
4.0 (112M2) (112M4) (132MA6)	373.3	91	7.5	2210	7.4	NMRV075	112M2	50
	280	120	70	2433	1.2			
	186.7	180	7.5	2785	1	NMRV075	112M4	50
	140	237	10	3065	0.8			
	373.3	93	7.5	2446	2.2	NMRV090	112M2	51
	280	123	10	2692	1.9			
	186.7	182	7.5	3081	1.6	NMRV090	112M4	51
	140	240	10	3391	1.3			
	93.3	348	15	3882	1			
	70	453	20	4273	0.8			
	140	240	10	4285	2.5	NMRV110	112M4	52
	93.3	352	15	4905	1.9			
	70	464	20	5399	1.4			
	56	566	25	5816	1.2			
	46.7	646	30	6181	1.1			
	120	280	7.5	4511	2.3			
	90	369	10	4965	1.9			
	60	535	15	5684	1.4			
	56	573	25	7607	1.6			
	46.7	654	30	8084	1.6	NMRV130	112M4	53
35	851	40	8897	1.2				
28	1023	50	9584	1				
23.3	1197	60	10185	0.8				
120	283	7.5	5901	3.1	NMRV130			
90	369	10	6494	2.6				
60	541	15	7434	2				
45	705	20	8182	1.5				
36	860	25	8814	1.2				
186.7	250	7.5	3893	2.2		NMRV110	132S4	52
140	330	10	4285	1.8				
93.3	484	15	4905	1.4				
70	638	20	5399	1				
140	334	10	5605	2.5	NMRV130	132S4	53	
93.3	490	15	6416	1.9				
70	638	20	7062	1.4				
56	788	25	7607	1.2				
46.7	900	30	8084	1.2				
35	1171	40	8897	0.9				
186.7	341	7.5	3893	1.6	NMRV110	132M4	52	
140	450	10	4285	1.3				
93.3	660	15	4905	1				
186.7	345	7.5	5092	2.1	NMRV130	132M4	53	
140	455	10	5605	1.8				
93.3	668	15	6416	1.4				
70	870	20	7062	1				
56	1074	25	7607	0.9				
46.7	1227	30	8084	0.8				
35	1596	40	8897	0.7				

■ NRV...(n1=2800)

M2n [Nm]	i	P1n [Kw]	n2 [1/min]	Fr2 [N]	Fr1 [N]		page
13	7.5	0.58	373.3	542	125	NRV030	54
13	10	0.45	280	597	140		
13	15	0.31	186.7	683	140		
12	20	0.23	140	752	146		
15	25	0.25	112	810	210		
15	30	0.21	93.3	861	210		
14	40	0.16	70	948	127		
12	50	0.12	56	1021	128		
12	60	0.1	46.7	1085	126		
11	80	0.08	35	1194	130		
27	7.5	1.2	373.3	1044	233	NRV040	54
30	10	1	280	1149	272		
31	15	0.72	186.7	1315	291		
29	20	0.52	140	1447	204		
28	25	0.42	112	1559	236		
34	30	0.44	93.3	1657	350		
31	40	0.32	70	1824	350		
30	50	0.26	56	1964	350		
27	60	0.21	46.7	2087	350		
25	80	0.16	35	2298	350		
22	100	0.12	28	2475	350		
52	7.5	2.3	373.3	1433	324	NRV050	54
53	10	1.8	280	1577	378		
57	15	1.3	186.7	1805	399		
53	20	0.95	140	1987	417		
51	25	0.75	112	2140	482		
65	30	0.82	93.3	2274	490		
59	40	0.59	70	2503	490		
53	50	0.45	56	2696	490		
50	60	0.37	46.7	2865	490		
45	80	0.27	35	3153	490		
40	100	0.21	28	3397	490		
92	7.5	4.0	373.3	1873	395	NRV063	54
96	10	3.2	280	2064	463		
101	15	2.3	186.7	2359	492		
97	20	1.7	140	2597	538		
91	25	1.3	112	2797	593		
120	30	1.5	93.3	2973	700		
113	40	1.1	70	3272	700		
102	50	0.83	56	3524	700		
96	60	0.68	46.7	3745	700		
86	80	0.49	35	4122	700		
74	100	0.37	28	4440	700		

■ NRV...(n1=2800)

M2n [Nm]	i	P1n [Kw]	n2 [1/min]	Fr2 [N]	Fr1 [N]		page
128	7.5	5.6	373.3	2210	560	NRV075	54
141	10	4.7	280	2433	703		
150	15	3.4	186.7	2785	727		
160	20	2.8	140	3065	872		
147	25	2.1	112	3302	980		
170	30	2.1	93.3	3509	980		
166	40	1.6	70	3862	980		
149	50	1.2	56	4160	980		
143	60	1.0	46.7	4421	980		
130	80	0.72	35	4865	980		
123	100	0.58	28	5241	980		
207	7.5	8.9	373.3	2446	715	NRV090	54
236	10	7.7	280	2692	900		
270	15	6.0	186.7	3081	1034		
258	20	4.4	140	3391	1120		
246	25	3.4	112	3653	1270		
311	30	3.7	93.3	3882	1270		
280	40	2.6	70	4273	1270		
263	50	2.0	56	4603	1270		
242	60	1.6	46.7	4891	1270		
229	80	1.2	35	5383	1270		
203	100	0.9	28	5799	1270		
386	7.5	16.6	373.3	3090	950	NRV110	54
433	10	14.1	280	3401	1194		
482	15	10.7	186.7	3893	1337		
475	20	8.0	140	4285	1485		
499	25	6.8	112	4616	1700		
552	30	6.5	93.3	4905	1700		
519	40	4.7	70	5399	1700		
498	50	3.7	56	5816	1700		
472	60	3.0	46.7	6181	1700		
398	80	2.0	35	6803	1700		
382	100	1.6	28	7328	1700		
514	7.5	22.1	373.3	4042	1190	NRV130	54
574	10	18.7	280	4449	1493		
669	15	14.7	186.7	5092	1725		
660	20	11	140	5605	1912		
660	25	9.0	112	6038	2100		
774	30	9.0	93.3	6416	2100		
727	40	6.5	70	7062	2100		
696	50	5.1	56	7607	2100		
638	60	4.0	46.7	8084	2100		
606	80	3.0	35	8897	2100		
525	100	2.2	28	9584	2100		

■ NRV...(n1=1400)

M _{2n} [Nm]	i	P _{1n} [Kw]	n ₂ [1/min]	F _{r2} [N]	F _{r1} [N]		page
18	7.5	0.41	186.7	683	150	NRV030	54
18	10	0.32	140	752	169		
18	15	0.23	93.3	861	169		
18	20	0.18	70	948	190		
20	25	0.18	56	1021	210		
20	30	0.15	46.7	1085	210		
18	40	0.11	35	1194	210		
17	50	0.09	28	1286	210		
16	60	0.08	23.3	1367	210		
12	80	0.05	17.5	1504	210		
40	7.5	0.9	186.7	1315	294	NRV040	54
40	10	0.69	140	1447	331		
39	15	0.48	93.3	1657	331		
39	20	0.37	70	1824	350		
38	25	0.3	56	1964	350		
44	30	0.31	46.7	2087	350		
41	40	0.23	35	2298	350		
37	50	0.18	28	2475	350		
35	60	0.15	23.3	2630	350		
33	80	0.12	17.5	2895	350		
29	100	0.09	14	3118	350		
71	7.5	1.6	186.7	1805	401	NRV050	54
70	10	1.2	140	1987	490		
73	15	0.88	93.3	2274	490		
72	20	0.68	70	2503	490		
69	25	0.54	56	2696	490		
83	30	0.57	46.7	2865	490		
77	40	0.42	35	3153	490		
73	50	0.34	28	3397	490		
68	60	0.28	23.3	3610	490		
64	80	0.22	17.5	3973	490		
52	100	0.16	14	4280	490		
126	7.5	2.8	186.7	2359	500	NRV063	54
129	10	2.2	140	2597	571		
134	15	1.6	93.3	2973	615		
131	20	1.2	70	3272	667		
131	25	1.0	56	3524	700		
164	30	1.1	46.7	3745	700		
143	40	0.76	35	4122	700		
133	50	0.6	28	4440	700		
130	60	0.51	23.3	4719	700		
119	80	0.39	17.5	5193	700		
118	100	0.34	14	5595	700		

■ NRV...(n1=1400)

M _{2n} [Nm]	i	P _{1n} [Kw]	n ₂ [1/min]	F _{r2} [N]	F _{r1} [N]		page
185	7.5	4.1	186.7	2785	700	NRV075	54
190	10	3.2	140	3065	830		
198	15	2.3	93.3	3509	851		
210	20	1.9	70	3862	980		
202	25	1.5	56	4160	980		
233	30	1.5	46.7	4421	980		
216	40	1.0	35	4865	980		
206	50	0.89	28	5241	980		
197	60	0.75	23.3	5569	980		
187	80	0.58	17.5	6130	980		
180	100	0.48	14	6603	980		
287	7.5	6.3	186.7	3081	900	NRV090	54
306	10	5.1	140	3391	1082		
357	15	4.1	93.3	3882	1257		
351	20	3.1	70	4273	1270		
332	25	2.4	56	4603	1270		
415	30	2.6	46.7	4891	1270		
363	40	1.8	35	5383	1270		
339	50	1.4	28	5799	1270		
307	60	1.1	23.3	6163	1270		
285	80	0.83	17.5	6783	1270		
270	100	0.67	14	7306	1270		
546	7.5	12	186.7	3893	1200	NRV110	54
588	10	9.8	140	4285	1463		
660	15	7.5	93.3	4905	1604		
649	20	5.6	70	5399	1700		
665	25	4.7	56	5816	1700		
727	30	4.5	46.7	6181	1700		
693	40	3.3	35	6803	1700		
656	50	2.6	28	7328	1700		
620	60	2.1	23.3	7787	1700		
512	80	1.4	17.5	8571	1700		
473	100	1.1	14	9232	1700		
747	7.5	16.1	186.7	5092	1500	NRV130	54
820	10	13.5	140	5605	1845		
917	15	10.3	93.3	6416	2070		
905	20	7.8	70	7062	2100		
931	25	6.5	56	7607	2100		
1047	30	6.4	46.7	8084	2100		
1043	40	4.9	35	8897	2100		
972	50	3.8	28	9584	2100		
928	60	3.1	23.3	10185	2100		
853	80	2.3	17.5	11210	2100		
742	100	1.7	14	12076	2100		

■ NRV...(n1=900)

M2n [Nm]	i	P1n [Kw]	n2 [1/min]	Fr2 [N]	Fr1 [N]		page
20	7.5	0.3	120	792	175	NRV030	54
20	10	0.24	90	871	197		
20	15	0.17	60	997	197		
19	20	0.13	45	1098	210		
23	25	0.14	36	1183	210		
21	30	0.11	30	1257	210		
21	40	0.09	22.5	1383	210		
19	50	0.07	18	1490	210		
18	60	0.06	15	1583	210		
14	80	0.04	11.3	1743	210		
43	7.5	0.65	120	1524	319	NRV040	54
44	10	0.5	90	1677	350		
45	15	0.36	60	1920	350		
44	20	0.28	45	2113	350		
44	25	0.23	36	2276	350		
48	30	0.23	30	2419	350		
44	40	0.17	22.5	2662	350		
43	50	0.14	18	2868	350		
38	60	0.11	15	3047	350		
37	80	0.09	11.3	3354	350		
33	100	0.07	9	3490	350		
81	7.5	1.2	120	2091	448	NRV050	54
83	10	0.94	90	2302	490		
84	15	0.67	60	2635	490		
76	20	0.48	45	2900	490		
76	25	0.39	36	3124	490		
91	30	0.42	30	3320	490		
83	40	0.31	22.5	3654	490		
78	50	0.25	18	3936	490		
74	60	0.21	15	4183	490		
66	80	0.16	11.3	4604	490		
56	100	0.12	9	4840	490		
151	7.5	2.2	120	2734	580	NRV063	54
152	10	1.7	90	3009	661		
153	15	1.2	60	3444	670		
149	20	0.91	45	3791	700		
135	25	0.69	36	4084	700		
176	30	0.79	30	4339	700		
160	40	0.58	22.5	4776	700		
146	50	0.45	18	5145	700		
137	60	0.37	15	5467	700		
127	80	0.29	11.3	6018	700		
125	100	0.25	9	6270	700		

■ NRV...(n1=900)

M2n [Nm]	i	P1n [Kw]	n2 [1/min]	Fr2 [N]	Fr1 [N]		page
212	7.5	3.1	120	3227	810	NRV075	54
223	10	2.5	90	3551	975		
232	15	1.8	60	4065	980		
232	20	1.4	45	4474	980		
219	25	1.1	36	4820	980		
249	30	1.1	30	5122	980		
236	40	0.83	22.5	5637	980		
217	50	0.65	18	6073	980		
206	60	0.54	15	6453	980		
200	80	0.43	11.3	7103	980		
191	100	0.36	9	7380	980		
336	7.5	4.8	120	3570	1040	NRV090	54
365	10	4.0	90	3929	1270		
410	15	3.1	60	4498	1270		
395	20	2.3	45	4951	1270		
372	25	1.8	36	5333	1270		
454	30	1.9	30	5667	1270		
422	40	1.4	22.5	6238	1270		
391	50	1.1	18	6719	1270		
350	60	0.86	15	7140	1270		
314	80	0.63	11.3	7859	1270		
281	100	0.49	9	8180	1290		
644	7.5	9.2	120	4511	1390	NRV110	54
702	10	7.6	90	4965	1700		
749	15	5.6	60	5684	1700		
722	20	4.1	45	6256	1700		
752	25	3.5	36	6739	1700		
847	30	3.5	30	7161	1700		
785	40	2.5	22.5	7882	1700		
753	50	2.0	18	8491	1700		
693	60	1.6	15	9023	1700		
586	80	1.1	11.3	9931	1700		
526	100	0.84	9	10320	1700		
871	7.5	12.3	120	5901	1740	NRV130	54
951	10	10.3	90	6494	2100		
1055	15	7.8	60	7434	2100		
1022	20	5.8	45	8182	2100		
1031	25	4.8	36	8814	2100		
1152	30	4.7	30	9366	2100		
1099	40	3.5	22.5	10309	2100		
1017	50	2.7	18	11105	2100		
923	60	2.1	15	11801	2100		
852	80	1.6	11.3	12989	2100		
751	100	1.2	9	13500	2100		

■ NRV...(n1=500)

M2n [Nm]	i	P1n [Kw]	n2 [1/min]	Fr2 [N]	Fr1 [N]		page
24	7.5	0.21	66.7	963	210	NRV030	54
24	10	0.16	50	1060	210		
24	15	0.12	33.3	1213	210		
23	20	0.09	25	1336	210		
29	25	0.1	20	1439	210		
26	30	0.08	16.7	1529	210		
24	40	0.06	12.5	1683	210		
22	50	0.05	10	1813	210		
20	60	0.04	8.3	1830	210		
17	80	0.03	6.3	1830	210		
53	7.5	0.45	66.7	1853	350	NRV040	54
53	10	0.35	50	2040	350		
56	15	0.26	33.3	2335	350		
52	20	0.19	25	2570	350		
49	25	0.15	20	2769	350		
58	30	0.16	16.7	2942	350		
53	40	0.12	12.5	3238	350		
52	50	0.1	10	3488	350		
46	60	0.08	8.3	3490	350		
40	80	0.06	6.3	3490	350		
38	100	0.05	5	3490	350		
102	7.5	0.86	66.7	2544	490	NRV050	54
104	10	0.67	50	2800	490		
102	15	0.47	33.3	3205	490		
92	20	0.33	25	3528	490		
94	25	0.28	20	3800	490		
106	30	0.29	16.7	4038	490		
99	40	0.22	12.5	4445	490		
89	50	0.17	10	4788	490		
82	60	0.14	8.3	4840	490		
75	80	0.11	6.3	4840	490		
69	100	0.09	5	4840	490		
180	7.5	1.5	66.7	3325	700	NRV063	54
188	10	1.2	50	3660	700		
188	15	0.85	33.3	4190	700		
178	20	0.63	25	4611	700		
163	25	0.48	20	4967	700		
204	30	0.54	16.7	5279	700		
186	40	0.4	12.5	5810	700		
174	50	0.32	10	6259	700		
162	60	0.26	8.3	6270	700		
138	80	0.19	6.3	6270	700		
131	100	0.16	5	6270	700		

■ NRV...(n1=500)

M2n [Nm]	i	P1n [Kw]	n2 [1/min]	Fr2 [N]	Fr1 [N]		page
253	7.5	2.1	66.7	3925	980	NRV075	54
266	10	1.7	50	4320	980		
268	15	1.2	33.3	4945	980		
281	20	0.98	25	5443	980		
251	25	0.73	20	5863	980		
299	30	0.77	16.7	6231	980		
279	40	0.58	12.5	6858	980		
248	50	0.44	10	7380	980		
234	60	0.37	8.3	7380	980		
220	80	0.29	6.3	7380	980		
206	100	0.24	5	7380	980		
406	7.5	3.3	66.7	4343	1270	NRV090	54
433	10	2.7	50	4780	1270		
488	15	2.1	33.3	5472	1270		
477	20	1.6	25	6022	1270		
430	25	1.2	20	6487	1270		
568	30	1.4	16.7	6894	1270		
486	40	0.95	12.5	7588	1270		
451	50	0.75	10	8174	1270		
407	60	0.59	8.3	8180	1270		
368	80	0.45	6.3	8180	1270		
328	100	0.35	5	8180	1270		
788	7.5	6.4	66.7	5488	1700	NRV110	54
844	10	5.2	50	6040	1700		
906	15	3.9	33.3	6914	1700		
856	20	2.8	25	7610	1700		
894	25	2.4	20	8198	1700		
988	30	2.4	16.7	8711	1700		
909	40	1.7	12.5	9588	1700		
882	50	1.4	10	10320	1700		
810	60	1.1	8.3	10320	1700		
668	80	0.76	6.3	10320	1700		
609	100	0.59	5	10320	1700		
1071	7.5	8.6	66.7	7178	2100	NRV130	54
1153	10	7.1	50	7900	2100		
1293	15	5.5	33.3	9043	2100		
1222	20	4.0	25	9953	2100		
1192	25	3.2	20	10722	2100		
1378	30	3.3	16.7	11394	2100		
1284	40	2.4	12.5	12540	2100		
1216	50	1.9	10	13500	2100		
1105	60	1.5	8.3	13500	2100		
967	80	1.1	6.3	13500	2100		
877	100	0.85	5	13500	2100		



■ NRV-NMRV ...(n1=1400)

M2n [Nm]	i	P1n [Kw]	n2 [1/min]	Fr2 [N]	Fr1 [N]		page
73	300	0.08	4.7	3490	210	NRV030/040	62
67	400	0.06	3.5	3490	210		
59	500	0.04	2.8	3490	210		
63	600	0.04	2.3	3490	210		
68	750	0.04	1.9	3490	210		
59	900	0.03	1.6	3490	210		
48	1200	0.02	1.2	3490	210		
57	1500	0.02	0.9	3490	210		
60	1800	0.02	0.8	3490	210		
36	2400	0.01	0.58	3490	210		
45	3200	0.01	0.4	3490	210		
33	4000	0.01	0.4	3490	210		
29	5000	0.01	0.28	3490	210		
140	300	0.15	4.7	4840	210		
115	400	0.1	3.5	4840	210		
120	500	0.09	2.8	4840	210		
130	600	0.08	2.3	4840	210		
123	750	0.07	1.9	4840	210		
118	900	0.06	1.6	4840	210		
96	1200	0.04	1.2	4840	210		
111	1500	0.04	0.93	4840	210		
122	1800	0.04	0.78	4840	210		
110	2400	0.03	0.6	4840	210		
80	3000	0.02	0.5	4840	210		
82	4000	0.02	0.35	4840	210		
82	4800	0.02	0.29	4840	210		
234	300	0.24	4.7	6270	210	NRV030/063	62
228	400	0.19	3.5	6270	210		
210	500	0.15	2.8	6270	210		
216	600	0.13	2.3	6270	210		
199	750	0.11	1.9	6270	210		
188	900	0.09	1.6	6270	210		
197	1200	0.08	1.2	6270	210		
773	1500	0.06	0.93	6270	210		
159	1800	0.05	0.78	6270	210		
189	2400	0.05	0.58	6270	210		
171	3000	0.04	0.47	6270	210		
147	4000	0.03	0.35	6270	210		
109	5000	0.02	0.28	6270	210		
373	300	0.36	4.7	7380	350		
346	400	0.27	3.5	7380	350		
315	500	0.21	2.8	7380	350		
355	600	0.19	2.3	7380	350		
330	750	0.16	1.9	7380	350		
326	900	0.14	1.6	7380	350		



■ NRV-NMRV ...(n1=1400)

M2n [Nm]	i	P1n [Kw]	n2 [1/min]	Fr2 [N]	Fr1 [N]		page
315	1200	0.11	1.2	7380	350	NRV040/075	62
339	1500	0.1	0.93	7380	350		
331	1800	0.09	0.78	7380	350		
311	2400	0.07	0.58	7380	350		
254	3000	0.05	0.47	7380	350		
240	4000	0.04	0.35	7380	350		
205	5000	0.03	0.28	7380	350		
614	300	0.56	4.7	8180	350		
587	400	0.43	3.5	8180	350		
545	500	0.34	2.8	8180	350		
585	600	0.3	2.3	8180	350		
509	750	0.23	1.9	8180	350		
465	900	0.19	1.6	8180	350		
514	1200	0.17	1.2	8180	350		
503	1500	0.14	0.93	8180	350		
431	1800	0.11	0.78	8180	350		
543	2400	0.11	0.58	8180	350		
439	3000	0.08	0.47	8180	350		
460	4000	0.08	0.35	8180	350		
410	5000	0.06	0.28	8180	350		
1229	300	1.1	4.7	10320	490	NRV050/100	62
1164	400	0.79	3.5	10320	490		
1248	500	0.61	2.8	10320	490		
1096	600	0.55	2.3	10320	490		
1108	750	0.49	1.9	10320	490		
1078	900	0.43	1.6	10320	490		
962	1200	0.31	1.2	10320	490		
1109	1500	0.3	0.93	10320	490		
1051	1800	0.26	0.78	10320	490		
1001	2400	0.19	0.58	10320	490		
914	3000	0.15	0.47	10320	490		
819	4000	0.13	0.35	10320	490		
746	5000	0.1	0.28	10320	490		
1737	300	1.5	4.7	13500	700		
1621	400	1.1	3.5	13500	700		
1496	500	0.86	2.8	13500	700		
1578	600	0.76	2.3	13500	700		
1559	750	0.66	1.9	13500	700		
1558	900	0.58	1.6	13500	700		
1403	1200	0.43	1.2	13500	700		
1522	1500	0.39	0.93	13500	700		
1500	1800	0.35	0.78	13500	700		
1358	2400	0.25	0.58	13500	700		
1300	3000	0.2	0.47	13500	700		
1146	4000	0.15	0.35	13500	700		
938	5000	0.11	0.28	13500	700		



■ NRV-NMRV ...(n1=1400)

P1n [Kw]	n2 [1/min]	M2n [Nm]	i			page
0.18	117-22.5	9-18	12-61.5	UDL0.18-NMRV040	6324	47&63
	88-17	12-23	16-82			
	58.7-11.3	17-32	24-123			
	44-8.5	22-40	32-164			
	35.2-6.8	27-47	40-205			
	29.3-5.7	30-51	48-246			
	22-4.3	37-62	64-328			
	17.6-3.4	43-60	80-410			
	22-4.3	38-63	64-328	UDL0.18-NMRV050	6324	48&63
	17.6-3.4	44-73	80-410			
	14.7-2.8	50-80	96-492			
	11-2.1	59-82	128-656			
	8.8-1.7	66-79	160-820			
0.37	133-26.7	19-36	10.5-52.5	UDL0.37-NMRV050	7124	48&63
	100-20	25-47	14-70			
	66.7-13.3	36-65	21-105			
	50-10	46-82	28-140			
	40-8	55-97	35-175			
	33.3-6.7	61-107	42-210			
	25-5	76-124	56-280			
	20-4	89-120	70-350			
	25-5	79-134	56-280	UDL0.37-NMRV063	7124	49&63
	20-4	92-155	70-350			
	16.7-3.3	104-173	84-420			
	12.5-2.5	125-173	112-560			
	10-2	139-150	140-700			
0.55	133-26.7	26-49	10.5-52.5	UDL0.55-NMRV063	8014	49&63
	100-20	34-63	14-70			
	66.7-13.3	48-88	21-105			
	50-10	62-112	28-140			
	40-8	75-133	35-175			
	33.3-6.7	81-146	42-210			
	25-5	105-179	56-280			
	20-4	123-207	70-350			
	20-4	129-216	70-350	UDL0.55-NMRV075	8014	50&63
	16.7-3.3	146-242	84-420			
	12.5-2.5	176-250	112-560			
	12.5-2.5	189-309	112-560			
	10-2	218-350	140-700			
0.75	133-26.7	39-73	10.5-52.5	UDL0.75-NMRV063	8024	49&63
	100-20	51-94	14-70			
	66.7-13.3	72-132	21-105			
	50-10	92-168	28-140			
	40-8	112-199	35-175			
	33.3-6.7	126-219	42-210			
	25-5	156-232	56-280			
	20-4	185-310	70-350			
	20-4	192-320	70-350			
	16.7-3.3	219-300	84-420			
	16.7-3.3	230-389	84-420			
	12.5-2.5	265-428	112-560	UDL0.75-NMRV090	8024	61&63
	10-2	303-410	140-700			
	12.5-2.5	302-503	112-560			
	10-2	348-575	140-700	UDL0.75-NMRV110	8024	52&63

■ NRV-NMRV ...(n1=1400)

P1n [Kw]	n2 [1/min]	M2n [Nm]	i			page
1.1	133-26.7	59-111	105-52.5	UD1.1-NMRV075	90S4	50&63
	100-20	77-144	14-70			
	66.7-13.3	110-203	21-105			
	50-10	142-258	28-140			
	40-8	172-308	35-175			
	33.3-6.7	195-340	42-210			
	25-5	245-360	56-280			
	100-20	78-146	14-70			
	66.7-13.3	113-208	21-105			
	50-10	146-266	28-140			
	40-8	177-320	35-175			
	33.3-6.7	202-356	42-210			
	25-5	256-442	56-280			
	20-4	304-517	70-350			
	20-4	320-550	70-350	UD1.1-NMRV110	90S4	52&63
	16.7-3.3	368-625	84-420			
	12.5-2.5	455-754	112-560			
	10-2	522-710	140-700			
16.7-3.3	373-623	84-420	UD1.1-NMRV130	90S4	53&63	
12.5-2.5	460-749	112-560				
10-2	531-868	140-700				
1.5	133-26.7	78-148	10.5-52.5	UD1.5-NMRV075	90L4	50&63
	100-20	102-192	14-70			
	66.7-13.3	147-270	21-105			
	50-10	190-344	28-140			
	40-8	229-330	35-175			
	33.3-6.7	260-390	42-210			
	25-5	327-360	56-280			
	133-26.7	77-150	10.5-52.5			
	100-20	104-195	14-70			
	66.7-13.3	150-277	21-105			
	50-10	194-355	28-140			
	40-8	236-427	35-175			
	33.3-6.7	270-474	42-210			
	25-5	341-589	56-280			
	20-4	406-560	70-350			
	20-4	426-733	70-350	UD1.5-NMRV110	90L4	52&63
	16.7-3.3	490-833	84-420			
	16.7-3.3	498-831	84-420	UD1.5-NMRV130	90L4	53&63
12.5-2.5	614-999	112-560				
10-2	696-1100	140-700				

■ NRV-NMRV ...(n1=1400)

P _{1n} [Kw]	n ₂ [1/min]	M _{2n} [Nm]	i			page
2.2	133-26.7	120-226	10.5-52.5	UD2.2-NMRV110	100LA4	52&63
	100-20	157-294	14-70			
	66.7-13.3	228-418	21-105			
	50-10	298-549	28-140			
	40-8	364-664	35-175			
	33.3-6.7	413-717	42-210			
	25-5	533-931	56-280	UD2.2-NMRV130	100LA4	53&63
	25-5	542-932	56-280			
	20-4	648-1097	70-350			
	16.7-3.3	746-1246	84-420			
	12.5-2.5	921-1499	112-560			
	10-2	1040-1690	140-700			
3.0	133-26.7	160-302	10.5-52.5	UD3-NMRV110	100LB4	52&63
	100-20	210-392	14-70			
	66.7-13.3	304-558	21-105			
	50-10	398-732	28-140			
	40-8	485-885	35-175			
	33.3-6.7	547-956	42-210			
	25-5	711-1030	56-280	UD3-NMRV130	100LB4	53&63
	133-26.7	160-301	10.5-52.5			
	100-20	211-395	14-70			
	66.7-13.3	307-563	21-105			
	50-10	402-733	28-140			
	40-8	490-885	35-175			
33.3-6.7	562-973	42-210	UD4-NMRV110	124M4	52&63	
25-5	720-1242	56-280				
20-4	864-1463	70-350				
133-26.7	243-402	10.5-52.5				
100-20	279-523	14-70				
66.7-13.3	405-744	21-105				
50-10	530-975	28-140	UD4-NMRV130	124M4	53&63	
40-8	647-1020	35-175				
133-26.7	214-401	10.5-52.5				
100-20	281-527	14-70				
66.7-13.3	410-751	21-105				
50-10	536-978	28-140				
40-8	653-1180	35-175	UD4-NMRV130	124M4	53&63	
33.3-6.7	749-1298	42-210				
25-5	960-1650	56-280				

■ WORM GEAR UNITS NMRV025

Weight without motor ≈ 0.7kg

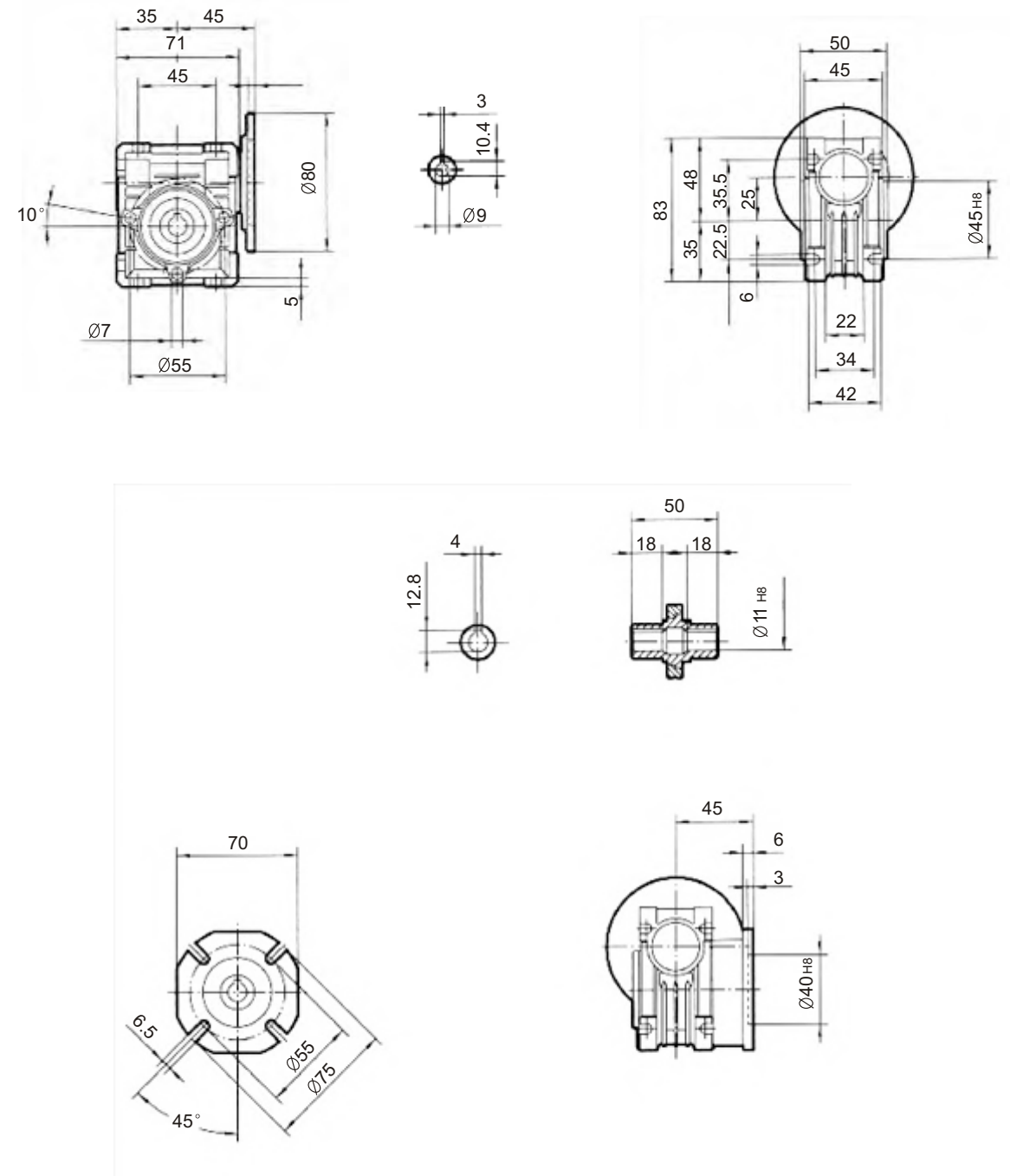

■ NMRV050

Weight without motor ≈ 3.5kg

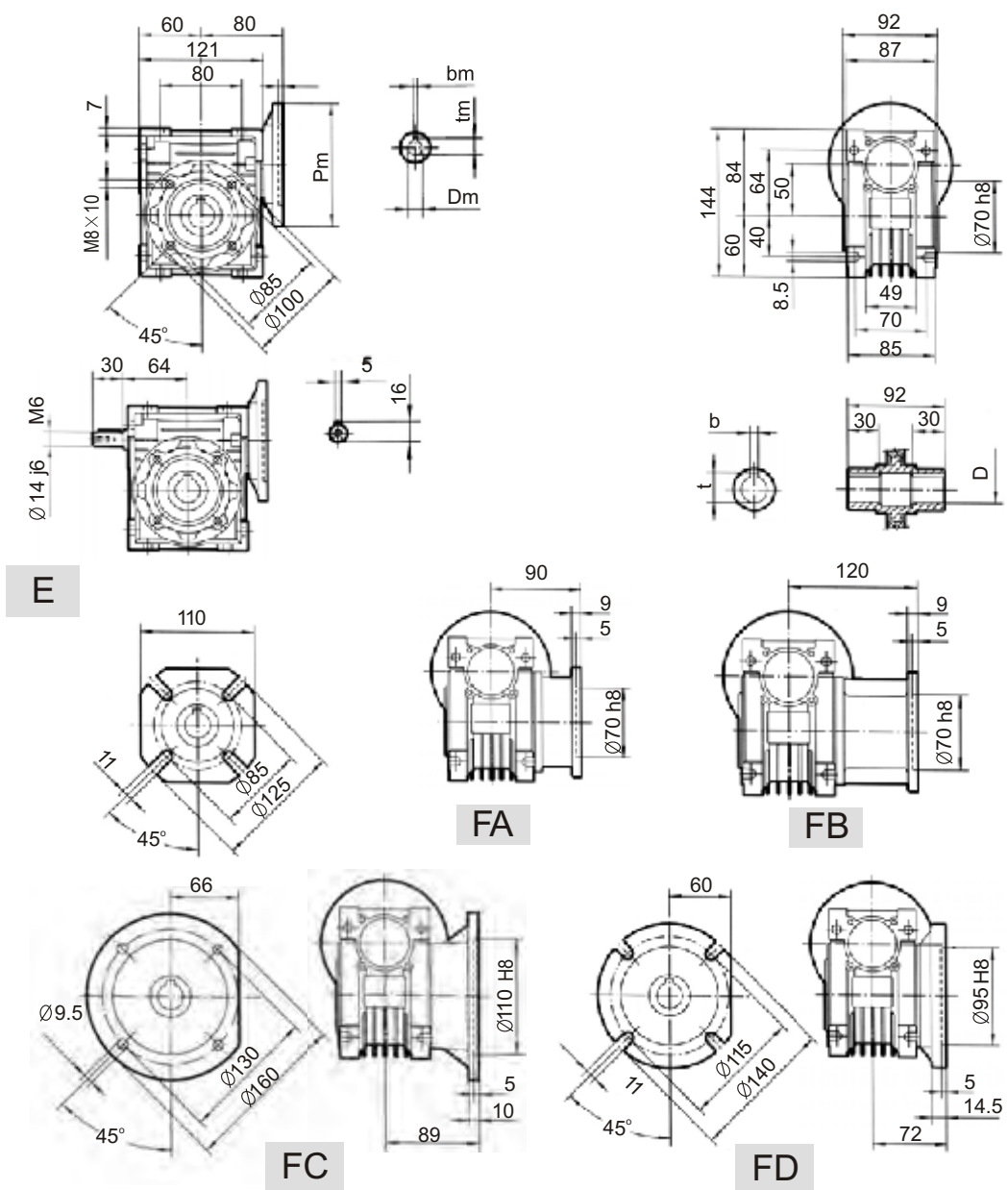

PAM IEC	PM	DM E8	bm	tm	DH8	b	t
80B5	200	19	6	21.8	25	8	28.3
71B5	160	14	5	16.3	24*	8*	27.3*
63B5	140	11	4	12.8	*Only on request		
80B14	120	19	6	21.8			
71B14	105	14	5	16.3			

■ NMRV063

Weight without motor ≈ 6.2kg

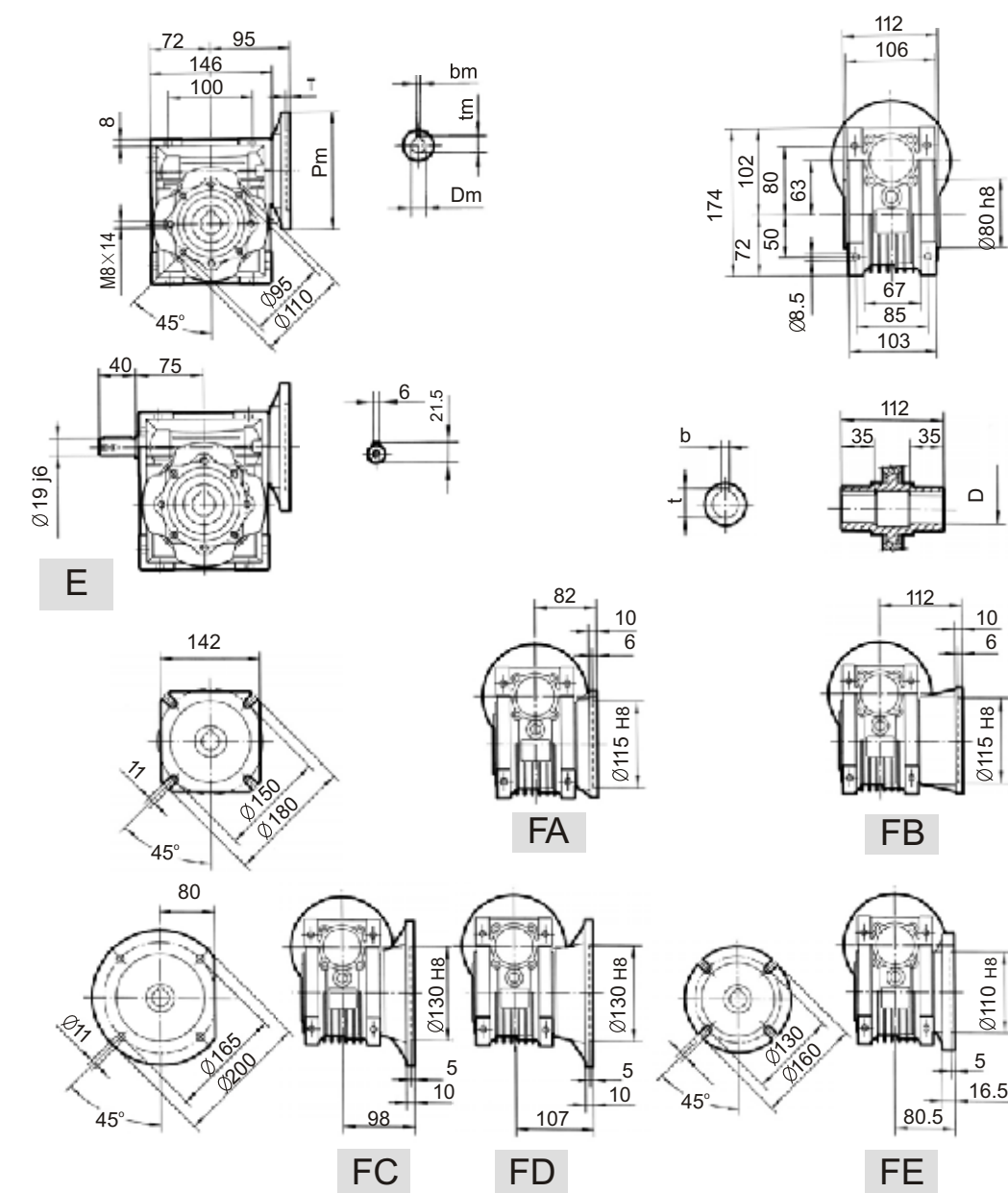

PAM IEC	PM	DM E8	bm	tm	DH8	b	t
90B5	200	24	8	27.3	25	8	28.3
80B5	200	19	6	21.8	28*	8*	31.3*
71B5	160	14	5	16.3	*Only on request		
90B14	140	24	8	27.3			
80B14	120	19	6	21.8			
71B14	105	14	5	16.3			

■ NMRV075

Weight without motor ≈ 9

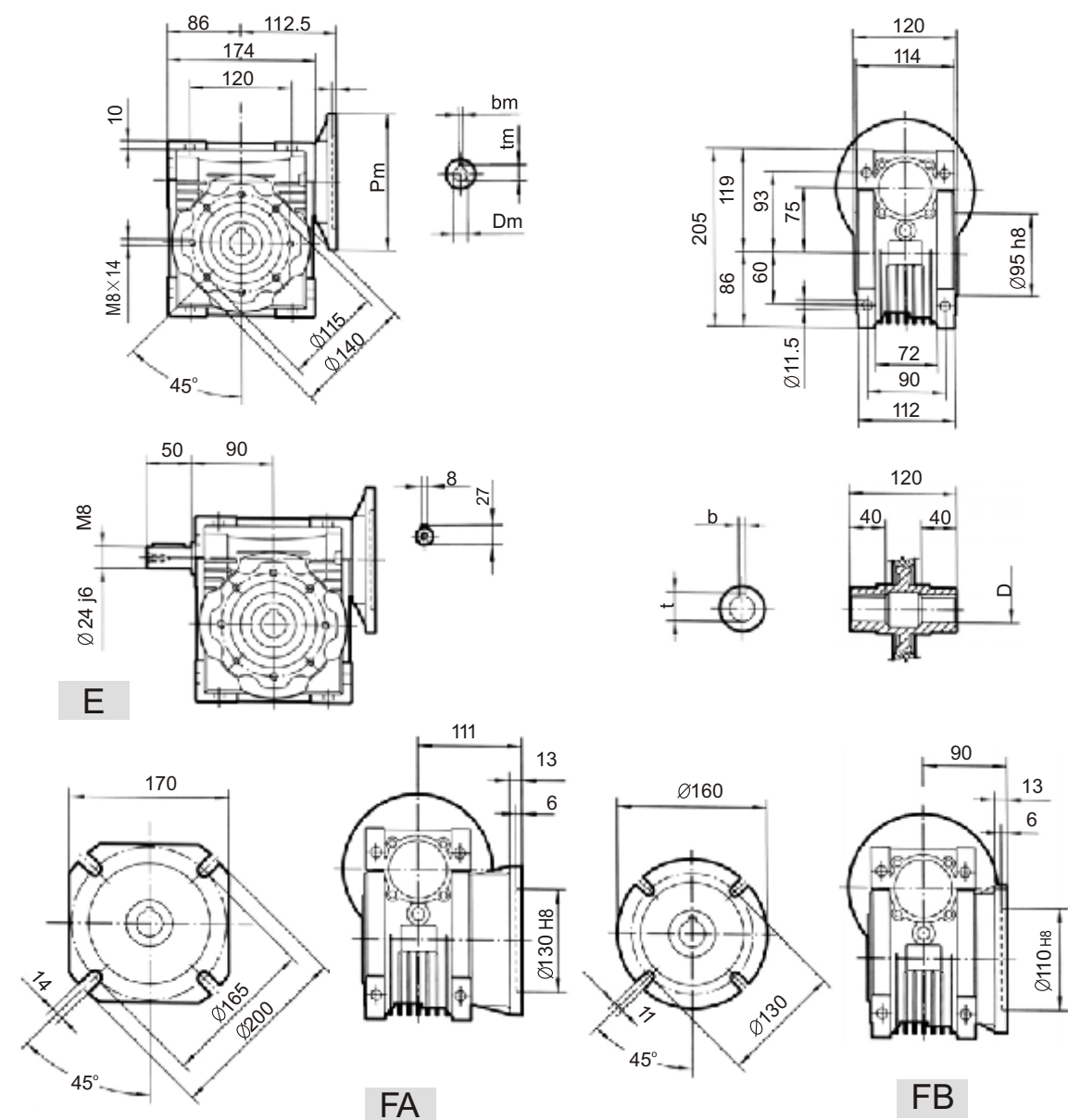

■ NMRV090

Weight without motor ≈ 13kg

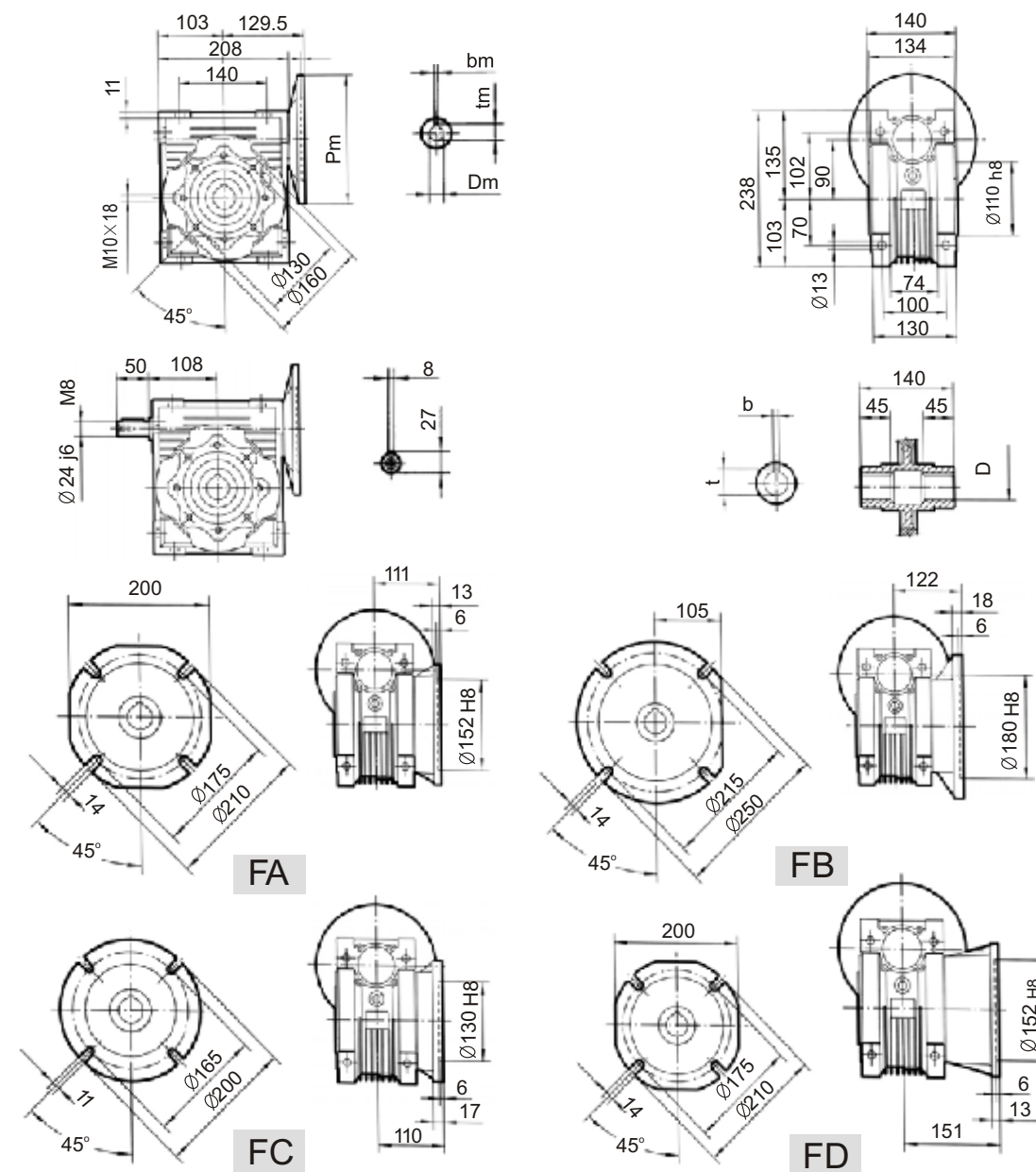

PAM IEC	Pm	Dm E8	bm	tm	DH8	b	t
100/112B5	250	28	8	31.3	28	8	31.3
90B5	200	24	8	27.3	35*	10*	38.3*
80B5	200	19	6	21.8	*Only on request		
71B5	160	14	5	16.3			
100/112B14	160	28	8	31.3			
90B14	140	24	8	27.3			
80B14	120	19	6	21.8			

PAM IEC	Pm	Dm E8	bm	tm	DH8	b	t
100/112B5	250	28	8	31.3	35	10	38.3
90B5	200	24	8	27.3	38*	10*	41.3*
80B5	200	19	6	21.8	*Only on request		
100/112B14	160	28	8	31.3			
90B14	140	24	8	27.3			
80B14	120	19	6	21.8			

■ NMRV110

Weight without motor ≈ 35kg

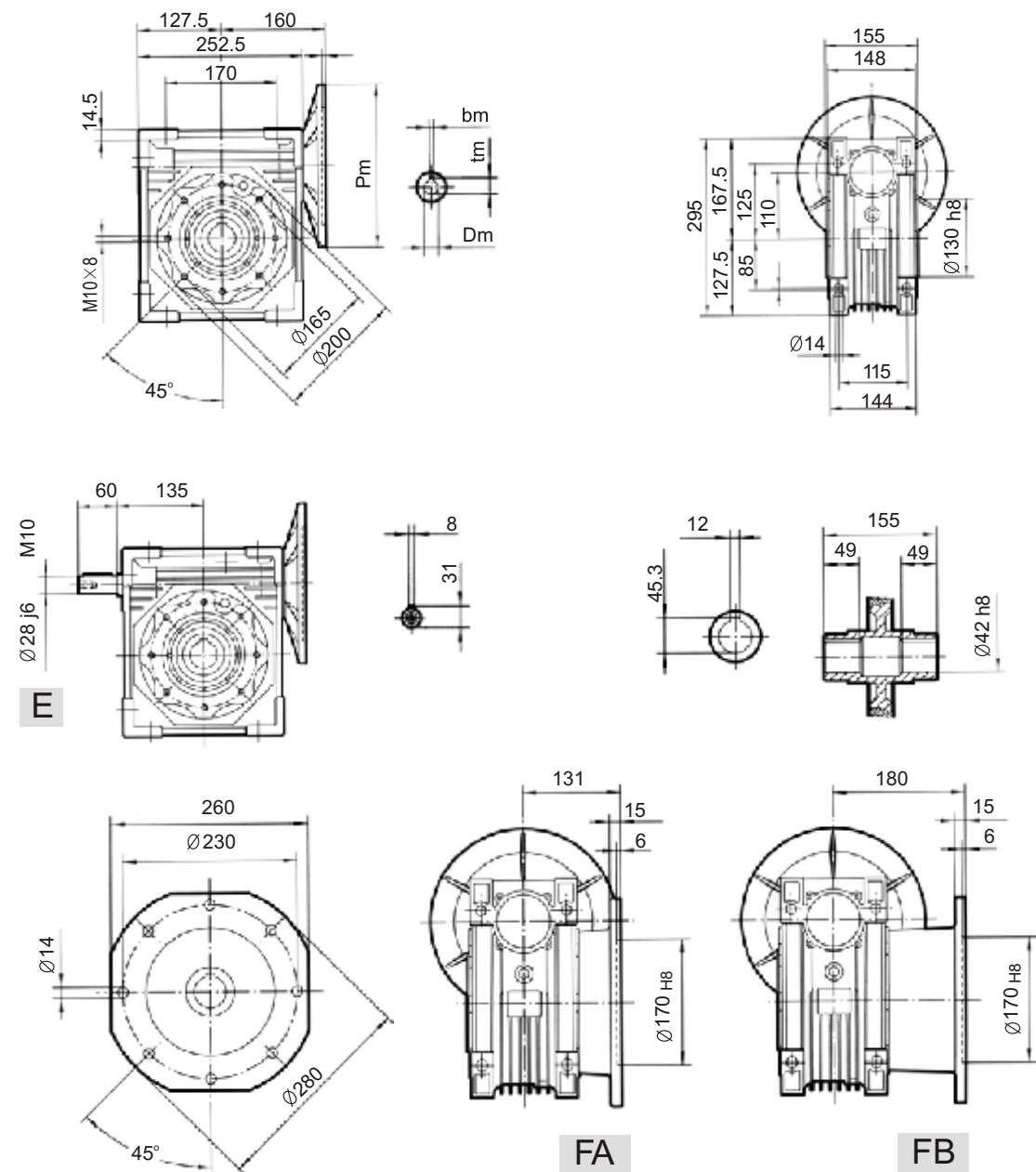

PAM IEC	P _m	D _m E8	b _m	t _m
132B5	300	38	10	41.3
112B5	250	28	8	31.3
100B5	250	28	8	31.3
90B5	200	24	8	27.3
80B5	200	19	6	21.8

■ NMRV130

Weight without motor ≈ 48kg

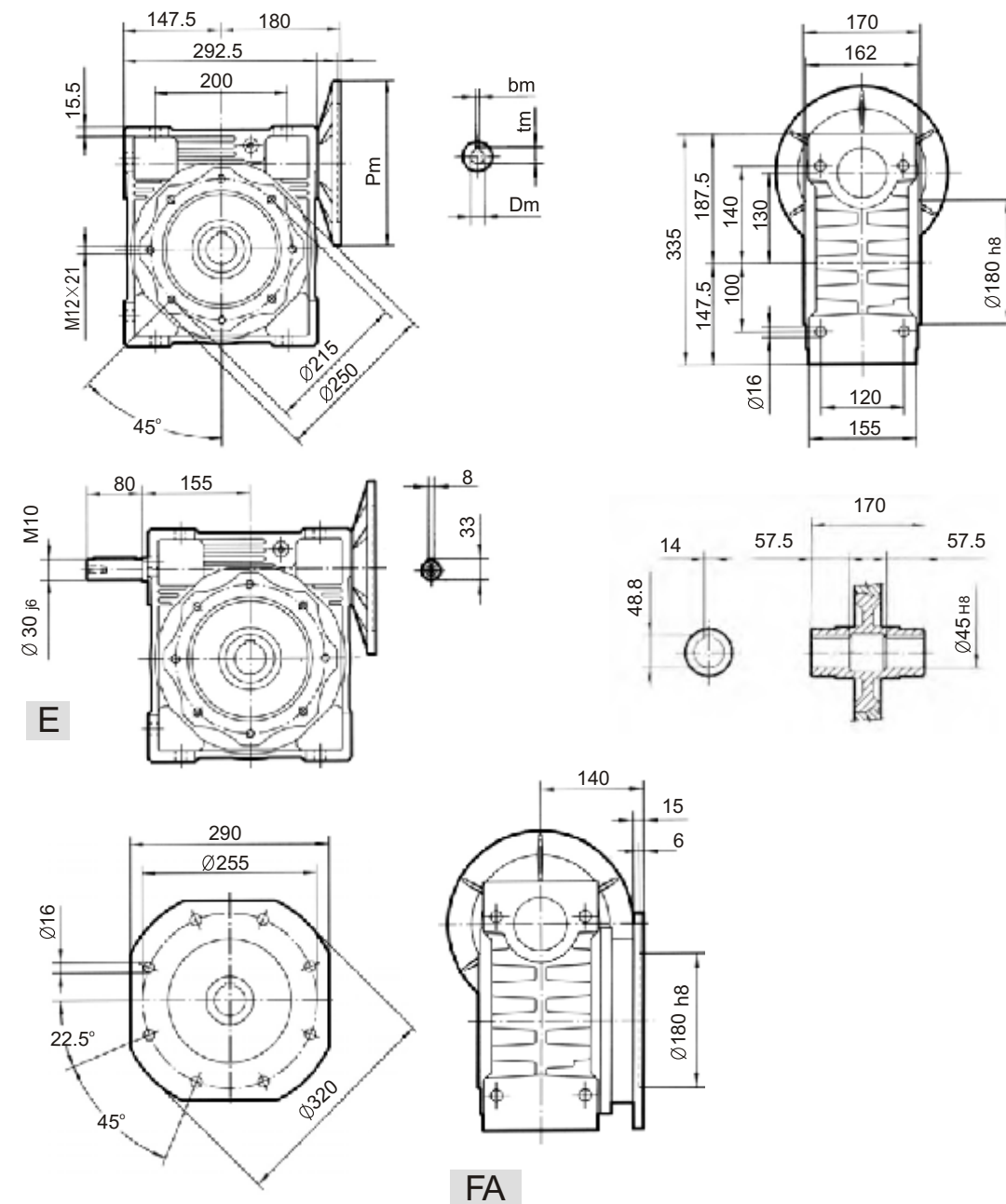

PAM IEC	P _m	D _m E8	b _m	t _m
132B5	300	38	10	41.3
112B5	250	28	8	31.3
100B5	250	28	8	31.3
90B5	200	24	8	27.3

■ NRV WORM GEAR UNITS

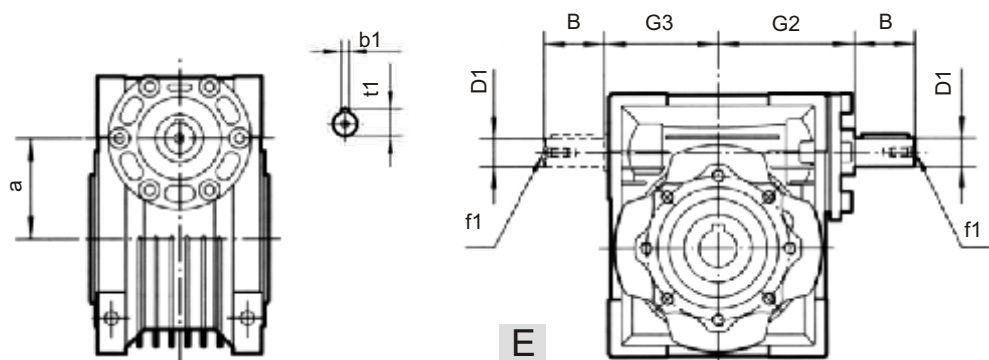

NRV	030	040	050	063	075	090	110	130
B	20	23	30	40	50	50	60	80
D1 j6	9	11	14	19	24	24	28	30
G2	51	60	74	90	105	125	142	162
G3	45	53	64	75	90	108	135	155
a	30	40	50	63	75	90	110	130
b1	3	4	5	6	8	8	8	8
f1	-	-	M6	M6	M8	M8	M10	M10
t1	10.2	12.5	16	21.5	27	27	31	33

★ For the missing dimensions, Please refer to page 46-54

■ PC-NMRV OUTLINE DIMENSION

- ★ For the dimensions of the output flanges, Please refer to page 46-54
- ★ For the dimensions of the hollow Shaft ,Please refer to page 46-54
- ★ For the dimensions of the double extension Worm, Please refer to page 65

■ PC063-NMRV040

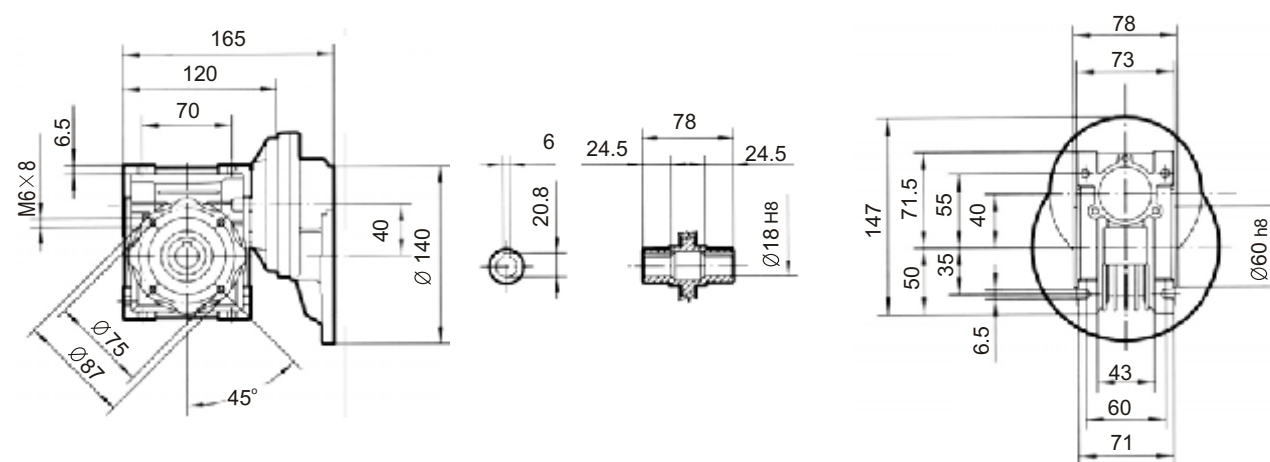

■ PC063-NMRV050

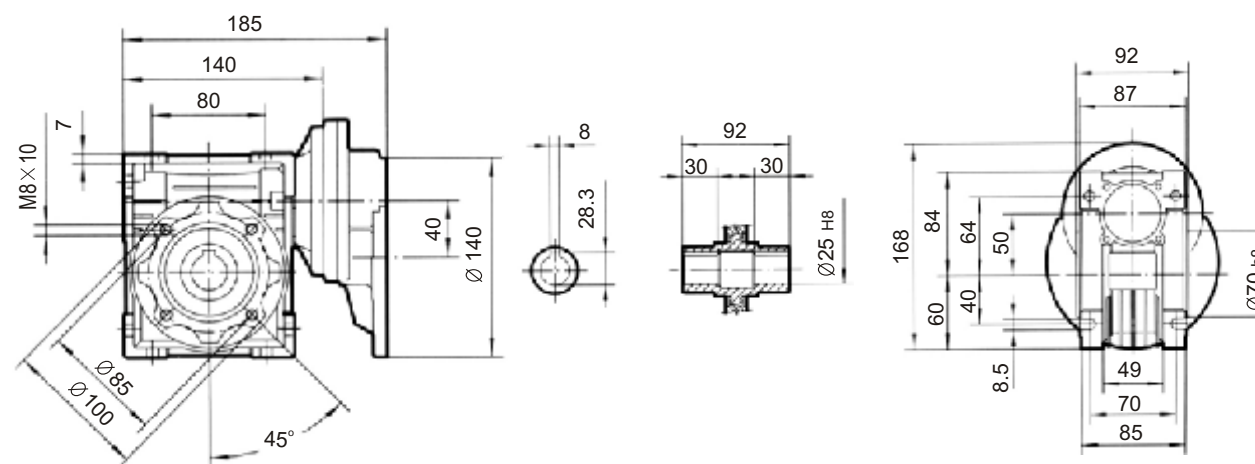

■ PC063-NMRV063

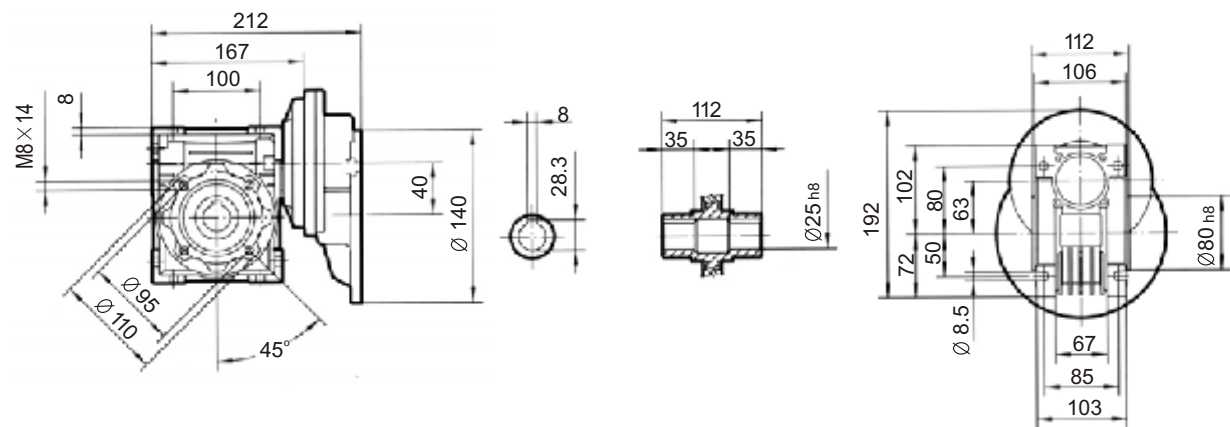

■ PC071-NMRV075

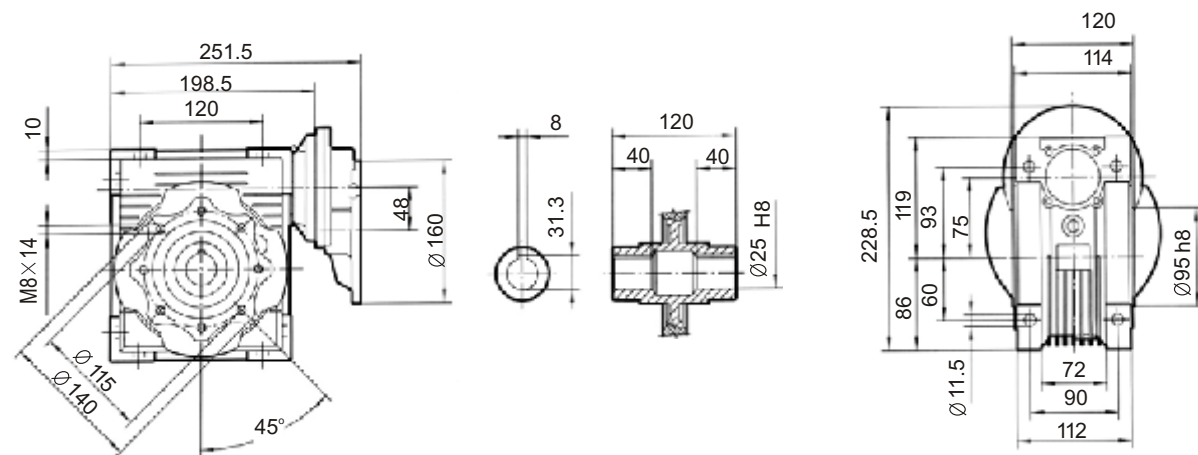

■ PC071-NMRV050

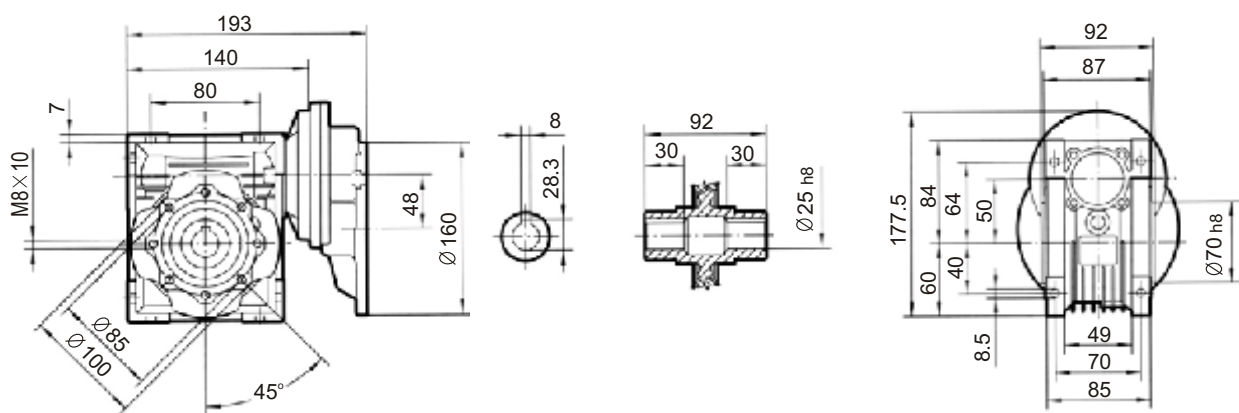

■ PC071-NMRV090

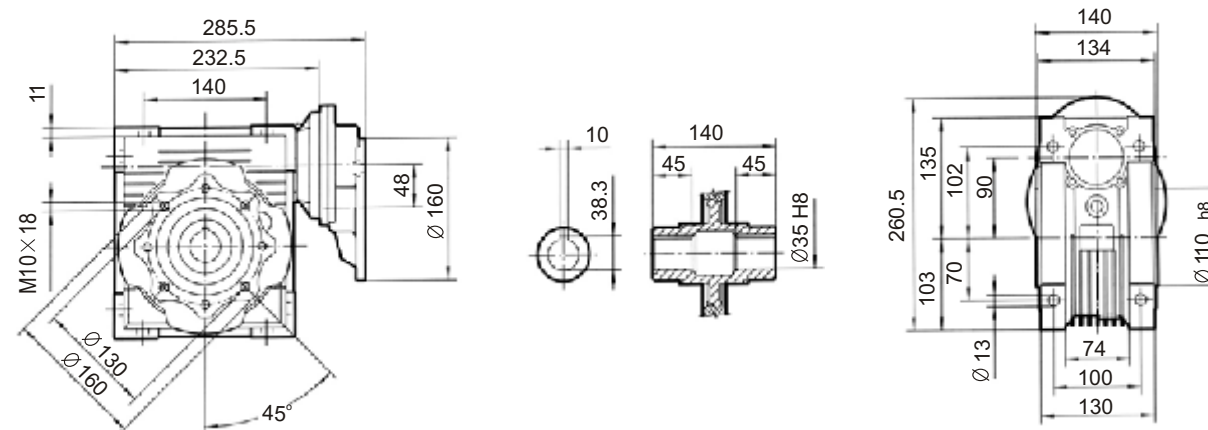

■ PC071-NMRV063

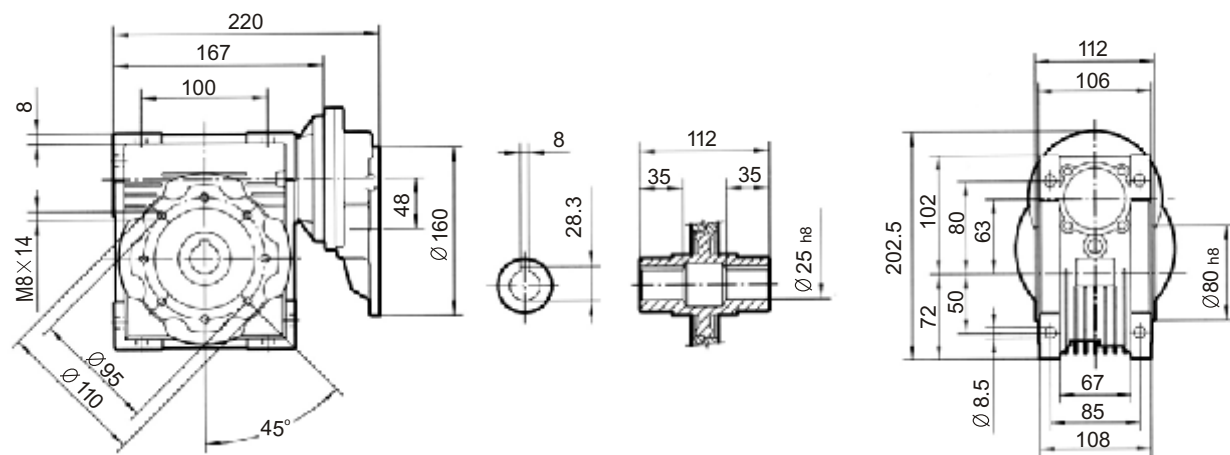

■ PC080-NMRV075

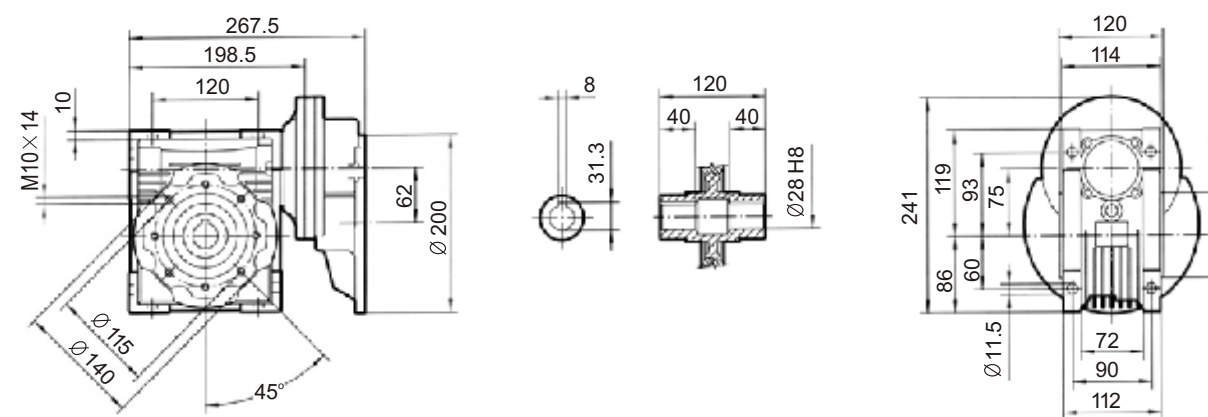

■ PC080-NMRV090

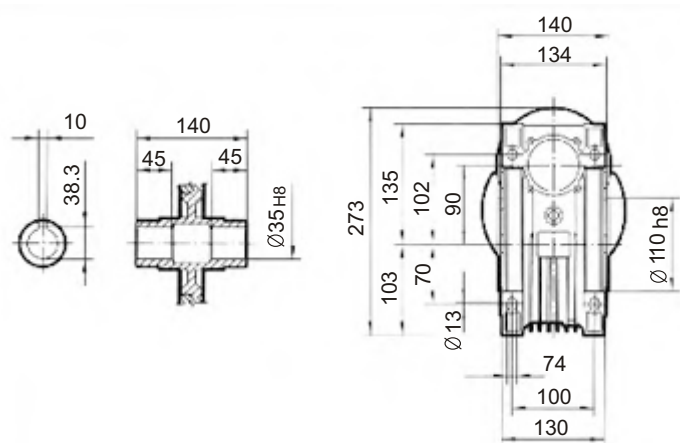
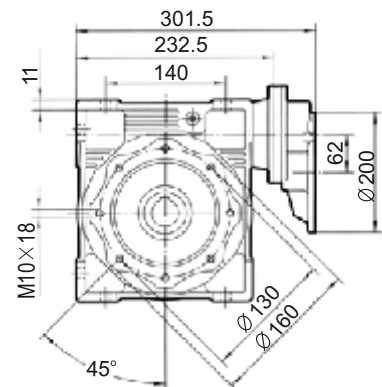

■ PC080-NMRV110

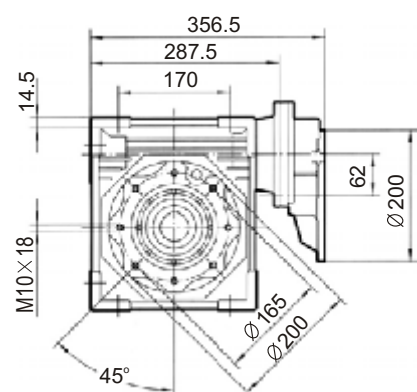

■ PC090-NMRV110

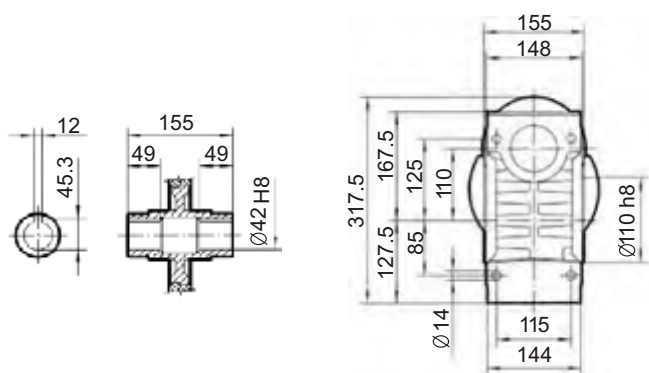

■ PC080-NMRV130

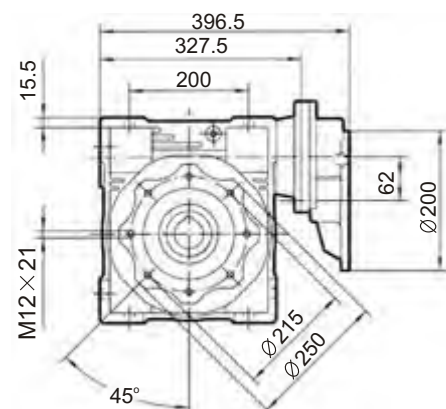

■ PC090-NMRV130

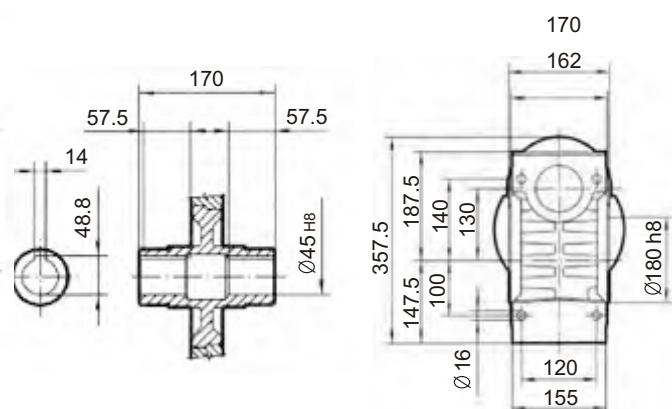

■ NMRV/NMRV OUTLINE DIMENSION

- ★ For the dimensions of the output flanges, Please refer to page 46-54
- ★ For the dimensions of the hollow shaft, Please refer to page 46-54
- ★ For the dimensions of the double extension worm. Please refer to page 65

■ NMRV025/030

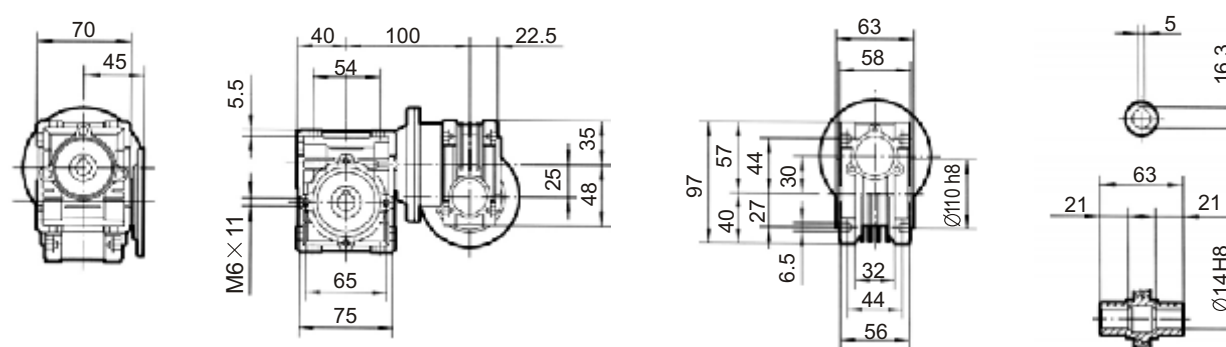

■ NMRV025/040

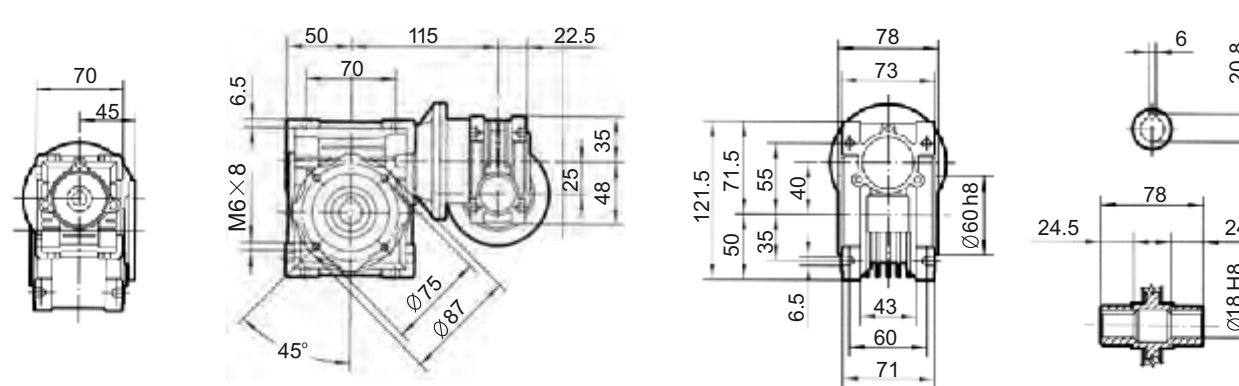

■ NMRV030/040

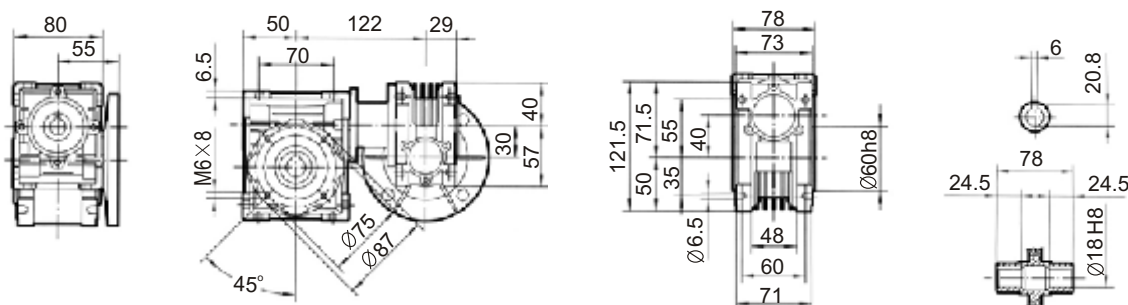

■ NMRV040/075

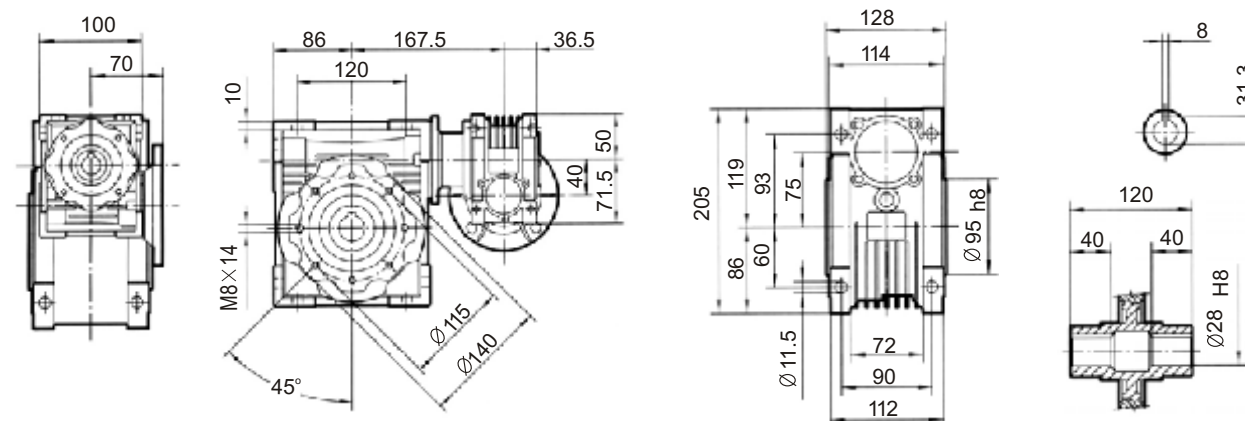

■ NMRV030/050

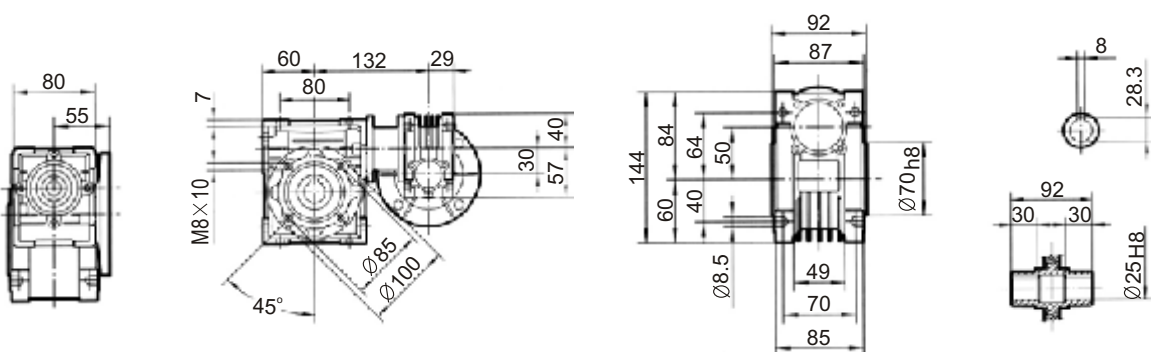

■ NMRV040/090

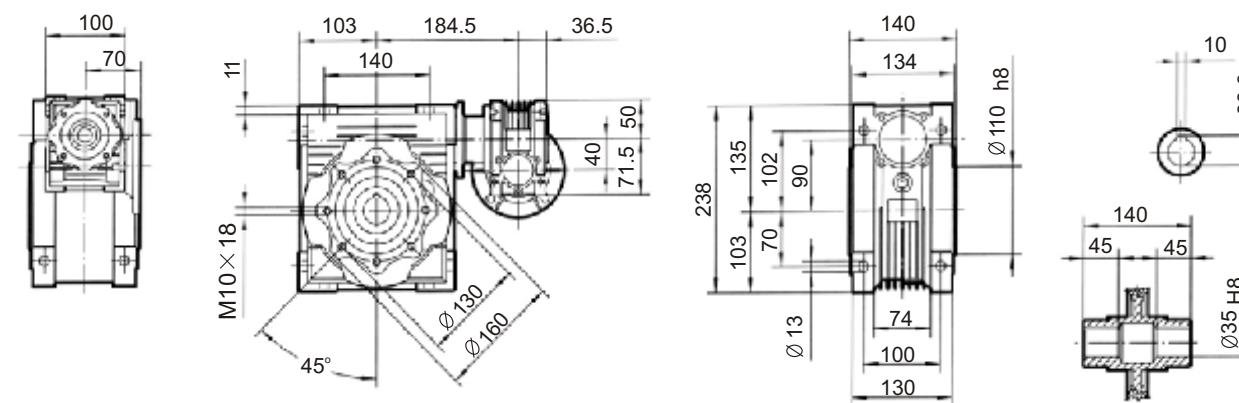

■ NMRV030/063

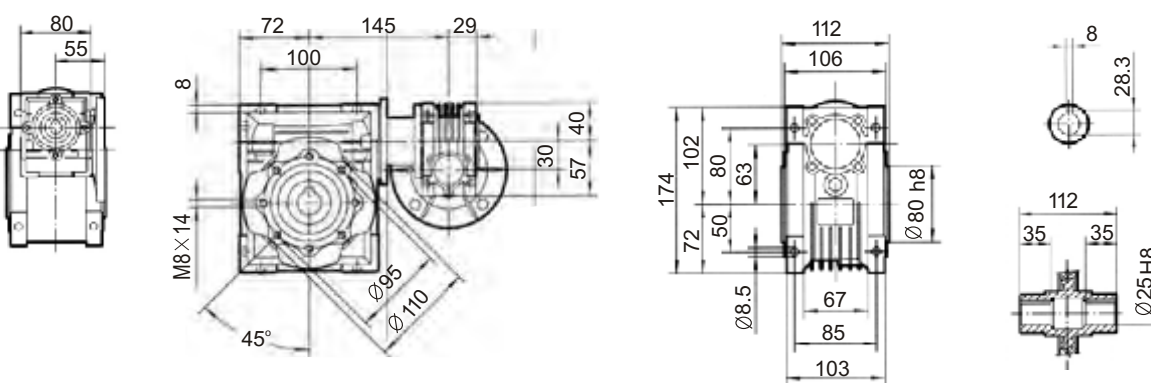

■ NMRV050/110

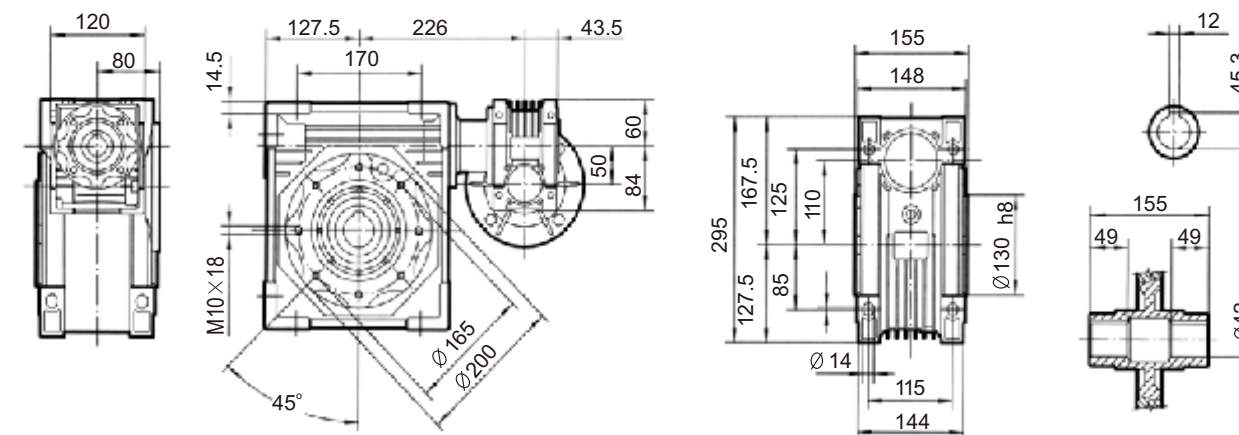

■ NMRV063/130

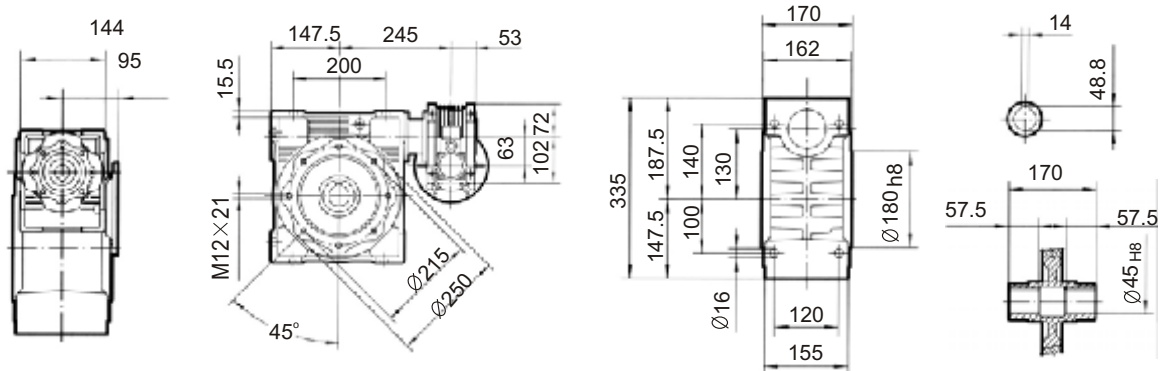

■ NRV-NMRV COMBINATION WORM GEAR UNITS

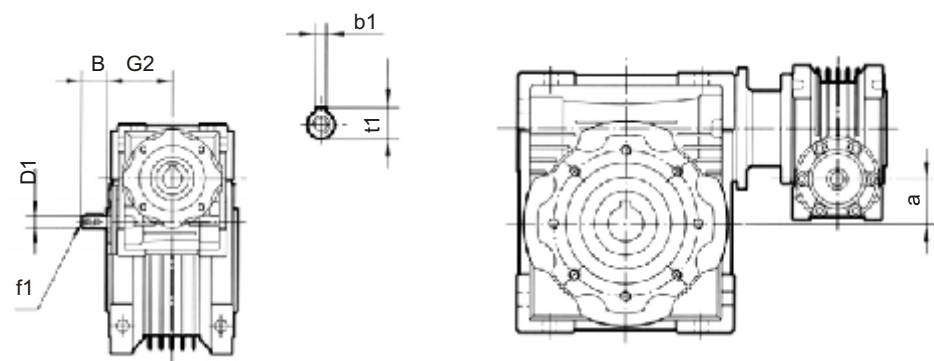

NRV-nmrv	030/040	030/050	030/063	040/070	040/090	050/110	063/30
B	20	20	20	23	23	30	40
D1 j6	9	9	9	11	11	14	19
G2	51	51	51	60	60	74	90
a	10	20	33	35	50	60	67
b1	3	3	3	4	4	5	6
f1	-	-	-	-	-	M6	M6
t1	10.2	10.2	10.2	12.5	12.5	16	21.5

■ UDL-NMRV COMBINATION OF SPEED VARITOR AND WORM GEAR UNITS

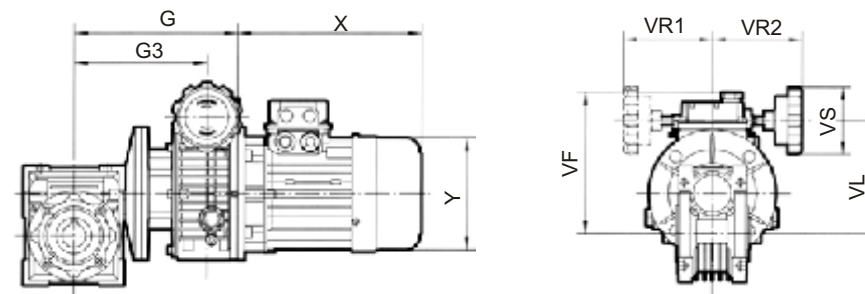

Model	G	G3	VF	VL	VS	VR	VR1	BaseN0.4 n1=1400r/min	X	Y
UDL0.18-NMRV040	183	135	151	118	85	110	110	63	200	120
UDL0.18-NMRV050	193	145	161	128	85	110	110			
UDL0.37-NMRV050	190	154	173	140	85	110	110	71	227	141
UDL0.37-NMRV063	205	169	186	153	85	110	110			
UDL0.55-NMRV063	234	181	203	170	110	120	120	80	268	160
UDL0.75-NMRV063	234	181	203	170	110	120	120			
UDL0.37-NMRV075	223	187	198	165	85	110	110	71	227	141
UDL0.55-NMRV075	252	198	215	182	110	120	120			
UDL0.75-NMRV075	252	198	215	182	110	120	120	80	268	160
UD1.1-NMRv075	259.5	207.5	199	177	110	150	-			
UD1.5-NMRV075	300.5	227.5	219	197	110	150	-	90L	290	195
UDL0.55-NMRV090	269	215	230	197	110	120	120	80	268	160
UDL0.75-NMRv090	269	215	230	197	110	120	120			
UD1.1-NMRV090	276.5	224.5	214	192	110	150	-	90S	265	195
UD1.5-NMRV090	317.5	244.5	234	212	110	150	-	90L	290	195
UD1.1-NMRV110	307	255	234	212	110	120	-	90S	265	195
UD1.5-NMRV110	348	275	254	232	110	150	-	90L	290	195
UD2.2-NMRV110	368	291	298	260	110	160	-	100L	320	215
UD3.0-NMRV110	368	291	298	260	110	160	-			
UD4.0-NMRV110	368	291	298	260	110	160	-	112M	340	240
UD1.5-NMRV130	368	295	274	252	110	150	-	90L	290	195
UD2.2-NMRV130	388	311	318	280	110	160	-	100L	320	215
UD3.0-NMRV130	388	311	318	280	110	160	-			
UD4.0-NMRV130	388	311	318	280	110	160	-	112M	340	240

OUTPUT SHAFTS

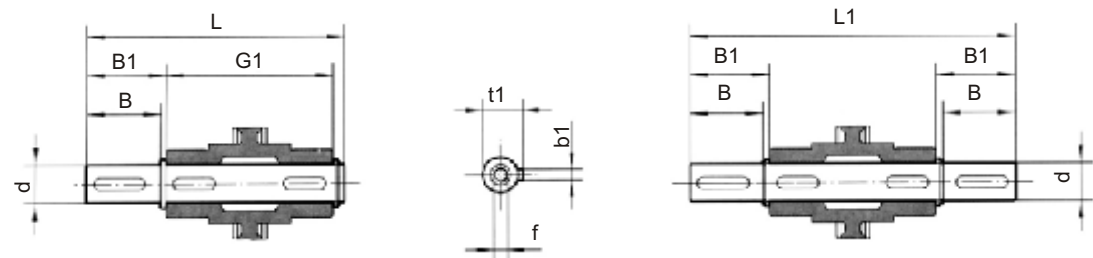

	dh6	B	B1	G1	L	L1	f	b1	t1
NMRV025	11g6	23	25.5	50	81	101	-	4	12.5
	9*	25*	30*	50	85.5*	101	-	3*	10.2*
NMRV030	14	30	32.5	63	102	128	M6	5	16
NMRV040	18	40	43	78	128	164	M5	6	20.5
NMRV050	25	50	53.5	92	153	199	M10	8	28
NMRV063	25	50	53.5	112	173	279	M10	8	28
NMRV075	28	60	63.5	120	192	247	M10	8	31
NMRV090	35	80	84.5	140	234	309	M12	10	38
NMRV110	42	80	84.5	155	249	324	M16	12	45
NMRV130	45	80	85	170	265	340	M16	14	48.5

*Only on request

TORQUE ARM

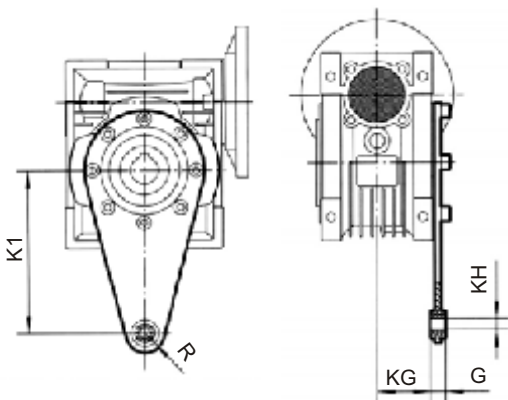

	K1	G	KG	KH	R
NMRV025	70	14	17.5	8	15
NMRV030	85	14	24	8	15
NMRV040	100	14	31.5	10	18
NMRV050	100	14	38.5	10	18
NMRV063	150	14	49	10	18
NMRV075	200	25	47.5	20	30
NMRV090	200	25	57.5	20	30
NMRV110	250	30	62	25	35
NMRV130	250	30	69	25	35

COVER

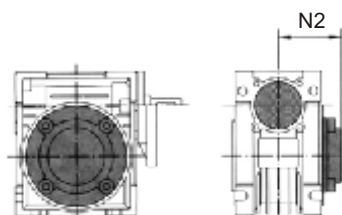

	N2	N2	N2
NMRV030	47	NMRV075	79
NMRV040	55	NMRV090	94
NMRV050	63	NMRV110	102
NMRV063	73	NMRV130	117

INSTALLATION POSITIONS DIAGRAM NMRV..OR NRV..

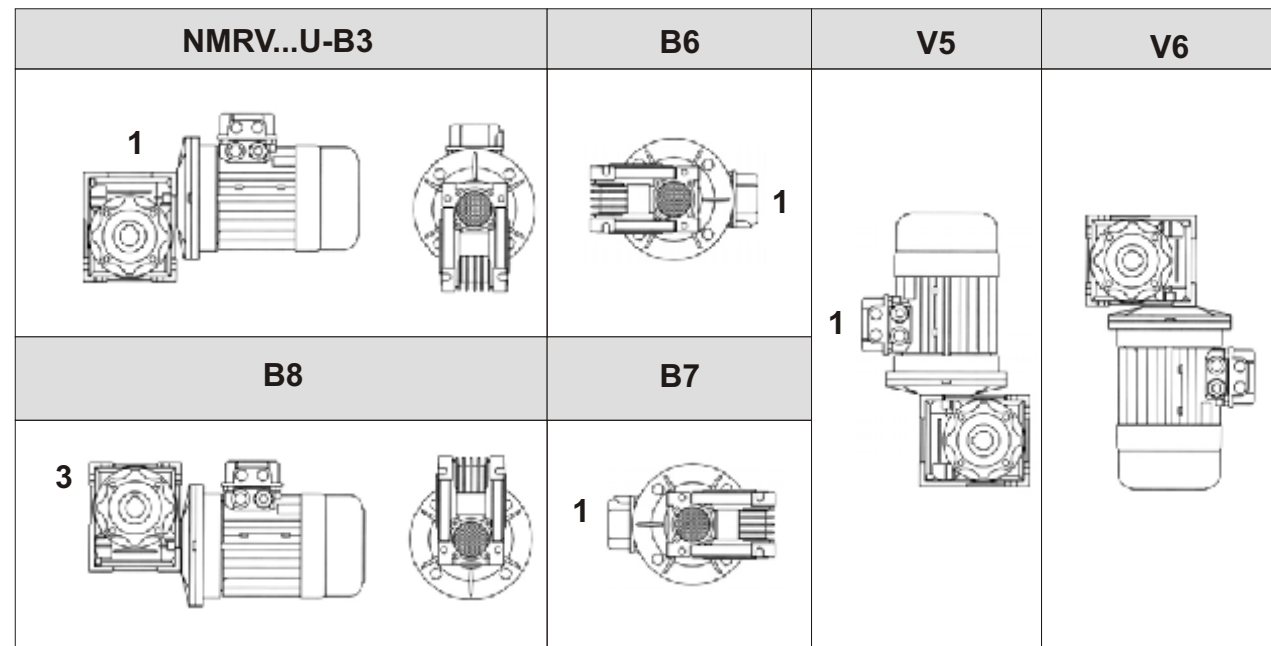

PC.. -NMRV

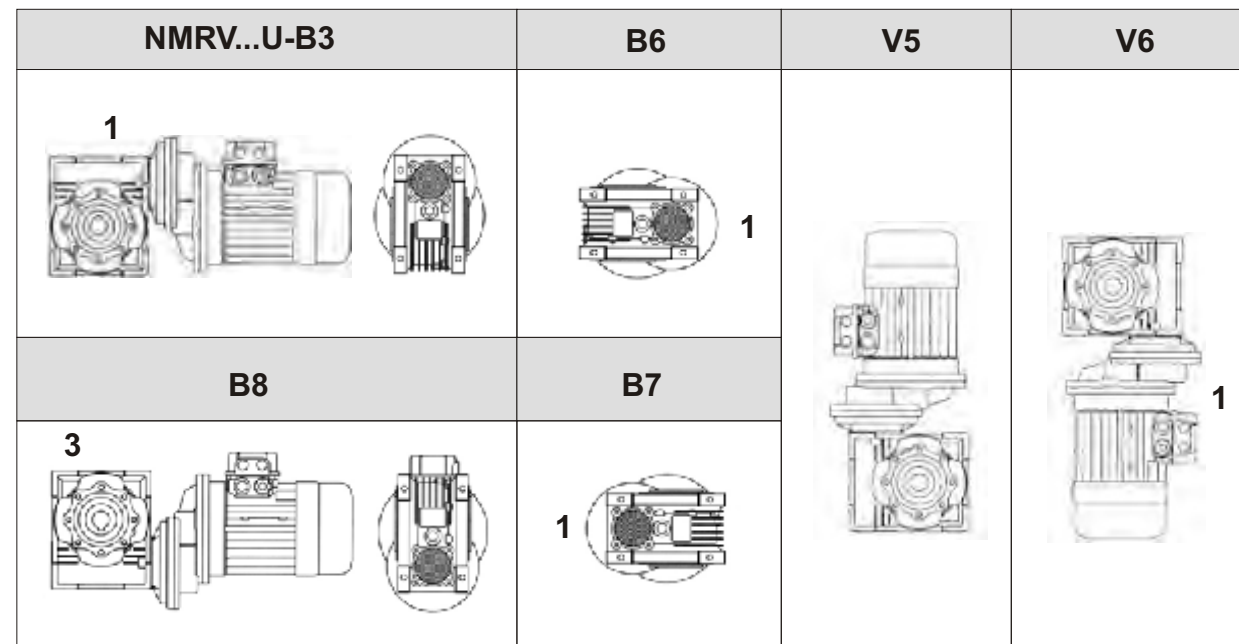

- "U" version is related to sizes from 026 to 076 and NRV030-063. For these sizes it is not necessary to specify mounting position.
- Unless specified otherwise, the standard positions are B3.
- For positions not envisaged, it is necessary to call our Technical Service.

■ NMRV.. - NMRV../ NRV.. - NMRV..

AS1	AS2	VS1	VS1
PS1	PS2	BS1	BS1

The position of 1st reducer with respect to the 2nd gear reducer depends on the versions. Unless specified at the time of order, combination groups are supplied in version BS2. The specified mounting position refers to the 1st gear reducer

■ UDL.. - NMRV..

NMRV..U-B3	B6	V5
B8	B7	

■ POSITION DIAGRAM FOR OUTPUT FLANGE

FA1,FB1,FC1,FD1,FE1	FA2,FB2,FC2,FD2,FE2

Unless specified otherwise, the reduction unit is supplied with the flange in position F..1 referred to position B3

■ POSITION DIAGRAM FOR SINGLE OUTPUT SHAFT

AS1	AS2

■ POSITION OF TERMINAL BOX

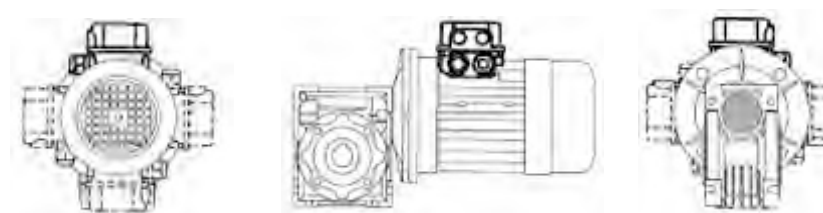

In the case of specific requirements. When ordering, specify the position of the terminal box as shown in the diagram.

■ DIRECTION OF ROTATION

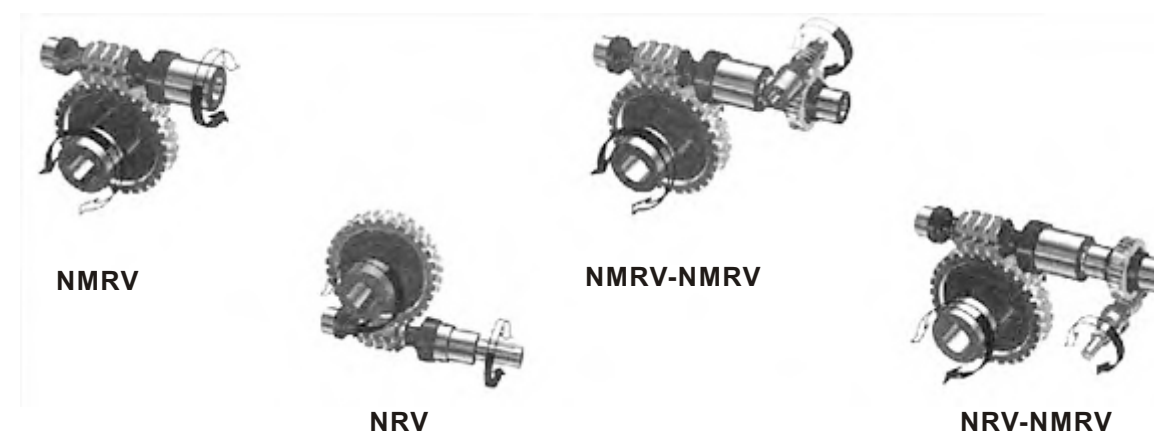

■ INSTALLATION

To install the reduction unit it is necessary to note the following recommendation:

1. Check the correct direction of rotation of the reduction unit output shaft before fitting the unit to the machine.
2. Before mount with the prime mover and device, please check the reducer's every axial diameter, aperture, key and key slot, to be sure their dimensions are not deviation, and avoid assembling too tight or too loose, unless it will influence the reducer's performance.
3. The mounting on the machine must be stable to avoid any vibration.
4. Whenever possible, protect the reduction unit against solar radiation and bad weather.
5. In the case of particularly lengthy periods of storage(4-6 months), if the oil seal is not immersed in the lubricant inside the unit, it is recommended to change it since the rubber could stick to the shaft or may even have lost the elasticity it needs function properly.
6. Painting must definitely not go over rubber parts and the holes on the breather plugs if any.
7. When connect with hollow or solid shaft, please grease the joint to avoid lock or oxidation.
8. Check the correct level of the lubricant through the indicator, if there is one.
9. Starting must take place gradually, without immediately applying the maximum load.
10. Supporting unit is required when using various of reducer matched with motor directly and the weight of motor is a little bigger than common.
11. Ensure the motor cools correctly by assuring good passage of air from the fan side.
12. In the case of ambient temperatures $<-5^{\circ}\text{C}$ or $>+40^{\circ}\text{C}$ call the Technical Service.

■ CRITICAL APPLICATIONS

The performance given in the catalogue correspond to mounting position B3 or similar, when the first stage is not entirely immersed in oil For other mounting positions and/or particular input speeds, refer to the tables that highlight different critical situations for each size of reduction unit It is also necessary to take due consideration of and carefully assess the following applications by calling our Technical Service:

1. As a speed increasing.
2. Applications with especially high inertia.
3. Use as a lifting winch.
4. Use in services that could be hazardous for people if the reduction unit fails.
5. Applications with high dynamic strain on the case of the reduction unit.
6. In the places with temperature under -5°C or over 4°C .
7. Use in chemically aggressive environments.
8. Use in a salty environment.
9. Use in radioactive environments.
10. Use in environments pressures other than atmospheric pressure.
11. Mounting positions not envisaged in the catalogue.

Avoid applications where even partial immersion of the reduction unit is required.

The maximum torque that the gear reducer can support must not exceed two times the nominal torque($f_s=1$)stated in the performance tables. Intended for momentary overloads due to starting at full load, braking, shocks or other causes, particularly those that are dynamic.

	025	030	040	050	063	075	090	110	130
V5:1500 <math>n_1 < 3000</math>	-	-	-	-	-	B	B	B	B
$n_1 > 3000$	B	B	B	B	B	A	A	A	A
V6	B	B	B	B	B	B	B	B	B

A Application not recommended

B Check the application and/or call our technical service

■ BRIEF INTRODUYION TO STEPLESS SPEED VARIATOR

The design of UDL series stepless speed variator compromises the advanced technology both at home and abroad.

The products include the following main characteristics:

- High speed-regulating precision: up to 0.5-1 rotation.
- Large speed-changing range: The speed ratio ranges from 1:1.4 to 1:7 freely.
- High in strength and long in service life.
- Convenient to regulate the speed.
- Continuous in running, front-to-back in running direction, smooth in driving, stable in performance and low in noise.
- Full in sealing and suitable for any environment.
- Compact in structure and small in volume.
- Made in high-quality aluminium alloy diacast into forming, good-looking in appearance, light in weight and it never gets rusty.
- Good in adaptation: UDL series stepless speed variators can be combined with all kinds of speed reducers, as to achieve low stepless speed-changing.

UDL series stepless speed variators are widely used for foodstuffs, ceramics, packing, chemicals, pharmacy, plastics, paper-making, machine-tools, communications, and all kinds of automatic lines, pipelines and assembly lines which need speed-regulation, it is a good companion for your production.

■ STRUCTURE

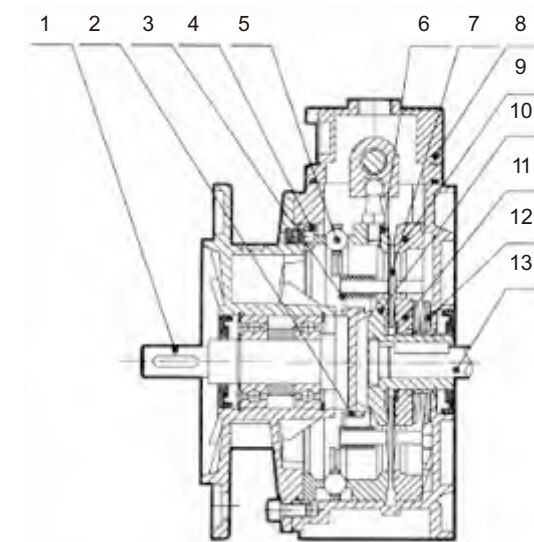

1. Output shaft
2. Planet carrier
3. Friction bearing-planet disk
4. Cam ring
5. Ball ring
6. Adjustable annulus ring
7. Planet disk
8. Control cover
9. Fixed annulus ring
10. Fixed sun race
11. Adjustable sun race
12. Belleville spring
13. Motor shaft

■ STEPLESS SPEED VARIATOR

UD - L - 0.75 B5 B5

① ② ③ ④ ⑤

NO	Comments
1	Code of stepless speed variator
2	1).L: Aluminium alloy casing 2).No mark means cast iron casing
3	Motor power
4	1).B3: Foot-mounted model 2).B5: Flange-mounted model
5	Code of installation position



UDL..B3



UDL..B5

■ COMBINATION OF STEPLESS SPEED VARIATOR AND GEAR SPEED REDUCEI

UDL - 0.75 C B5 B5

① ② ③ ④ ⑤

NO	Comments
1	Code of stepless speed variator with aluminum alloy casing
2	Motor Power
3	Code of gear reducer
4	1).B3: Foot-mounted model 2).B5: Flange-mounted model
5	Code of installation position

■ PERFORMANCE TABLE FOR UDL SERIES SPEED VARIATOR

$n_1 = 1400r/min$

B	Model	I	$n_2[r/min]$	$M_2[Nm]$
1.18KW	UDL0.18	1.6~8.2	880~170	1.5~3
0.37KW	UDL0.37	1.4~7	1000~200	3~6
0.55KW	UDL0.55	1.4~7	1000~200	4~8
0.75KW	UDL0.75	1.4~7	1000~200	6~12
1.1KW	UD1.1	1.4~7	1000~200	9~18
1.5KW	UD1.5	1.4~7	1000~200	12~24
2.2KW	UD2.2	1.4~7	1000~200	18~36
3.0KW	UD3.0	1.4~7	1000~200	24~48
4.0KW	UD4.0	1.4~7	1000~200	32~64
5.5KW	UD5.5	1.4~7	1000~200	45~90
7.5KW	UD7.5	1.4~7	1000~200	59~118

■ PERFORMANCE TABLE FOR STEPLESS SPEED VARIATOR & GEAR SPEED REDUCER

$n_1 = 1400r/min$

Model	I	$n_2[r/min]$	$M_2[Nm]$
UDL0.18-CB3	5	176~34	7~15
UDL0.37-CB3	5	200~40	15~30
UDL0.75-CB3	5	200~40	30~60

■ **OUTLINE & INSTALLATION SIZES FOR STEPLESS SPEED VARIATOR**

B3 MODEL

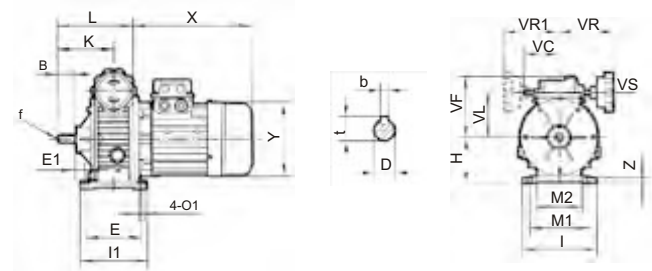

	B	Dj6	E	E1	H	I	I1	K	L	M1	M2	O1	VC	VF	VL	VR	VR1	VS	b	f	t	X	Y	Z
UDL0.18B3	23	11	105	18	80	145	120	88	136	110	71	9	71	111	78	110	110	85	4	-	12.5	200	120	10
UDL0.37B3	30	14	104	20	93	149	125	104	140	120	96	9	71	123	90	110	110	85	5	M6	16	227	141	10
UDL0.75B3	40	19	125	26	113	190	150	126	179	160	135	11	79	140	107	120	120	110	6	M6	21.5	268	160	15
UD1.1B3	40	24	105	35	100	207	130	136	187	160	115	13	-	124	102	150	-	110	8	M8	27	265	195	15
UD1.5B3	50	24	115	54	123	241	150	165	238	190	143	13	-	144	122	150	-	110	8	M8	27	290	195	18
UD2.2B3	60	30	230	25	150	300	270	191	268	245	190	14	-	188	150	150	-	110	8	M8	33	320	215	25
UD3.0B3	60	30	230	25	150	300	270	191	268	245	190	14	-	188	150	150	-	110	8	M8	33	320	215	25
UD4.0B3	60	30	230	25	150	300	270	191	269	245	190	14	-	188	150	150	-	110	8	M8	33	340	240	25
UD5.5B3	70	35	250	33	200	365	290	201	319	315	245	18	-	-	192	192	-	110	10	M10	38	395	275	30
UD7.5B 3	70	35	250	33	200	365	290	201	319	315	245	18	-	-	192	192	-	110	10	M10	38	435	275	30

B5 MODEL

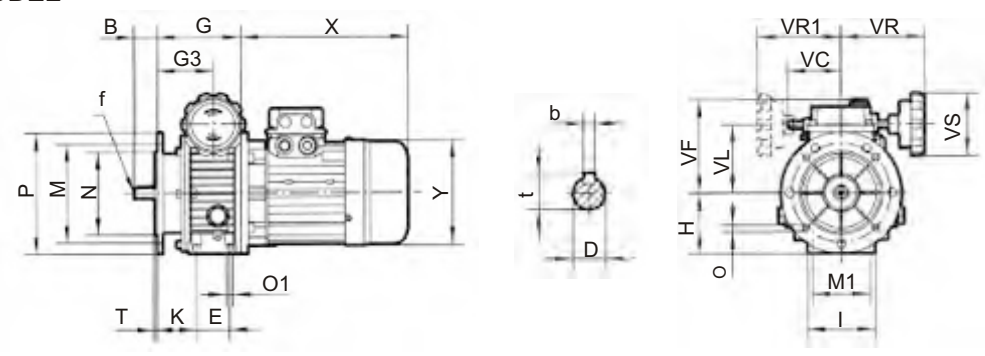

	B	Dj6	E	G	G3	H	I	M	M1	N	D	DI	P	T	K	VC	VF	VL	VR	Vr1	VS	b	f	t	X	Y
UDL0.18B5	23	11	50	113	64.5	70	72	115	60	95	9	M6	140	3.5	46	71	111	78	110	110	85	4	-	13	200	120
UDL0.37B5	30	14	40	110	74	80	90	130	77	110	9	M8	160	3.5	53	71	123	90	100	110	85	5	M6	16	227	141
UDL0.75B5	40	19	58	139	85.5	100	98	165	84	130	11	M8	200	3.5	60	79	140	107	120	120	110	6	M6	22	268	160
UD1.1B5	40	24	-	147	95	98	207	165	-	130	11	-	200	3.5	-	-	124	102	150	-	110	8	M8	27	265	195
UD1.5B5	50	24	-	188	115	126	241	165	-	130	11	-	200	3.5	-	-	144	122	150	-	110	8	M8	27	290	195
UD2.2B5	60	30	-	208	131	150	270	165	-	130	15	-	300	4	-	-	188	150	160	-	110	8	M8	33	320	215
UD3.0B5	60	30	-	208	131	150	270	265	-	230	15	-	300	4	-	-	188	150	160	-	110	8	M8	33	320	215
UD4.0B5	60	30	-	208	131	150	270	265	-	230	15	-	300	4	-	-	188	150	160	-	110	8	M8	33	340	240
UD5.5B5	70	35	-	244	131	200	-	300	-	250	19	-	350	5	-	-	-	192	194	-	110	10	M10	38	395	275
UD7.5B 5	70	35	-	244	131	200	-	300	-	250	19	-	350	5	-	-	-	192	194	-	100	10	M10	38	435	275

■ **COMBINED OUTLINE & INSTALLATION SIZES FOR STEPLESS SPEED VARIATOR & GEAR SPEED REDUCER WITH FOOT SCREWS**

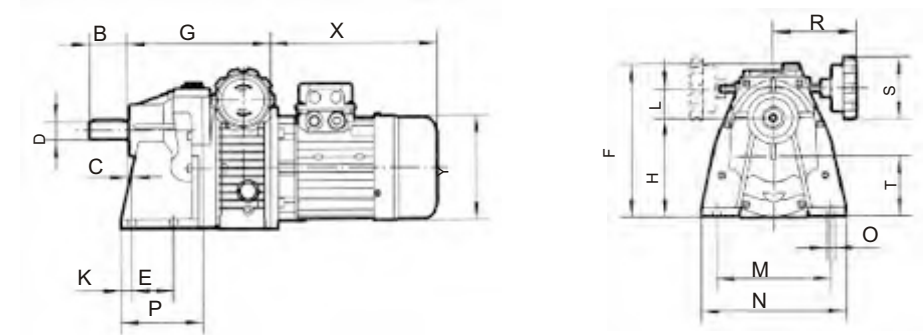

Model	B	C	D	E	F	G	H	Y	L	M	N	O	P	R	S	T	X	K
UDL0.18-CB3	40	18	19	45	162	189	108	120	33	115	130	9	80	110	85	66	200	16
UDL0.37-CB3	50	6	24	70	187	190	130	141	39	150	190	10	110	100	85	79	227	15
UDL0.75-CB3	60	7	28	70	228	225	160	160	46	165	210	130	130	110	110	99	268	25

■ **INSTALLATION POSITIONS DIAGRAM**

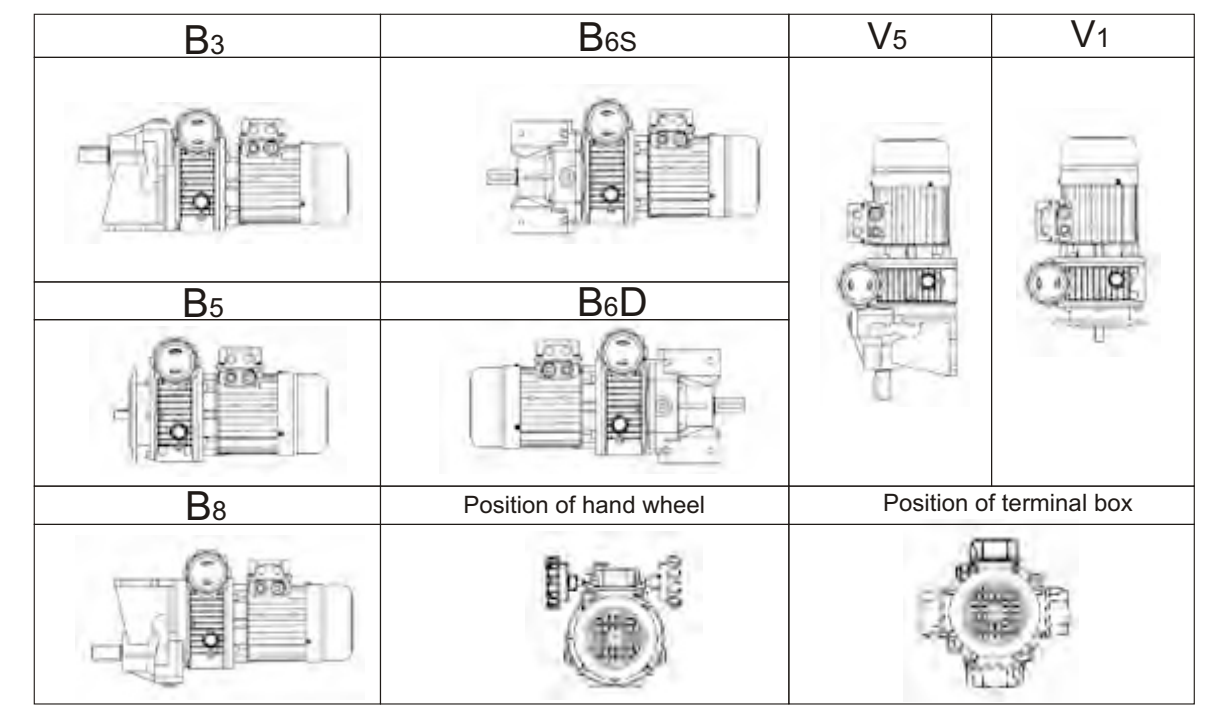

For special requirements, orders must specify the position of the terminal box with reference to the diagram. Unless otherwise specified the terminal box, the position of that will be mounted as shown in the diagram for the mounting position. Unless specified otherwise, the standard positions are B3 or B5. For positions not envisaged, it is necessary to call our Technical Service.

■ OPERATION & MAINTENANCE

- The shapes of shaft extension are all cylindrical. It is subject to GB 1569-1990 Cylindrical shaft extension. The key joint refers to GB1095-2003 Ordinary flat key.
- The shaft lines should be kept concentric when the coupling is connected with a motor. The installation error should be no more than the tolerance value of the coupling.
- When the output shaft is installed with the coupling or belt wheel, they should be pressed into the screw hole on shaft end. Or assembled by heating. No hammering on it.
- The mechanical stepless speed variator is not used in such an occasion where overload or running-blockage happened to occur.
- Speed-regulation should be effected in running. Do not turn the hand wheel of speed-regulation when the machine stops!
- The limit screws of speed-regulation on two ends under the operating box are well adjusted, Please don't touch them!
- This set is not suited to work in the environment over 40°C, especially no more than 45°C when the temperature rises. In regard to its temperature rise, please read the explanation as follows:
If a 4-pole motor is used for the speed variator, The temperature under running-in(empty running) is 40-50°C higher than that of normal working environment, After running-in up to 60-80 hours, the temperature rise will go down gradually. From that time on, it is 20°C higher than of environment; and the temperature Will keep on rising stably The high temperature rise in running will affect normal permissive working condition, but it won't bring any bad effects to the service life of parts.
- The liquid lubricating oil is used for the speed variator. Its trade mark is Ub-3x. Please check up the oil level before use.
- The machine is filled with lubricating oil before leaving factory. When it starts to work up to 2000 hours for the first time, its lubricating oil should be replaced, changing the lubricating oil every 5000hours later.
- The lubricating oil level inside the speed variator should be kept at the height of tow-third in the oil scale. Users should usually check the height of oil level. It is strictly prohibited to operate it when short of lubricating oil. The air screw nut on the operating box is screwed up for preventing from oil leakage in moving before leaving factory. It should be loosed when it starts to run. It is strictly forbidden to use it before loosing!

■ LUBRICANTS OIL CHIOSEN TABLE

	TEMPERATURE	ISO	SHELL	AGIP	ESSO	MOBIL	CASTROL	BP	GMERI	
NMRV025~09 PC063~090	-25°C~50°C	VG320	Tivela OILS320	Telium VSF320	S220	Glygoyle 30	Alphasyn Pg320	Energol SG-XP32		Synthetic oil
NMRV 110~130	-5°C~40°C	VG460	Omala Oil460	Blasia 460	Spartan Ep460	Mobilgear 634	Alpha MAX 460	Energol GR-XP460	CKE460	Mineral oil
	-15°C~25°C	VG220	Omala Oil220	Blasia 220	Spartan Ep220	Mobilgear 630	Alpha MAX 220	Energol GR-XP220		
UDL	-25°C~40°C	VG32	A.T.F.DXRON	A.T.F.DXRON	A.T.F.DXRON	A.T.F.220	TQ.DXRON-II	Autran DX	Ub-3x	Mineral oil

■ LUBRICEN FILL QUANTITY (L)

	B3	B6	B7	B8	V5	V6
NMRV025	0.023					
NMRV030	0.05					
NMRV040	0.1					
NMRV050	0.15					
NMRV063	0.3					
NMRV075	0.5					
NMRV090	1					
NMRV110	3	2.5	2.5	2.2	3	2.2
NMRV130	4.5	3.5	3.5	3.3	4.5	3.3
PC063	0.05					
PC071	0.07					
PC080	0.15					
PC090	0.16					
UDL0.18	0.13				0.2	
UDL0.37	0.15				0.25	
UDL0.55	0.33				0.45	
UDL0.75	0.33				0.45	
UD1.1	0.8				1	
UD1.5	0.8				1	
UD2.2	1.2				1.2	
UD3.0	1.2				1.2	
UD4.0	1.2				1.2	

■ LUBRICATION

In case of ambient temperatures not envisaged in the table, call our Technical Service.

○ In the case of temperature under -30°C or over 60°C it is necessary to use oil seals with special material.

○ For operating ranges with temperature under 0°C it is necessary to consider the following: The motors need to be suitable for operation at the envisaged ambient temperature.

→ The power of the electric motor needs to be adequate for exceeding the higher starting torques required.

→ In the case of reduction units with a cast-iron case, pay attention to impact loads since cast iron may have problems of fragility at temperatures under -15°C

→ During the early stages of service, problems of lubrication may arise due to the high level of viscosity taken on by the oil and so it is wise to have a few minutes of rotation under no load.

○ The oil needs to be changed after approximately 10,000 hours. This period depends on the type of service and the environment where the reduction unit works.

○ The reduction units size 025-030-040-050-063-075-090 are supplied complete with lubricant for life, synthetic oil (SHELL TEVELA OIL 320), and can therefore be mounted in any position envisaged in the catalogue, V5/N6 for which you should call our Technical Service to assess the condition of use.

○ The reduction units size 110 and 130 are supplied complete with lubricant, mineral oil, (SHELL TEVELA OIL 320)

○ The variator speed are supplied complete with lubricant, mineral oil (GMERl Ub-3x).

○ For size 110 and 130 it is necessary to specify the position, otherwise the reduction units are supplied with the quantity of oil relating to pos.B3.

○ Only reduction units 110 and 130 are fitted with breather, level and oil drainage plugs. It is necessary, after installation, to replace the closed plug used for transportation with the breather plug supplied with the unit.

○ PC is supplied complete with life-long lubricant, synthetic oil (SHELL TEVELA OIL 320), and can therefore be mounted in all the positions.

■ NOTICE FOR ORDERING

1. Please refer to the sheet of performance parameter, NMRV series dimensions, Mounting and operation diagram, make reasonable choice of model, and write down model mark to your required revolution scope, output torque and structural form on ordering (when ordering, you should show whether the reducers are equipped with motors, otherwise reducers aren't supplied with motors.)

2. Please make the best choice of standard products in this catalogue, and give an additional explanation for your special requirement and motors.

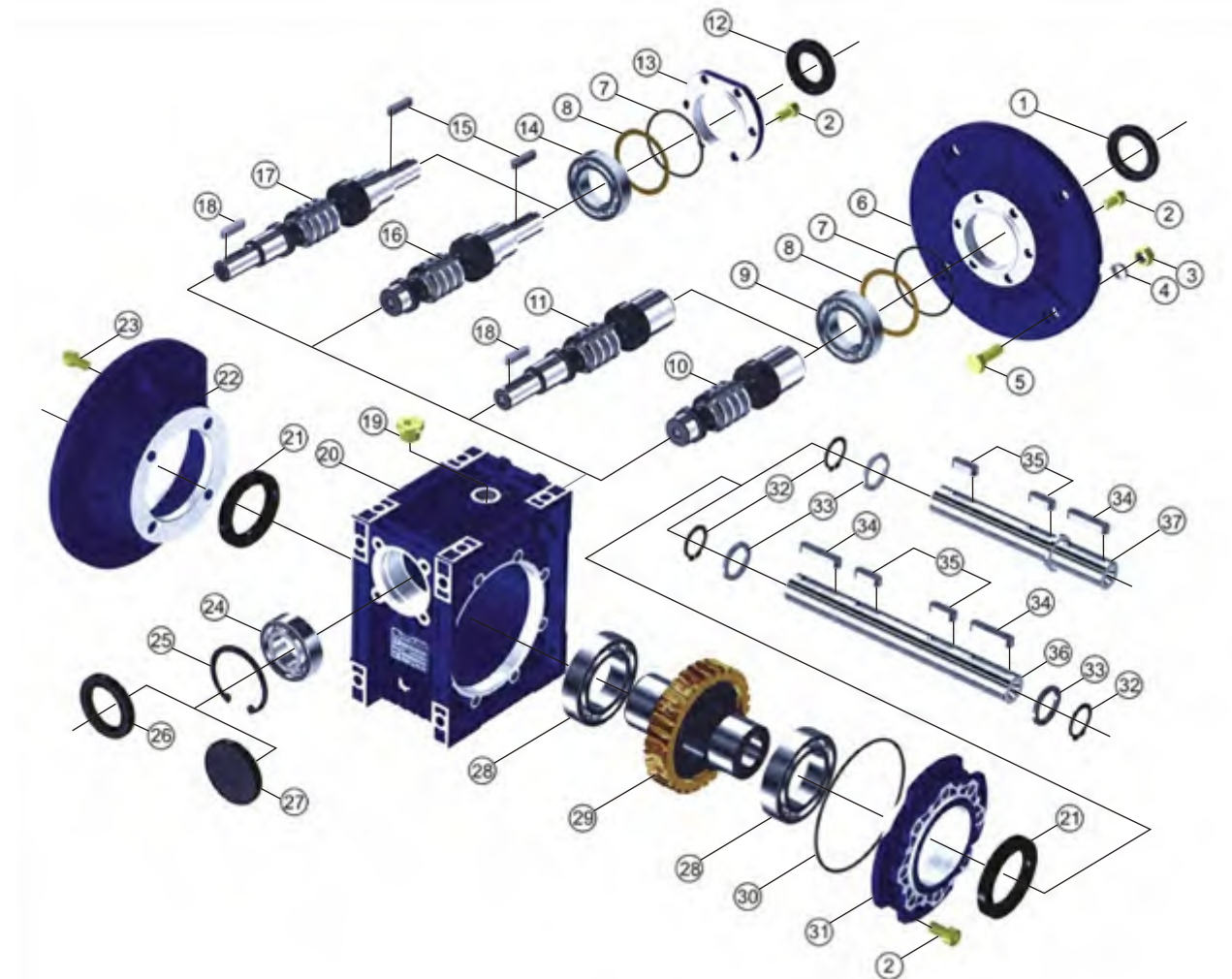

- | | |
|--------------------------------------|------------------------|
| 1.oil seal | 20.casing |
| 2.inner hex screw | 21.oil seal |
| 3.nut | 22.output flange |
| 4.spring washer | 23.inner hex screw |
| 5.hex screw | 24.bearing |
| 6.input flange | 25.hole-circlip |
| 7.O-Ring | 26.oil seal |
| 8.adjust spacer | 27.cover |
| 9.bearing | 28.bearing |
| 10.hole input worm | 29.worm wheel |
| 11.hole input and shaft output worm | 30.O-Ring |
| 12.oil seal | 31.output cover |
| 13.input cover | 32.shaft-circlip |
| 14.Bearing | 33.spacer |
| 15.key | 34.key |
| 16.shaft input worm | 35.key |
| 17.shaft input and shaft output worm | 36.double output shaft |
| 18.key | 37.single output shaft |
| 19.oil plug | |