



**COOLANT PUMP
CATALOGUE**



About Us

Miksan Motor Sanayi ve Ticaret A.Ş. was founded in Hasköy, Istanbul in 1977 to produce 71 frame squirrel cage electric motors.

In 1982, Miksan Motor began manufacturing immersion pumps to meet domestic markets demand. In 2003, we extended our product range with vibration motors and have launched a new factory in Bulgaria within the borders of the European Union. This leads to an increase in production capacity, improvement in distribution and decrease in delivery time significantly.

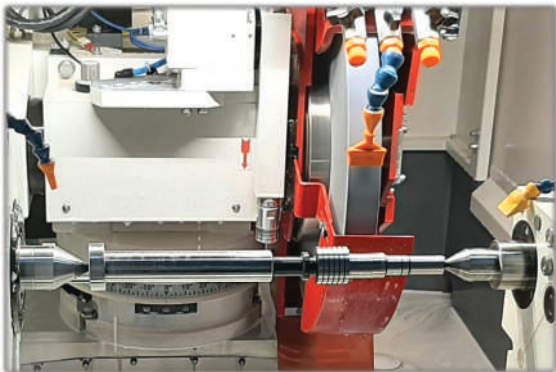

In 2012, we moved our factory to Beylikdüzü, Istanbul. Currently, within the area of 9000 m². Miksan Motor started to produce Explosion-Proof electric motors for 2D zone 21 & 22 and 2G zone 1 & 2 since 2016. We received certification for TX series Ex-proof motor for 3D zone 22 in 2018. Our factory in Bulgaria has been expanded in 2016 and factory in Türkiye has been expanded and had a new appearance in 2018.

We are producing asynchronous electric motors (56 frame to 132 frame three-phase and 56 to 100 frame single phase with permanent capacitor), the electric motors for special applications with specially designed shaft and flange (like burners etc.), vibrators and immersion pumps. Our products meet all the requirements of the related IEC, DIN and TSE standards.

R&D



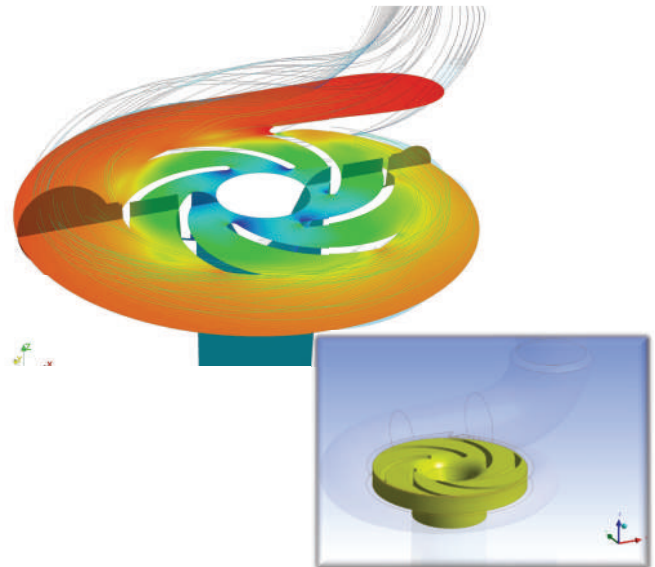



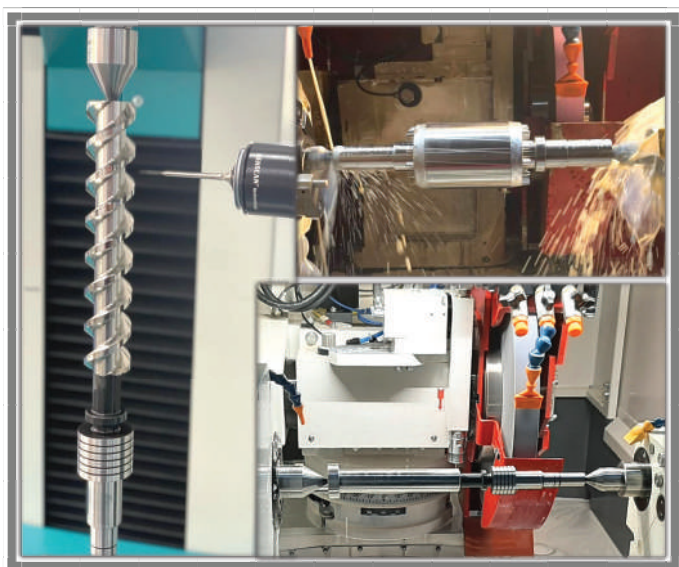
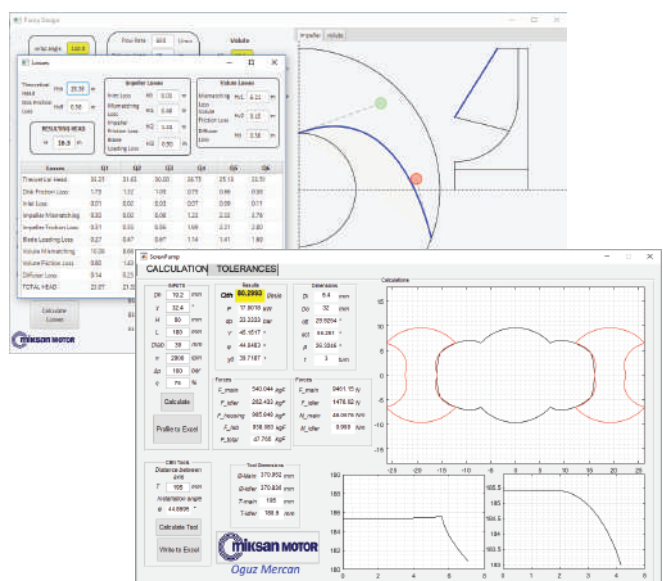

Our company continues its pioneering role in production of immersion pumps for domestic market. The R&D studies for immersion pumps used for the circulation of the coolant and cutting fluids have been progressively increased. In recent years, R&D department of the company is equipped with the up-to-date engineering tools. As a result of R&D studies, the new types of immersion pumps with high efficiency are designed, manufactured and added to our product range. All the detailed performance characteristics of the immersion pumps can be performed and reported in our company.













The use of high efficiency pumps, with modular mechanical structure, designed and produced in recent years, decreases the cost of life time maintenance and operation. Miksan Motor has it's own software for hydraulic design calculations of impeller, diffuser, volute and screw spindles.



OVERVIEW OF PUMPS

PUMPS									
		AP / BP	CP 1 / CP 2	EP 150 / 250 / 350 / EPV	GP / GPA / GPF / GPH	IP / IPA / IPF / IPH	J Series	HC / HD	HCA / HDA
Pump Specifications	Mounting Position	Vertical	Vertical	Vertical	Vertical	Vertical	Vertical	Horizontal	Vertical
	Impeller Type	Open	Open	Open	Open (+ Axial)	Open (+ Axial)	Open (+ Axial) Vortex	Closed	Closed
	Housing	PP / Al	Cast Iron	Cast Iron	Cast Iron	Cast Iron	Cast Iron	Cast Iron	Cast Iron
	Volute / Diffuser	PP / Al	PP / Cast Iron	Cast Iron	Cast Iron	Cast Iron	Cast Iron	Stainless St.	Stainless St.
	Shaft	Eng. St (opt. Stainless St.)	Engineering Steel	Engineering Steel	Engineering Steel	Engineering Steel	Engineering Steel	Stainless Steel	Stainless Steel
	Impeller	PP / Al	PP / Brass	Cast Steel	Brass	Cast Steel	Cast St./Cast I.	Stainless St.	Stainless St.
	Mechanical Seal	-	-	-	-	-	-	C - SiC - Viton	C - SiC - Viton
	Pipe Connection	G ¾	G ¾	G 1 ¼	G 1 ½	G 1 ½	G 2 / G 2 ½	G 1	G 1
	H _{max} (m)	5.3 / 5.4	6.7 / 7.7	33/36/13	105	105	90	72 / 60	72 / 60
	Q _{max} (l/min)	63 / 67	105 / 125	185/255/360	450	630	1700	85 / 150	85 / 150
H _{opt} (m)	2 - 4 / 2 - 4.5	2.2 - 5.7	Please look at the product pages for optimum working ranges.						
Q _{opt} (l/min)	44 -20/52 -20	74 - 30							
Motor	Power (kW)	0.09	0.25	0.37 - 1.5	1.1 - 5.5	1.1 - 11.0	1.5 - 11.0	0.37 - 1.1	0.37 - 1.1
	Protection Degree	IP 54	IP 54	IP 55	IP 55	IP 55	IP 55	IP 55	IP 55
	Isolation Class	F	F	F	F	F	F	F	F
Fluid Specifications	Kinematic Viscosity	30 /45 mm ² /s	1...90 mm ² /s	1...90 mm ² /s	1...90 mm ² /s	1...90 mm ² /s	1...90 mm ² /s	1...30 mm ² /s	1...30 mm ² /s
	Temperature	0...60 °C	0...60 °C	0...80 °C	0...80 °C	0...80 °C	0...80 °C	0...80 °C	0...80 °C
	Chip Size - max (mm)	5	6	8	8	8	10 - 50 (JD)	2	2
	Cutting Oils	+	+	+	+	+	+	+	+
	Grinding Oils	+	+	+	+	+	+	+	+
	Coolants	+	+	+	+	+	+	+	+
	Water	+ / -	o	o	o	o	o	o	o
	Paint / Ink	-	-	-	-	-	-	-	-
Chemical Liquids	+ / -	-	-	-	-	-	-	-	
Applications	Cutting	+	+	+	+	+	+	+	+
	Boring	+	+	+	+	+	+	+	+
	Turning	+	+	+	+	+	+	+	+
	Milling	+	+	+	+	+	+	+	+
	Grinding	+	+	+	+	+	+	o	o
	Deep Hole Boring	-	-	-	-	-	-	-	-
	Erosion	-	-	-	-	-	-	+	-
	Filtration Systems	-	+	+	+	+	+	+	+
	Printing Processes	-	-	-	-	-	-	-	-
	Circulation Systems	+	+	+	+	+	+	+	+
Coolant Systems	-	-	-	-	-	-	-	-	
Page	14 -17	18 - 19	20 - 27	28 - 33	34 - 39	40 - 55	58-59/ 64-65	60-61 / 66-67	

Description of the signs : + Applicable - Not applicable o Contact us before selection

									
HCB / HDB / HEB	HCD/HDD / HED	H series 60 Hz	FP 40-42-43 / FP 90	KEP Series	LP Series	DP Series	T Series	CP Ex	VP Series
Vertical	Vertical	Vertical	Vertical	Self-Priming	Inline	Vertical	Inline	Vertical	Ver. / Hor.
Closed	Closed	Closed	Peripheral	Open	Open	Open	Open	Open	Three Spindles
Cast Iron	Cast Iron	Cast Iron	Cast I./Bronze	Cast Iron	Cast Iron	PPS	Cast Iron	Cast Iron	Cast Iron
Stainless St.	Stainless St.	Stainless St.	Cast I./Bronze	Cast Iron	Cast Iron	PPS	Cast Iron	Cast Iron	Cast Iron
Stainless Steel	Stainless Steel	Stainless Steel	Engineering St/ Stainless St.	Stainless Steel	Stainless Steel	Stainless Steel	Engineering Steel	Engineering Steel	Hardened Steel
Stainless St.	Stainless St.	Stainless St.	Brass	Cast Iron	Cast Iron	PPS	Brass	Brass	Hardened St.
C - SiC - Viton	C - SiC - Viton	C - SiC - Viton	-	C - SiC - Viton	SiC-SiC-Viton	-	C - SiC - Viton	-	-
G1 / G2	G1 / G2	G1 / G2	G ¾	G1 / G1¼ / G2	G1 / G1¼ / G1½	G 1	G ¾	G ¾	G 1 / SAE 1
250 / 235	250 / 235	250	35-65-95 / 60	10 / 40	25	30	21 / 24	6.7	1000
85 / 150 / 300	85 / 150 / 300	300	46-50-53 / 60	100 / 750	500	60 / 110 / 160	40 / 65	105	78
Please look at the product pages for optimum working ranges.								2.2 - 5.7	-
								74 - 30	-
1.1 - 11.0	1.1 - 11.0	0.37 - 11.0	0.40-1.5 / 1.1	0.25 / 3.0	0.25 / 2.2	0.09 - 0.75	0.25 / 0.55	0.37	1.1 - 22
IP 55	IP 55	IP 55	IP 55	IP 55	IP 55	IP 55	IP 55	IP 55	IP 55
F	F	F	F	F	F	F	F	F	F
1...30 mm ² /s	1...30 mm ² /s	1...30 mm ² /s	1...90 mm ² /s	1...30 mm ² /s	1...90 mm ² /s	1...12 mm ² /s	1...60 mm ² /s	1...90 mm ² /s	1...400 mm ² /s
0...80 °C	0...80 °C	0...80 °C	0...80 °C	0...60 °C	0...60 °C	0...60 °C	0...80 °C	0...60 °C	0...80 °C
2	2	2	0	6 - 12	5 / 8	4	0	6	0
+	+	+	+	+	+	+	+	-	+
+	+	+	+	+	+	+	+	-	+
+	+	+	+	+	+	+	+	-	+
o	o	o	o	+	+	+	o	-	-
-	-	-	-	-	-	+	-	+	-
-	-	-	-	-	-	+	-	-	-
+	+	+	+	+	+	+	+	+	+
+	+	+	+	+	+	+	+	+	+
+	+	+	+	+	+	+	+	+	+
+	+	+	+	+	+	+	+	+	+
o	o	o	-	-	-	-	+	+	+
+	+	+	-	-	-	-	-	-	+
-	-	-	-	-	-	-	-	-	+
+	+	+	-	+	+	-	+	+	+
-	-	-	-	-	-	+	-	+	-
+	+	+	+	+	+	+	+	+	+
-	-	-	+	+	+	+	-	-	+
62-63 / 68-71	72 - 77	78 - 97	98 - 101	102- 111	112 - 121	122 - 129	130 - 131	132 - 133	134 - 151

Description of the signs : + Applicable - Not applicable o Contact us before selection

Pump Selection Steps

1. Operating Area and the Application of Pump

<i>Machine Tools</i> Turning Milling Grinding Cutting Drilling Deep-Hole Drilling Erosion	<i>Filtration Systems</i> Central Filtration Vacuum Filtration Separators	<i>Recirculation Apps.</i> Circulation Fluid Transfer	<i>Other Apps.</i> Please contact us for technical support Tel: +90212 284 64 00 e-mail: miksanteknik@miksánmotor.com
--	--	---	---

Fluid Specification (Medium) :.....
 Application :.....

Please check for the proper pump on page 2.

2. Does fluid (medium) contain solid particles?

Yes

No

Please check for the proper pump on page 2 regarding the maximum solid particle size.

Does efficiency have priority?

Yes

No

Prefer closed-impeller pump

Prefer open-impeller pump.

3. Choose the right pump model between marked pumps on previous steps according to operation point as head and flow rate.

4. Power control of electric motor

Viscosity of the Fluid

1.....30 cSt

30.....90 cSt

> 90 cSt

All the pump performance curves in the catalogue can exactly be used.

Pump performance curves in the catalogue can not exactly be used.
 Please contact us for curve transformation.

Please contact us for pump selection.

TECHNICAL INFORMATION

Miksan immersion pumps can be used with various types of fluid. Although these fluids can be clean, they may contain certain size of solid particles. The impellers used in the pumps can be categorized as open impellers, closed impellers, peripheral impellers, and vortex impellers, as shown in Figure 1.

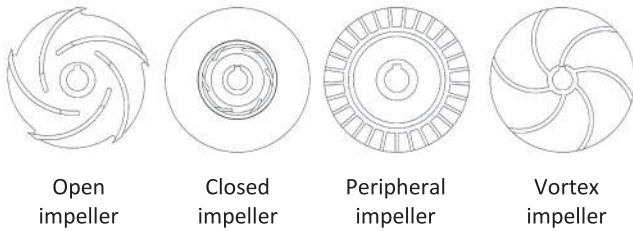

Figure 1 - Impeller types

Pumps with closed impellers have higher efficiency than the one with open impellers, and are usually used to pump filtered or less dirty fluid, while the pumps with open or vortex impeller are used in the applications containing solid particles in a certain size.

Operating Conditions

The impeller of the pumps used in machine tools has to be fully immersed into the fluid in the tank as shown in the Figure 2. Pump has to be properly placed on the tank in order to achieve required suction. Distance between the pump suction opening and bottom of tank must be at least 30 mm. Also fluid level in the tank should not fall under the level of first impeller of the pump, and the maximum level should not exceed the rubber ring on the pump shaft.

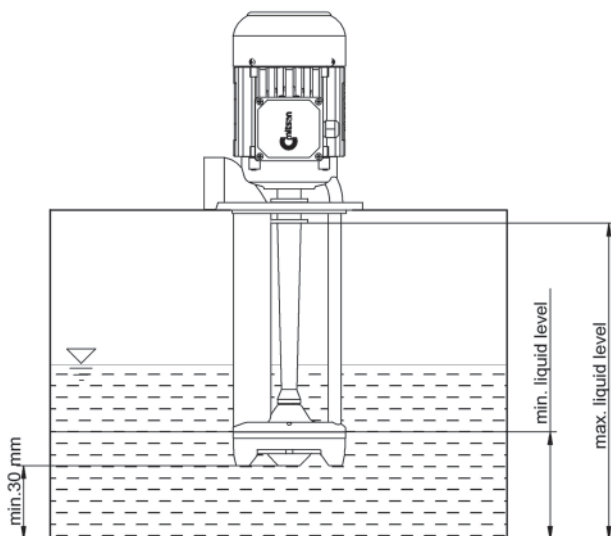

Figure 2 - Pump position inside the coolant tank

Pumps equipped with inducer (axial impeller), shown in Figure 3, should especially use in the tanks that have an important level variation of the fluid. As long as inducer is immersed in fluid, pump operates without any suction problem. Since inducer is located under the impeller, fluctuations in liquid level become less important. (Please check GPA/IPA and JBA series pumps for detailed information)

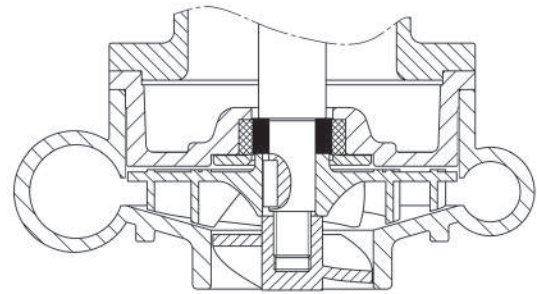

Figure 3 - Section of a pump with inducer

The use of pumps with an inducer is recommended for the medium that contains foam layer that occurs in high-speed machinery operations (e.g. grinding). For example, when high-speed surface grinding operation on a work piece is in progress, the foam layer occurs on the medium free surface in the tank. Standard radial impeller pumps cannot transfer the liquid-air mixture (foam). Therefore the continuous flow of the coolant fluid cannot be provided on the work piece. Distortions occur on the surface of the work piece. Pumps with an inducer overcome all these undesired difficulties. Also, grinding wheel lasts longer.

In addition to this, pumps with an inducer prevent the accumulation of the chips in the bottom of the tank. Inducer (axial impeller) quickly sucks the chips (e.g. aluminium, steel) inside the tank resulting from machining processes (e.g. turning, milling) and pumps directly to the filtering systems.

As it is well known, the high temperature of the fluid increases the risk of cavitation of the pump. In this case, inducer takes the cavitation damage.

The GPF/IPF series pumps with axial impeller are designed for vacuum filters. They have axial and radial impeller. O-ring is placed in the pump suction end to prevent the pressure loss. (Please check GPF/IPF series pump for detailed information)

Pump Types

Pumps can be classified as either positive displacement machines or dynamic machines according to their energy conversion principle. In the positive displacement pumps, fluid is directed into a closed volume. The fluid pressure is increased by squeezing it with the movement of the boundary of the closed volume from the suction to the discharge. FP, T, VP type of pumps are the examples of the positive displacement pumps. An example of a peripheral impeller of a positive displacement pump is shown in Figure 4.

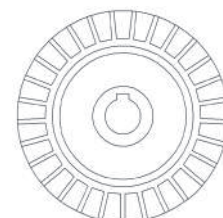

Figure 4 - Peripheral impeller of FP90 pump

The typical variation of the head with flow rate of a positive displacement pump is shown in Figure 5. Theoretically, it is a vertical line passing through a certain flow rate determined by the pump geometry and the speed of the driver. In reality, leakage occurs between stationary and moving surfaces and it increases with the increasing pressure.

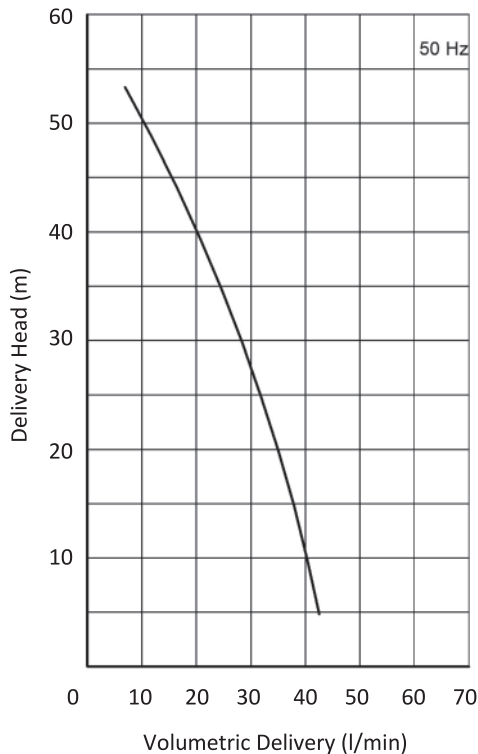

Figure 5 - Performance curve of FP 90 pump (an example of volumetric pumps)

In dynamic pumps, mechanical energy is converted to the pressure by changing the momentum of the fluid which is different than that of positive displacement pumps. An example of characteristic curve of dynamic pumps is shown in Figure 6. The pump head is a function of flow rate. All types of Miksan Motor pumps, except FP, T and VP screw pump series are dynamic pumps.

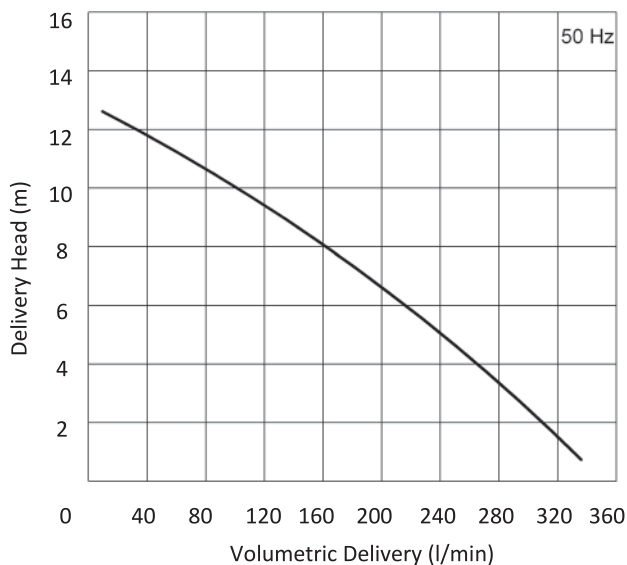

Figure 6 - Performance curve of rotodynamic EP 350 pump

Basic Pump Terms

- Flow rate (Q) : The volume of fluid passing through the pump per unit time. [l/min, m³/h]
- Delivery Head (H_m) : Energy transferred to the fluid particles. [mss]
- Motor Power (P₁) : Power supplied to electric motor. Unit kW
- Shaft Power (P₂) : Power that transferred to the pump shaft. Unit kW
- Hydraulic Power (P) : Power gained by fluid through the inlet and outlet of the pump. Unit kW
- Pump Efficiency (η) : Ratio of the power transferred to the fluid to shaft power.
- Motor Efficiency (η_{motor}): Ratio of the shaft power to the motor power.
- Density (ρ) : Mass of fluid per unit volume. Unit kg/m³
- Acc. of gravity (g) : 9,81 m/s²
- NPSH : Net Positive Suction Head (m)

Hydraulic Power : $P = H_m \cdot Q \cdot \rho \cdot g$

Pump Efficiency : $\eta = \frac{H_m \cdot Q \cdot \rho \cdot g}{P_1}$

Shaft Power : $P_2 = \eta_{motor} \cdot P_1$

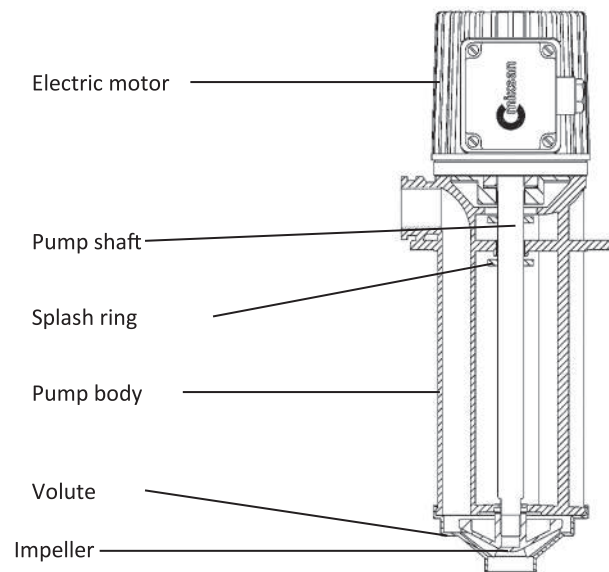

Figure 7 - Main components of the pump

Performance Curves of Pumps

Performance characteristics of rotodynamic pumps show the variations of the head (H_m), shaft power (P), efficiency (η), and net positive suction head (NPSH) with the flow rate (Q) at constant speed as shown in Figure 8.

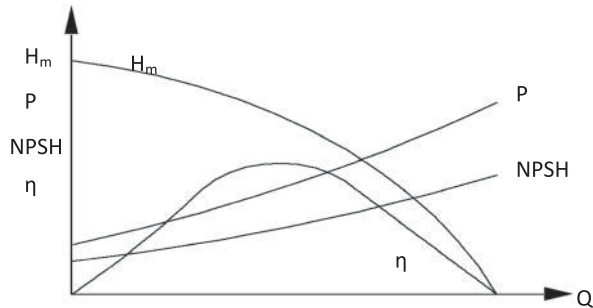

Figure 8 - Characteristic curves of rotodynamic pumps

These curves do not change as long as the pump speed and flow conditions at the suction (uniform flow conditions) are constant. Concerning the energy saving, the pump should run around the best efficiency point as shown in Figure 9.

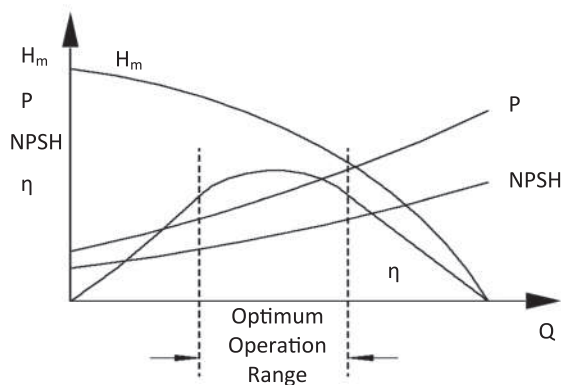

Figure 9 - Optimum operation range of the pump

The operating point of the pump is determined by the system characteristic. NPSH defines the cavitation characteristics of the pump. NPSH has to be taken into account when the level of suction flange of the pump is above the free surface of the liquid in the tank shown in System A, Figure 10. For pump types of HC, HD and T, the calculation of NPSH should be performed and then the maximum suction head can be determined. Calculated NPSH value has to be larger than the given NPSH value in order to prevent cavitation.

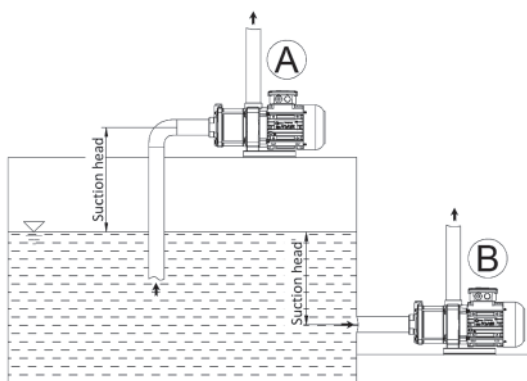

Figure 10 - Operation positions of horizontal pumps

Suction head is usually not considered for the pumps that are used for machine tools and for those applications where suction of the pump is below the free surface as shown in Figure 10, B, and Figure 2. Therefore NPSH characteristics of the immersion pumps are not given in the catalogues.

Determining of The Operating Point

Intersection point of the parabola representing the system characteristic and the pump $H_m - Q$ curve corresponds to the pump running point. Shaft power and efficiency can be found by using the pump flow rate.

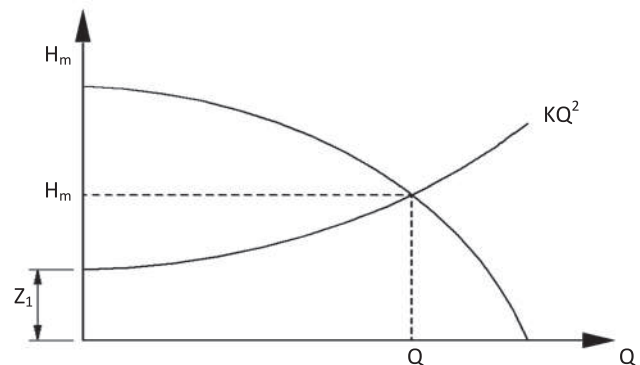

Figure 11 - Determining of the operating point

Hydrodynamic characteristics of the system can be expressed as $Z + KQ^2$. In this expression, K is a coefficient that consists of minor and major loss coefficients. Z is the elevation difference between the tank fluid free surface and discharge point. Q is the flow rate of the system. The variation of the system characteristics results in variation of the operating point of the pump.

Pump Selection

The major subjects that have to be considered in the pump selection are:

- 1-) Properties of Liquid: Viscosity, temperature, involving solid particles or not, size of solid particles,
- 2-) Mechanical Properties of the Pump: Type, material of pump body and shaft, impeller type, impeller material, mechanical seal,
- 3-) Hydrodynamic Properties of the Pump: Head, flow rate, rotational speed, output power, efficiency, NPSH .

Serial and Parallel Connection of The Pumps

Pumps can be connected in serial or parallel to obtain higher pressure or higher flow rate respectively. Connection types are shown in the figures and diagrams below.

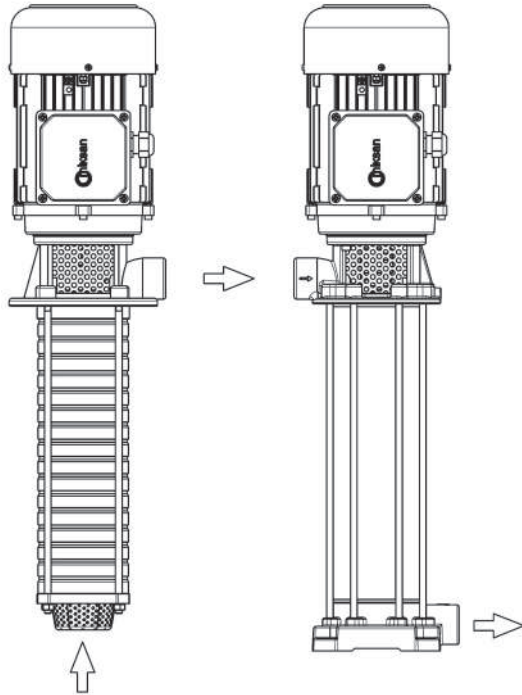

Figure 12 - Serial connection of the pumps

In case of serial connection, the discharge of the first pump is connected to the suction of the second impeller as shown in Figure 12. Therefore the head of the pumps is determined by means of $H_{m\ total} = H_{1m} + H_{2m}$ as shown in Figure 13.

Pumps are connected in parallel to increase the flow rate. In this case, both pumps suck the fluid from the tank and pump it to the collector shown in Figure 14. The flow rate of the system is calculated by means of $Q_{total} = Q_1 + Q_2$ as shown in Figure 15.

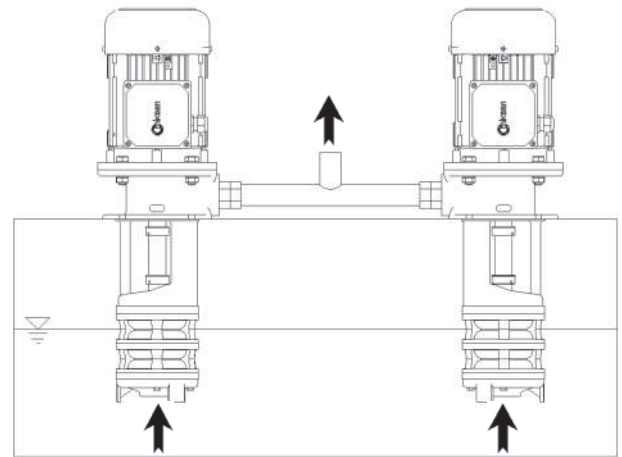

Figure 14 - Parallel connection of the pumps

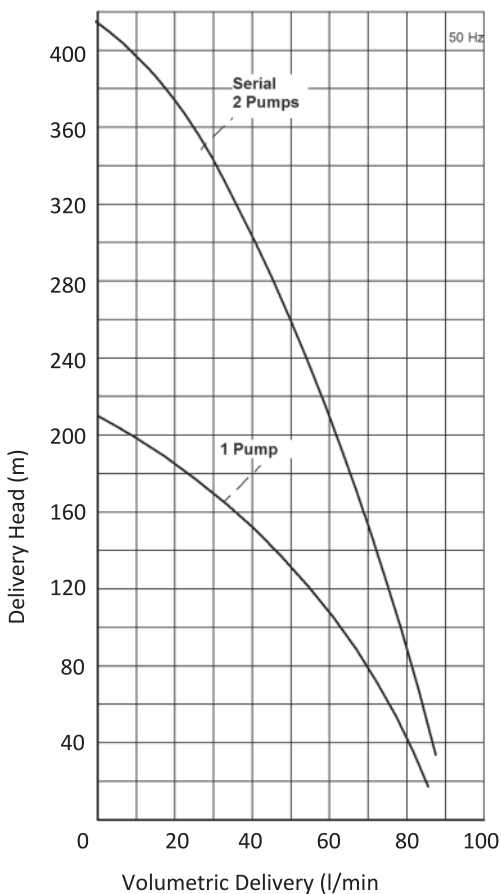

Figure 13 - Performance curve of the serial connected pumps

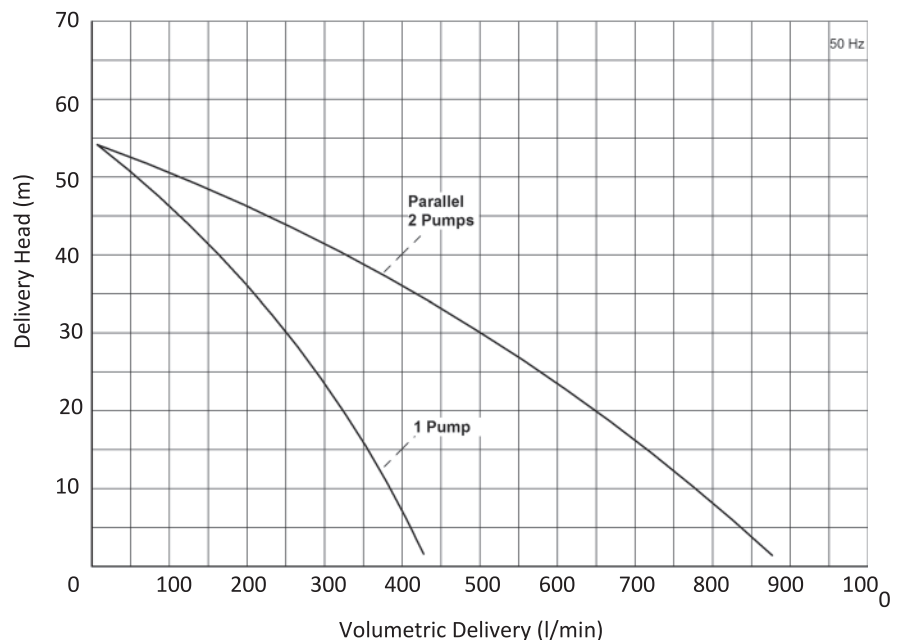

Figure 15 - Performance curve of the parallel connected pumps

Speed Control

It is possible to use our pumps with a frequency converter. The performance curves of the pumps in this catalogue are given for the frequency of 50 Hz. Pump performance curves changes with the rotational speed of the impeller. This is generally done with the use of frequency converter. This makes the operating region of the pump larger shown in Figure 16.

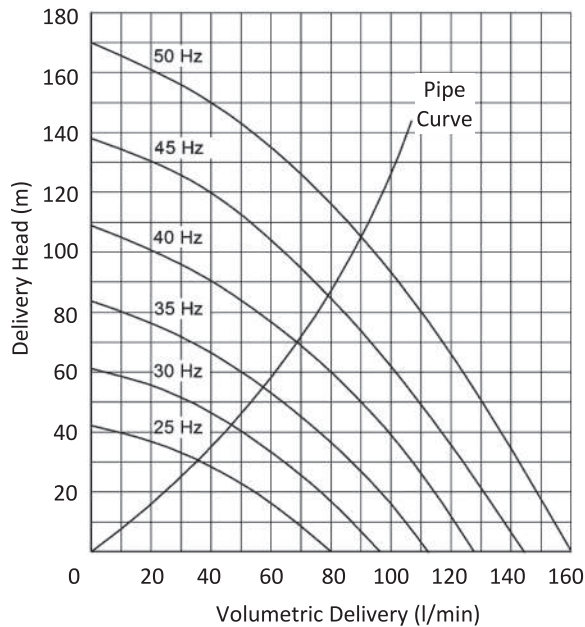

Figure 16 - Frequency control

In case of systems with many pumps, the optimization of the operating points of pumps can be found by using the frequency converters through the control system for energy saving. In this case feedback can be provided by measuring the H and Q values of the each pump continuously.

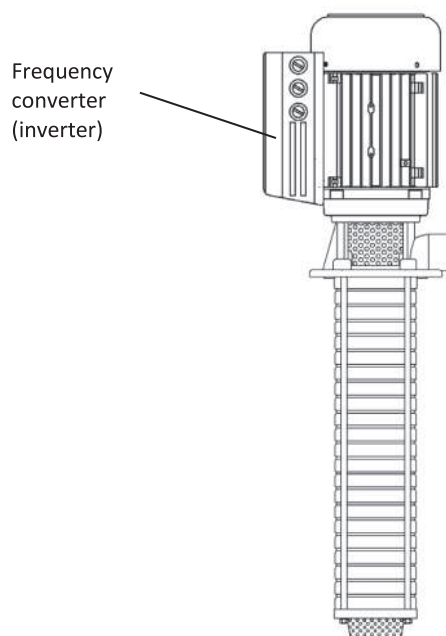

Figure 17 - An inverter on the pump

The advantages of the use of frequency convertor in the driven unit of the pumps are given in the following:

- Frequency converter runs with the fixed voltage to frequency ratio. Thus, current of motor becomes constant. Hereby, the current of the motor will not reach excessive values and therefore the energy losses will decrease.
- For the systems with variable flow rate, the use of frequency converter can provide energy saving.
- Frequency converters enable to increase the speed of the pump above the nominal values, so pump can be operated above the nominal Q-H curve.
- Frequency converters provide the flexibility to the system.
- Frequency converters provide the soft starting for the driving unit.

Effects of Viscosity

Viscosity is one of the most important parameters at the pump selection and is defined as the resistance of fluid against the flow. Miksan Motor centrifugal pumps are designed to operate in a coolant with a wide range of viscosity at machining, circulating and cooling processes, filtration system, etc. The ranges of kinematic viscosity of the pumped medium are given in the product pages for all types of Miksan Pumps. The performance curves of pumps given in the product pages are measured by using the clean water with the kinematic viscosity of 1 mm²/s (cSt) and density of 997 kg/m³ (according to ISO 9906:2012 Grade 3B).

Performance curve of the pump will change with the use of medium that has a viscosity different than water as shown in Figure 18 for JB 420 series of Miksan pumps.

There are various methods to convert the performance curves of pumps which is obtained with water to the one of with different viscosity than water (American Hydraulic Inst. – Viscosity correction standard). The most critical issue for pumping the medium with high viscosity is the motor power. It may require a motor with the high power (Please contact us for technical support).

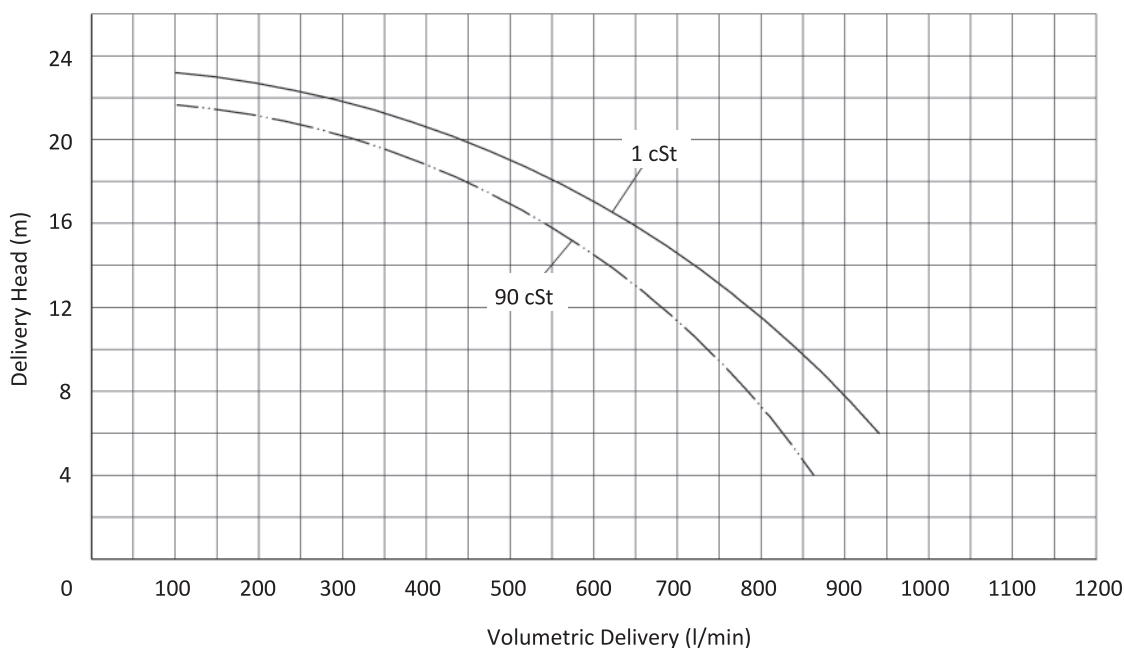

Figure 18 - Effect of viscosity to the performance curve

ELECTRICAL INFORMATION

Miksan branded centrifugal pumps run by the Miksan branded motors which are confirmed with the EN 60034-1 standard. Unless indicated otherwise, our electric motors ($\geq 0,75$ kW) have IE3 efficiency according to the EN 60034-30 standard.

Safety Instructions

- The electrical installation of the pump must be performed by an authorized electrician.
- Any kind of repair should be avoided without cutting of the electric energy and stopping the pump.
- The pump's electrical connection box must not be submersed.
- Direction of the pump should be set according to the label on its housing. For reverse rotation, position of two energy cables must be changed.
- Working in different voltage level and frequency must be avoided. Voltage level and frequency information can be found on the label of the motor.
- Under normal conditions, all of the metal parts must be grounded with the help of ground terminal inside the terminal box by using the appropriate cable. Ungrounded metal parts pose a risk to human life!
- To prevent the risk of electrical shocks and reduction in the degree of mechanical protection, terminal box cover gasket and all mounting screws, must be tighten properly.
- In order to prevent injuries, close the motor's cooling impeller with its lid and tight it with screws.
- During the working period, protect the motor's cooling system (housing and air supply) from dust, oils and do not operate the pump with any missing parts to prevent overheating problems mostly as a result of failure of the cooling system.
- Periodically check the tightness of all electrical and mechanical connections.

Electrical Connections

- Installation of the electrical cables must be performed by an authorized electrician as it does not touch the motor housing or piping.
- Check the values of voltage, frequency, number of phase and current information from the label of the motor and pump information pages and make suitable connections. Otherwise, pump will not work properly.
- According to the current value indicated on the label of the motor, choose appropriate protective system (protect the motor via circuit breaker, thermal-magnetic circuit breaker or fuse).
- Electrical connection of the motor may be changed depending on the power and voltage of the motor. For example, (Y) 400 V/ 230 V(Δ) motor, must have star connection with 400 V phase to phase voltage, and have delta connection with 230 V phase to phase voltage. You can see the star and delta connection on Figure 19.

Note: Motor will burn if you use delta connection instead of star connection due to high voltage, and if you use star connection instead of delta connection, it will run with low power due to low voltage.

If the motors' power is higher than 4 kW, delta connection must be used. For low starting current, star-delta connection is recommended. Here, the duration of passing to delta connection must be short.

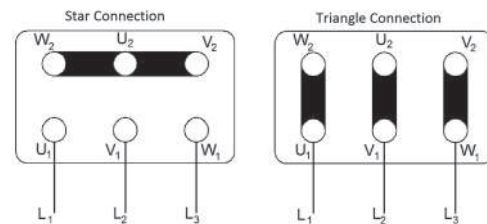

Figure 19 - Star and delta connection Y/ Δ

While Operating

- Do not run dry.
- The pump operates in silence and without vibration. When high vibration and noise is recognized, cut the power off, and check the mechanical and electrical connections.
- Direction of the pump should be set according to the label on its housing. For reverse rotation, position of two of the energy cables must be changed.
- The current of the pump must be monitored. If the current is less than the value in the label, it is possible that motor is running with no load. If the current is above the value of the label, temperature of motor will increase and thereby motor winding will finally burn out. The possible reasons of excessive current are entrance of foreign particles to the pump impellers, damaged bearings, lack of phase and unbalanced voltages between the phases. Motor has to be protected with proper fuse to prevent similar problems,

Voltage Rate and Frequency

- Voltage level is indicated in the information pages. (Voltage tolerance is ± 10 according to EN 60034 -1)
- It is possible to design pumps for different voltage level and frequency. For this kind of inquiry, please contact with our technical department.

Cable Selection

Voltage fluctuations in the system and current-carrying capacity of the cable must be considered when selecting the required cable.

Voltage drop calculation is shown below;

$$3 \text{ PHASE LOAD} - 230 \text{ V}/400 \quad \%e = 0,0124 \cdot \frac{P \cdot L}{S}$$

$$1 \text{ PHASE LOAD} - 230 \quad \%e = 0,074 \cdot \frac{P \cdot L}{S}$$

$\%e$: Voltage Drop
 P : Power (kW)
 L : Cable Length (m)
 S : Cable Cross-section(mm²)

Voltage drop percentage of an interior wiring, for continuous greatest current and voltage between terminal box and consumption tools, should not exceed 3% according to the standards.

It is possible to find current-carrying capacity information from the cable supplier. So, appropriate voltage may supply to the motor by selecting proper cross-section of wire. As mentioned before, operating non-nominal voltage value can cause burning of the motor.

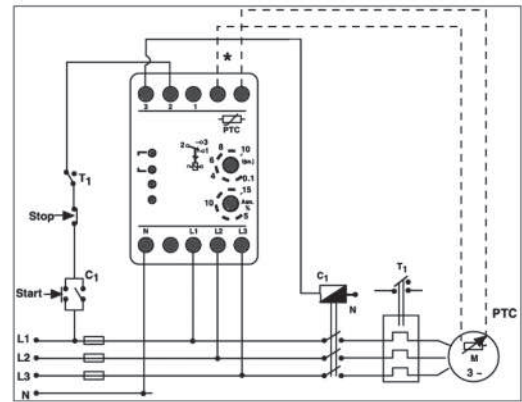

Figure 20 - Thermistor - relay connection

Motor Protection via PTC and Thermistor

Resistance of PTC temperature sensors that are placed inside the winding, varies depending on the temperature. Ends of the PTC's have to be connected to Thermistor relay as illustrated in Figure 20. They halt the motor if the temperature of winding exceeds the limit. The resistance of PTC increases after the nominal temperature and stops the motor by switching off the circuit.

Miksan Motor A.S. electric motors have F class isolation that allows a raise of 105 °C in winding temperature at maximum ambient temperature of the 40 °C.

Placement of terminal box is defined according to EN 12157 standard and all pumps of Miksan Motor are manufactured in default position as in number 2. Also other terminal box positions can be provided on request.

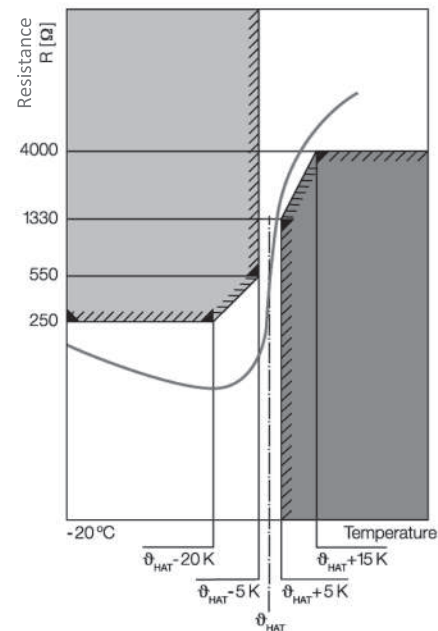

Figure 21 - Resistance - temperature Curve for used PTC

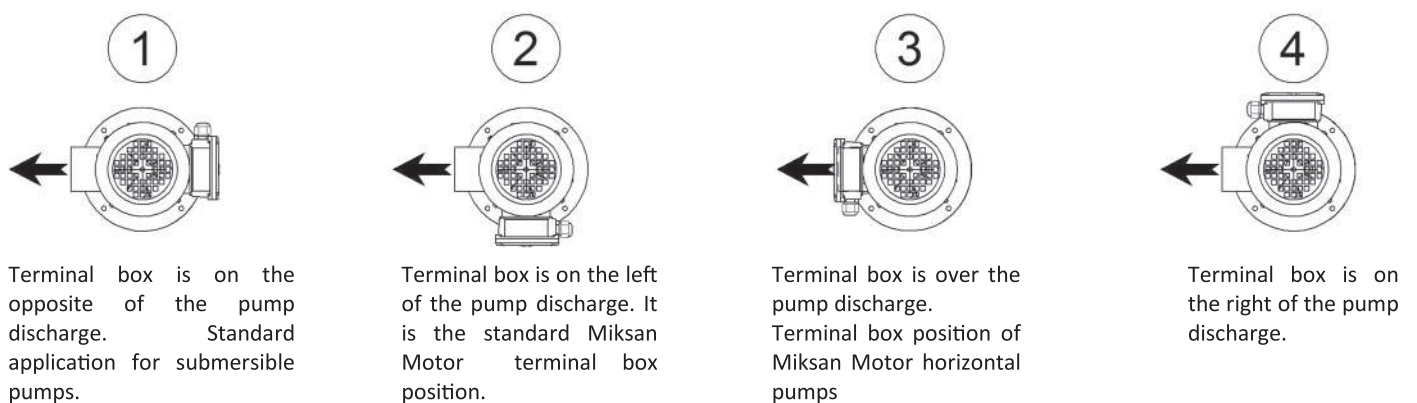

Figure 22 - Terminal box positions according to EN 12157

Special Connections

There are some improvements in electrical connections of the coolant pumps used in machine tools according to EN ISO 23570-3:2009.

Electricity can be provided to motor via multi-pin connector on the terminal box according to the standard mentioned above. Also connection of the pins is described in the standards.

Our pumps provide the connector coupled with motor on request.

Male pin connector is assembled on motor and connection of the pin ends is shown in figure below.

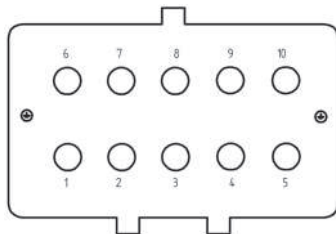

Figure 23 - Male Connector Pin Ends

Socket	Motor
1	U1
2	V1
3	W1
6	W2
7	U2
8	V2

Pins of 4, 5, 9, and 10 are left empty for thermistor or motor brake. Star or delta connections are done by female connector. If motor is star connected, 6, 7, 8 pins are bridged, else if motor is delta connected, 1-6, 2-7, 3-8 pins are bridged.

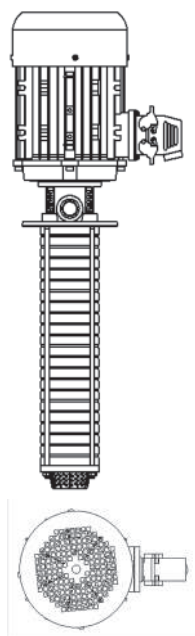

Figure 24 - Connector and Pump Assembly



AP PUMP

Applications:

- Cutting, turning, milling, boring, grinding and similar applications of the machine tools,
- Band sawing machines,
- Ceramic cutting machines,
- Glass cutting and optical machines,
- Circulation systems. AP Pumps are used for pumping of cutting / cooling fluids.

On demand, AP Pumps can be supplied with inlet strainer.

Fluid Specifications:

- Coolants,
- Cutting oils,
- Grinding oils,
- Water,
- Chemical liquids
- Fluid temperature 0...60 °C
- Kinematic viscosity 1...30 mm²/s

Materials:

Pump body	: PP
Volute	: PP
Impeller	: PP
Pump Shaft	: Engineering steel - AISI 1040 (DIN C35) Stainless steel - AISI 316 (DIN 4401) (Optional) Stainless steel - AISI 420(DIN X20Cr13) (Optional)
Strainer	: PE (Optional)
Electric motor	: 3 phase induction motor 1 phase induction motor (Optional) 2 pole Protection degree IP 54

DIMENSIONS & NOMINAL VALUES

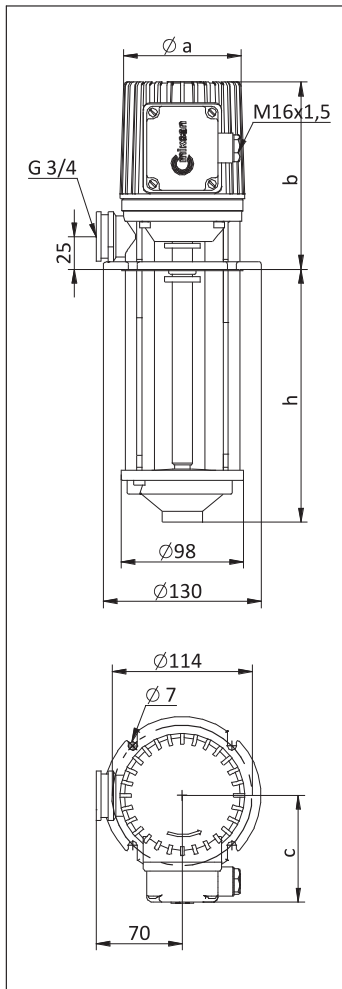

TYPE	Depth of immersion h (mm)	mm			Weight kg	Power kW	Voltage V(Δ /Y)	Frequency Hz	Rated current	
		a	b	c					A	rpm
AP/11	110	96	152	83	2.80	0.09	230/400	50	0.48/0.28	2830
AP/16	160				2.83					
AP/21	210				2.85					

- * Pump dimensions according to EN 12157.
- ** The performance curves are based on 1 mm²/s (cSt) kinematic viscosity values and 997 kg/m³ density
- *** Curve tolerance according to ISO 9906:2012 Grade 3B .

Performance Curve

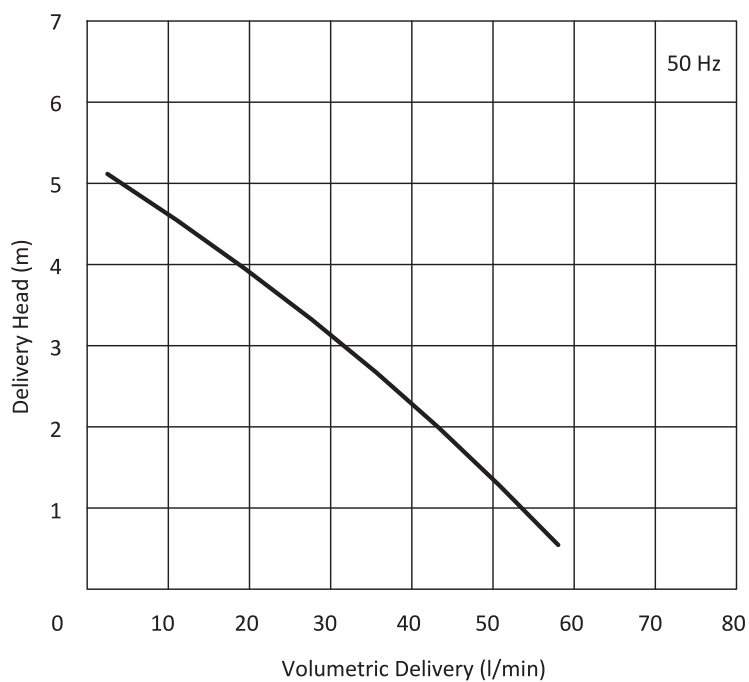



BP PUMP

Applications:

- Cutting, turning, milling, boring, grinding and similar applications of the machine tools,
- Band sawing machines,
- Circulation systems. BP Pumps are used for pumping of cutting / cooling fluids.

On demand, BP Pumps can be supplied with inlet strainer.

Fluid Specifications:

- Coolants,
- Cutting oils,
- Grinding oils,
- Fluid temperature 0...60 °C
- Kinematic viscosity 1...45 mm²/s

Materials:

Pump body	: Aluminium
Volute	: Aluminium
Impeller	: Aluminium
Shaft	: Engineering steel - AISI 1040 (DIN C35) ,
Strainer	: PE (Optional)
Electric motor	: 3 phase induction motor 1 phase induction motor (Optional) 2 pole Protection degree IP 54

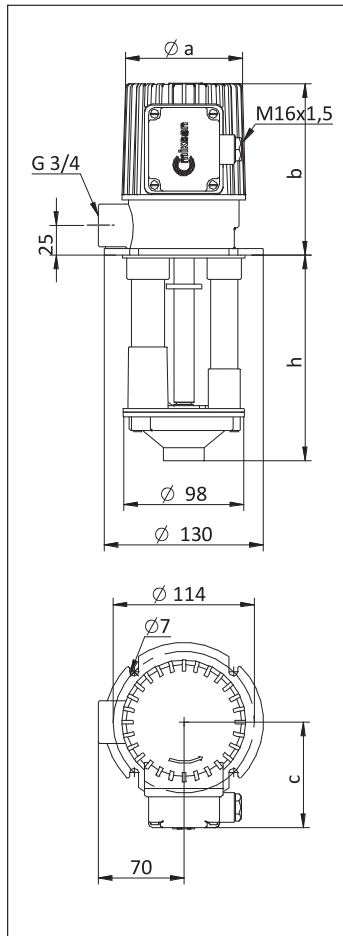

DIMENSIONS & NOMINAL VALUES

TYPE	Depth of immersion h (mm)	a	b	c	Weight kg	Power kW	Voltage V(ΔY)	Frequency Hz	Rated current A	Speed rpm
		mm								
BP/12	120	96	140	83	3.2	0.09	230/400	50	0.48/0.28	2830
BP/17	170				3.4					
BP/22	220				3.5					
BP/27	270				3.9					
BP/35	350				4.3					

- * Pump dimensions according to EN 12157.
- ** The performance curves are based on 1 mm²/s (cSt) kinematic viscosity values and 997 kg/m³ density
- *** Curve tolerance according to ISO 9906:2012 Grade 3B .

Performance Curve

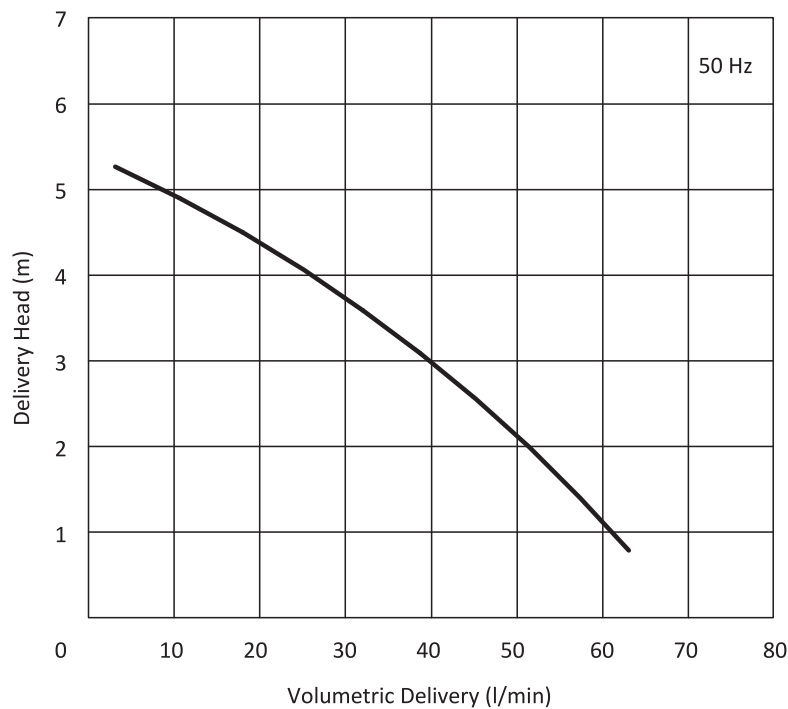



CP PUMP

Applications:

- Cutting, turning, milling, boring, grinding and similar applications of the machine tools,
- Band sawing machines,
- Circulation systems. CP Pumps are used for pumping of cutting / cooling fluids.

Fluid Specifications:

- Coolants,
- Cutting oils,
- Grinding oils,
- Water,
- Chip contains liquids (max. 6mm)
- Fluid temperature 0...60 °C
- Kinematic viscosity 1...90 mm²/s

Materials:

Pump body	: Cast iron - DIN GG 25
Volute	: PP Cast iron - DIN GG 25 (Optional only for CP1 series)
Impeller	: PP Brass (Optional only for CP1 series)
Pump shaft	: Engineering steel - AISI 1040 (DIN C35) Stainless steel- AISI 420(DIN X20Cr13) (Optional)
Electric motor	: 3 phase induction motor 1 phase induction motor (Optional) 2 pole Protection degree IP 54

DIMENSIONS & NOMINAL VALUES

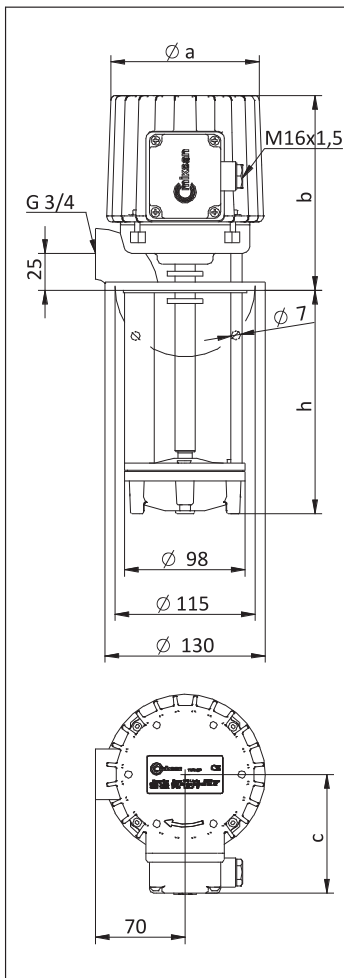

TYPE	Depth of immersion h (mm)	mm			Weight kg	Power kW	Voltage V(Δ/Y)	Frequency Hz	Rated current A	Speed rpm
		a	b	c						
CP 112	130	127	158	95	6.6	0.25	230/400	50	1.26/0.73	2760
CP 117	180				7.1					
CP 122	230				7.4					
CP 127	280				7.9					
CP 135	350				8.4					
CP 212	130	127	158	95	6.6	0.25	230/400	50	1.26/0.73	2760
CP 217	180				7.1					
CP 222	230				7.4					
CP 227	280				7.9					
CP 235	350				8.4					

- * Pump dimensions according to EN 12157.
- ** The performance curves are based on 1 mm²/s (cSt) kinematic viscosity values and 997 kg/m³ density
- *** Curve tolerance according to ISO 9906:2012 Grade 3B .

Performance Curve

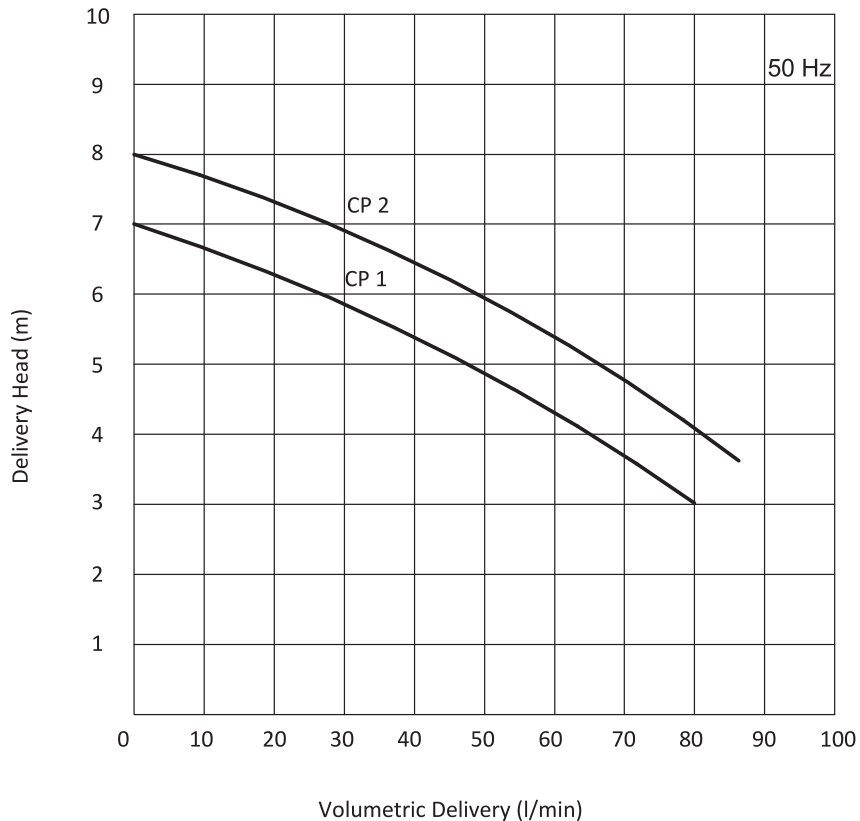



EP 150 PUMP

Applications:

- Cutting, turning, milling, boring, grinding and similar applications of the machine tools,
- Filtration systems,
- Circulation systems. EP Pumps are used for pumping of cutting / cooling fluids.

Fluid Specifications:

- Coolants,
- Cutting oils,
- Grinding oils,
- Water,
- Chip contains liquids (max. 8mm)
- Fluid temperature 0...80 °C
- Kinematic viscosity 1...90 mm²/s

Materials:

Pump body	: Cast iron - DIN GG 25
Volute	: Cast iron - DIN GG 25
Impeller	: Investment casting steel - AISI 4140 (DIN 42CrMo4)
Pump shaft	: Engineering steel - AISI 1040 (DIN C35)
Electric motor	: 3 phase induction motor, 2-Pole Protection degree IP 55

DIMENSIONS & NOMINAL VALUES

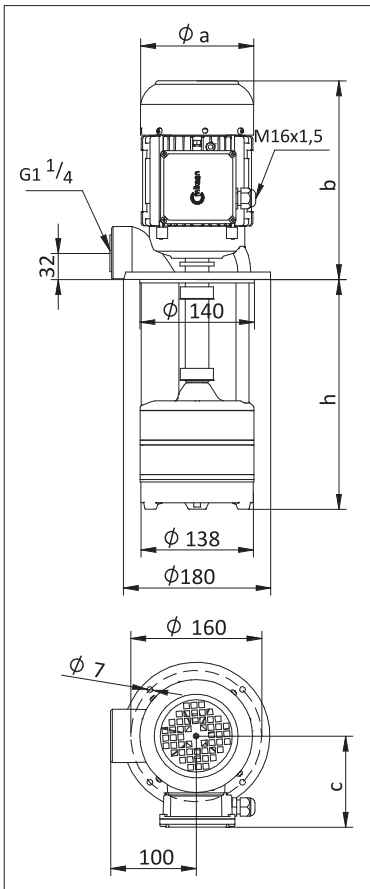

TYPE	Depth of immersion h (mm)	a	b	c	Weight kg	Power kW	Voltage V(Δ/Y)	Frequency Hz	Rated current A	Speed rpm
		mm								
EP 150/200	200	138	242	111	15.2	0.37	230/400	50	1.84/1.05	2790
EP 150/270	270				16.3					
EP 150/350	350				16.8					
EP 150/440	440				18.5					
EP 150/550	550				19.5					
EP 152/240	240	138	242	111	18.8	1.1*	230/400	50	4.85/2.8	2720
EP 152/310	310				19.4					
EP 152/390	390				20.2					
EP 152/480	480				23.7					
EP 153/280	280	138	242	111	21.7	1.1*	230/400	50	4.85/2.8	2720
EP 153/350	350				22.3					
EP 153/430	430				23.1					
EP 153/520	520				26.6					

* EP 152 and EP 153 pumps have IE2 motors. These pumps are excluded from efficiency class since their motors are completely integrated into the pump according to IEC 60034-30-1:2014 standard .

** Pump dimensions according to EN 12157.

*** The performance curves are based on 1 mm²/s (cSt) kinematic viscosity values and 997 kg/m³ density

**** Curve tolerance according to ISO 9906:2012 Grade 3B .

Performance Curve

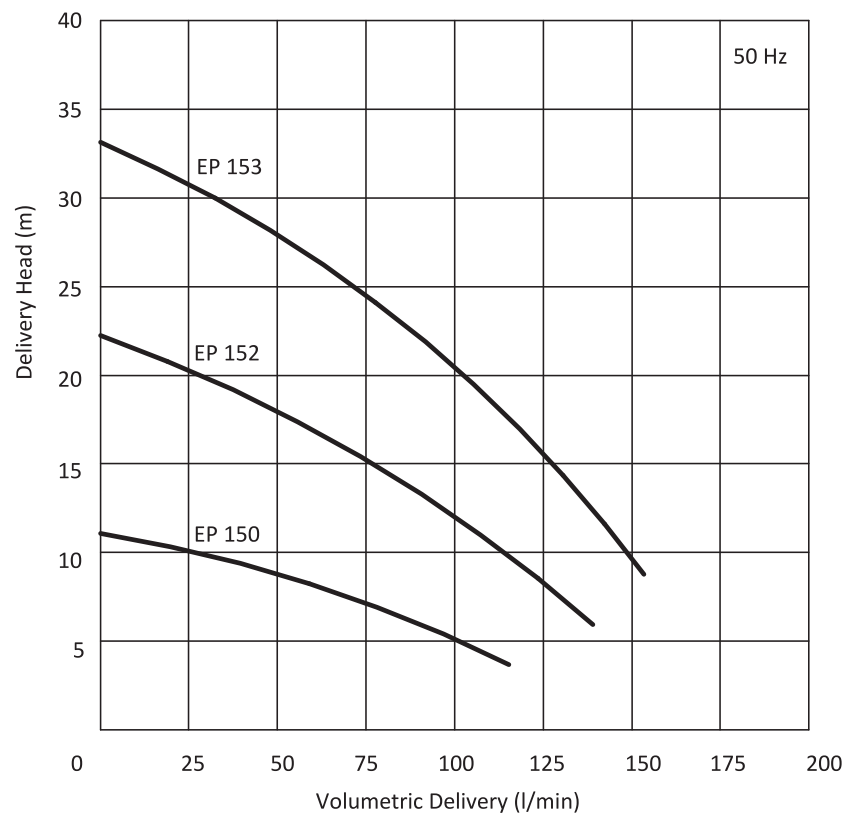



EP 250 PUMP

Applications:

- Cutting, turning, milling, boring, grinding and similar applications of the machine tools,
- Filtration systems,
- Circulation systems. EP Pumps are used for pumping of cutting / cooling fluids.

Fluid Specifications:

- Coolants,
- Cutting oils,
- Grinding oils,
- Water,
- Chip contains liquids (max. 8mm)
- Fluid temperature 0...80 °C
- Kinematic viscosity 1...90 mm²/s

Materials:

Pump body	: Cast iron - DIN GG 25
Volute	: Cast iron - DIN GG 25
Impeller	: Investment casting steel - AISI 4140 (DIN 42CrMo4)
Pump shaft	: Engineering steel - AISI 1040 (DIN C35)
Electric motor	: 3 phase induction motor, 2-Pole Protection degree IP 55

DIMENSIONS & NOMINAL VALUES

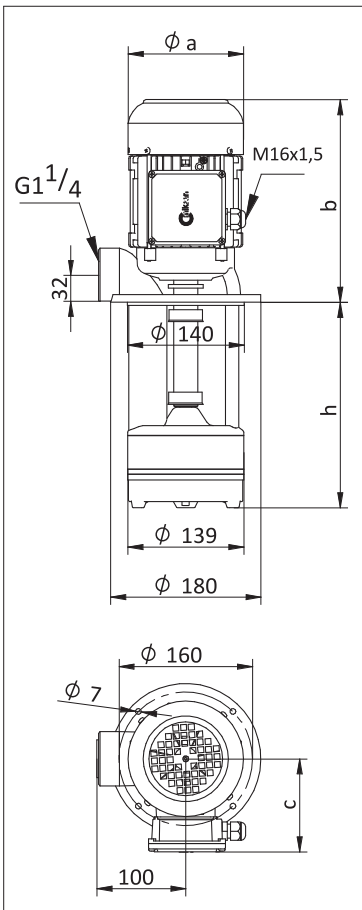

TYPE	Depth of immersion h (mm)	mm			Weight kg	Power kW	Voltage V(ΔY)	Frequency Hz	Rated current A	Speed rpm
		a	b	c						
EP 250/200	200	138	242	111	15.8	0.55	230/400	50	2.25/1.3	2780
EP 250/270	270				16.9					
EP 250/350	350				17.4					
EP 250/440	440				19.1					
EP 250/550	550				20.1					
EP 252/250	250	138	242	111	20.5	1.1*	230/400	50	4.85/2.8	2780
EP 252/320	320				21.0					
EP 252/400	400				22.0					
EP 252/490	490				23.5					
EP 253/300	300	176	309	139	27.0	1.5	230/400	50	5.72/3.3	2910
EP 253/370	370				27.5					
EP 253/450	450				28.0					

* EP 252 pump has IE2 motor. These pumps are excluded from efficiency class since their motors are completely integrated into the pump according to IEC 60034-30-1:2014 standard.

** Pump dimensions according to EN 12157.

*** The performance curves are based on 1 mm²/s (cSt) kinematic viscosity values and 997 kg/m³ density

**** Curve tolerance according to ISO 9906:2012 Grade 3B.

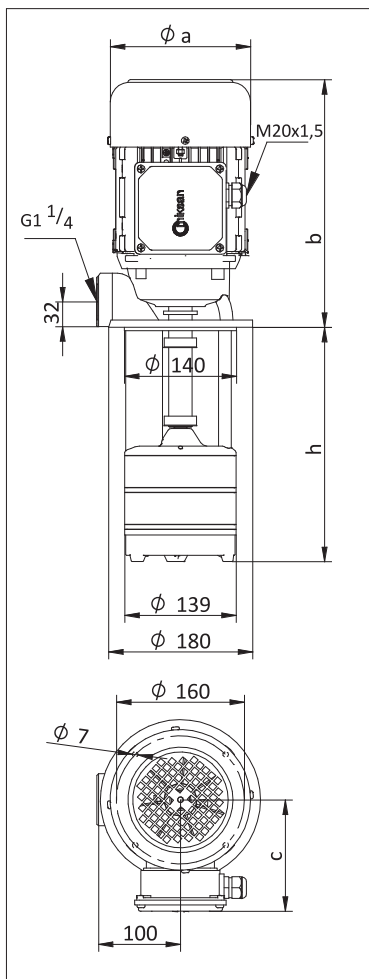

Performance Curve

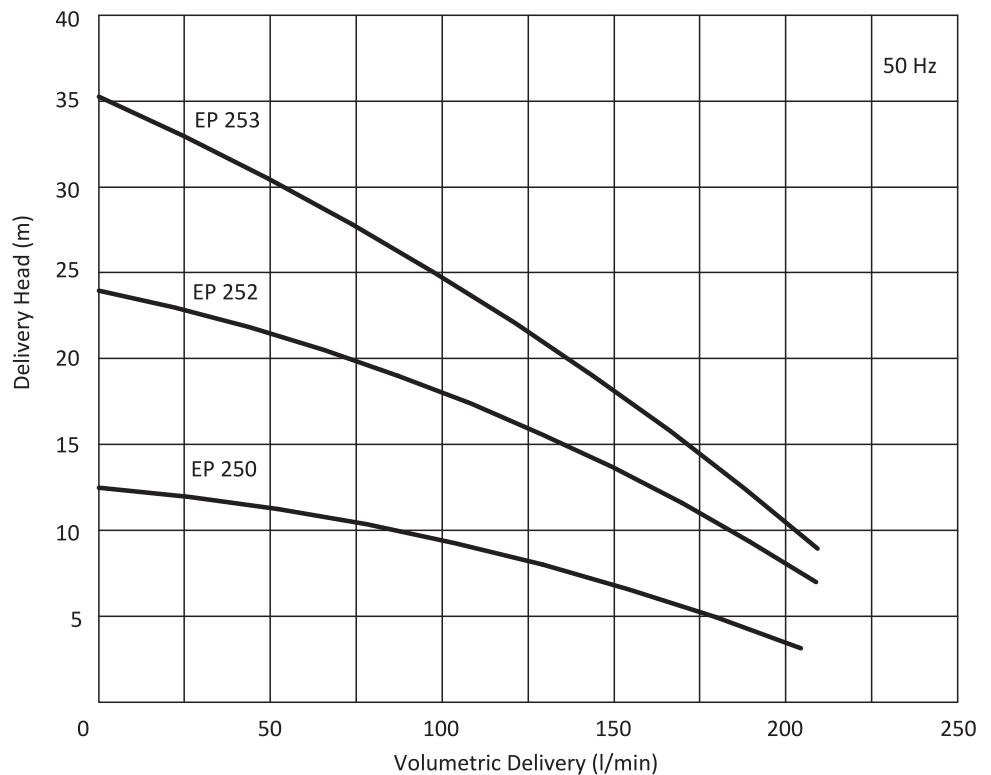



EP 350 PUMP

Applications:

- Cutting, turning, milling, boring, grinding and similar applications of the machine tools,
- Filtration systems,
- Circulation systems. EP Pumps are used for pumping of cutting / cooling fluids.

Fluid Specifications:

- Coolants,
- Cutting oils,
- Grinding oils,
- Water,
- Chip contains liquids (max. 8mm)
- Fluid temperature 0...80 °C
- Kinematic viscosity 1...90 mm²/s

Materials:

Pump body	: Cast iron - DIN GG 25
Volute	: Cast iron - DIN GG 25
Impeller	: Investment casting steel - AISI 4140 (DIN 42CrMo4)
Pump shaft	: Engineering steel - AISI 1040 (DIN C35)
Electric motor	: 3 phase induction motor 2 pole, 2900 rpm Protection degree IP 55

DIMENSIONS & NOMINAL VALUES

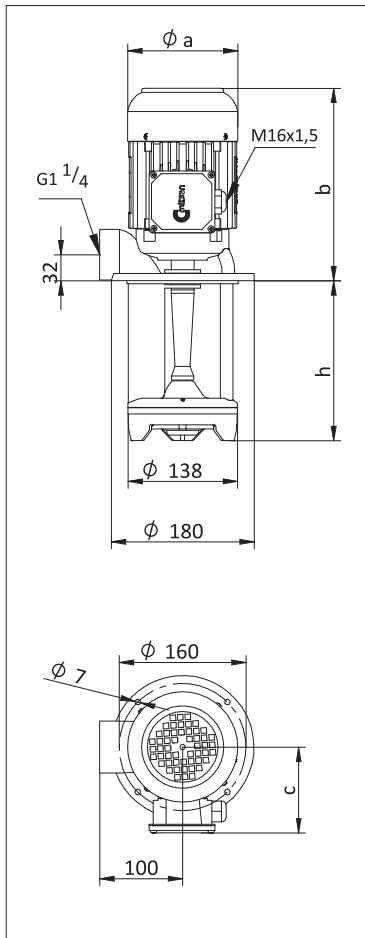

TYPE	Depth of immersion h (mm)	a	b	c	Weight kg	Power kW	Voltage V(ΔY)	Frequency Hz	Rated current A	Speed rpm
		mm								
EP 350/200	200	138	242	111	16.5	0.75	230/400	50	3.12/1.8	2820
EP 350/270	270				17.7					
EP 350/350	350				18.0					
EP 350/440	440				19.7					
EP 350/550	550				20.7					

- * Pump dimensions according to EN 12157.
- ** The performance curves are based on $1 \text{ mm}^2/\text{s}$ (cSt) kinematic viscosity values and 997 kg/m^3 density
- *** Curve tolerance according to ISO 9906:2012 Grade 3B .

Performance Curve

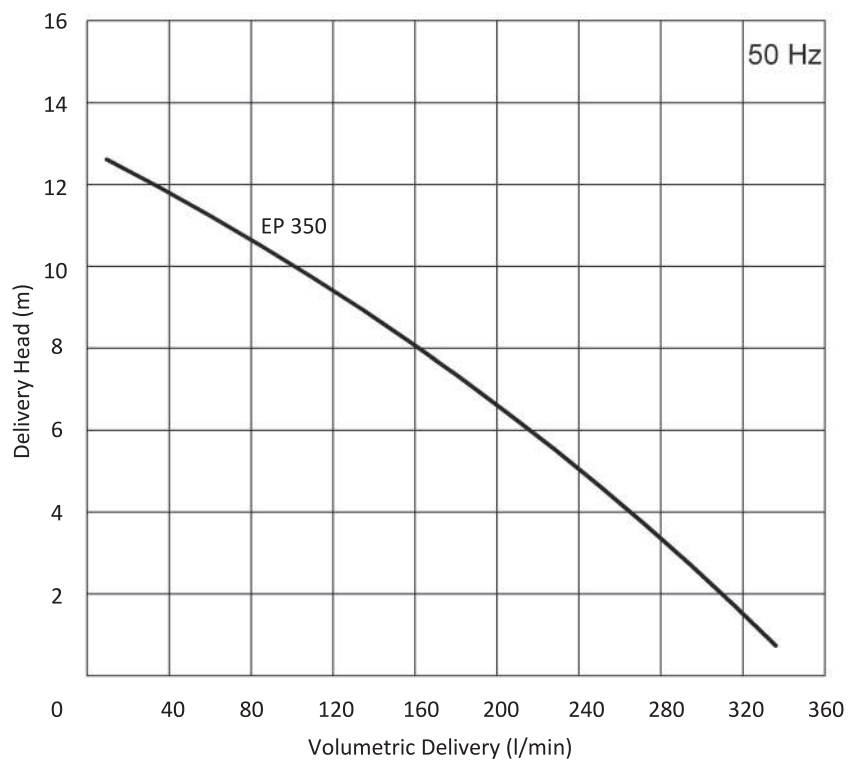



EPV 250 PUMP

Applications:

- Vortex type pump is used for pumping liquids which contains metal chips,
- Cutting, turning, milling, boring, grinding and similar applications of the machine tools,
- Filtration systems,
- Circulation systems. EPV Pumps are used for pumping of cutting / cooling fluids.

Fluid Specifications:

- Coolants,
- Cutting oils,
- Grinding oils,
- Water,
- Chip contains liquids (max. 12mm)
- Fluid temperature 0...80 °C
- Kinematic viscosity 1...45 mm²/s

Materials:

Pump body	: Cast iron - DIN GG 25
Volute	: Cast iron - DIN GG 25
Impeller	: Investment casting steel - AISI 4140 (DIN 42CrMo4)
Pump shaft	: Engineering steel - AISI 1040 (DIN C35)
Electric motor	: 3 phase induction motor 2 pole, 2900 rpm Protection degree IP 55

DIMENSIONS & NOMINAL VALUES

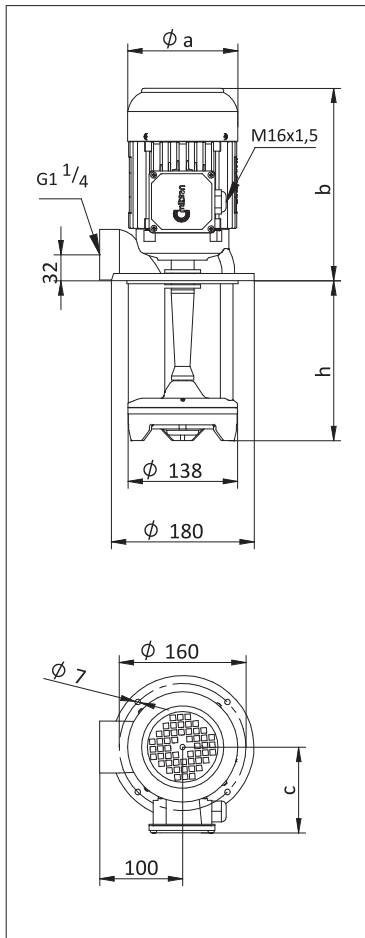

TYPE	Depth of immersion h (mm)	a	b	c	Weight kg	Power kW	Voltage V(ΔY)	Frequency Hz	Rated current A	Speed rpm
		mm								
EPV 250/210	210	138	242	111	16.4	0.55	230/400	50	2.25/1.3	2780
EPV 250/280	280				17.6					
EPV 250/360	360				17.9					
EPV 250/450	450				19.6					
EPV 250/560	560				20.6					

- * Pump dimensions according to EN 12157.
- ** The performance curves are based on $1\text{ mm}^2/\text{s}$ (cSt) kinematic viscosity values and 997 kg/m^3 density
- *** Curve tolerance according to ISO 9906:2012 Grade 3B .

Performance Curve

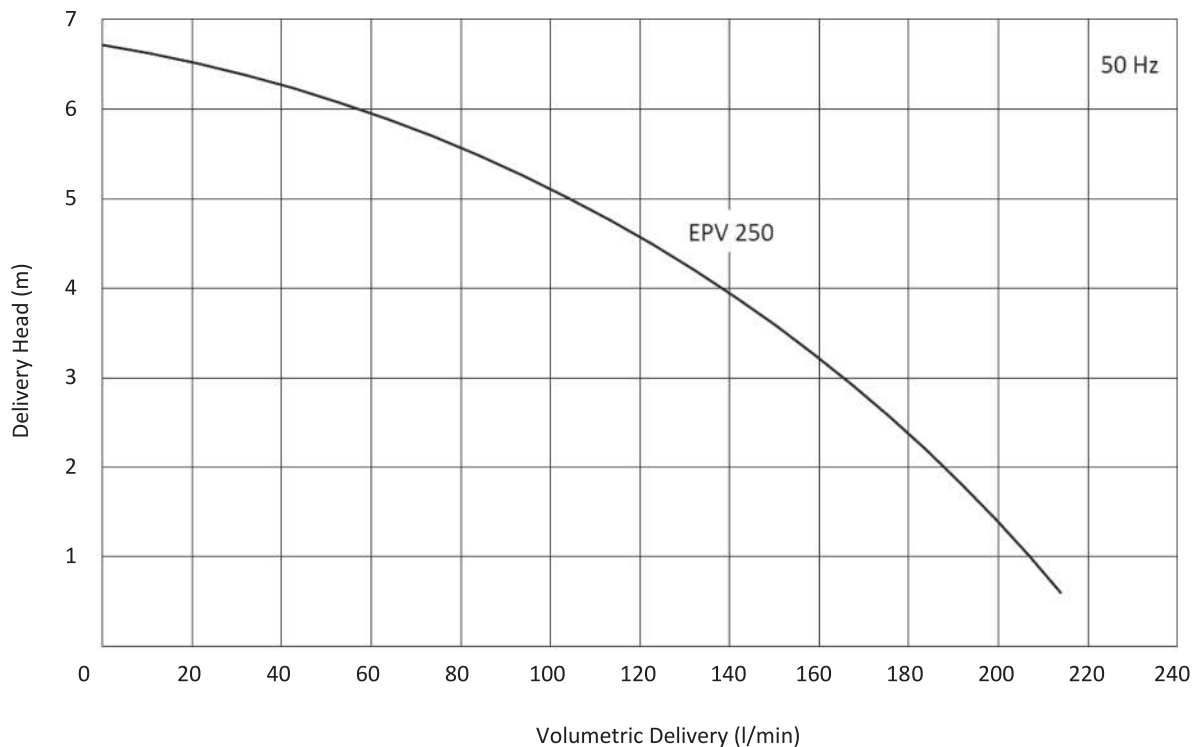



GP PUMP

Performance Curve

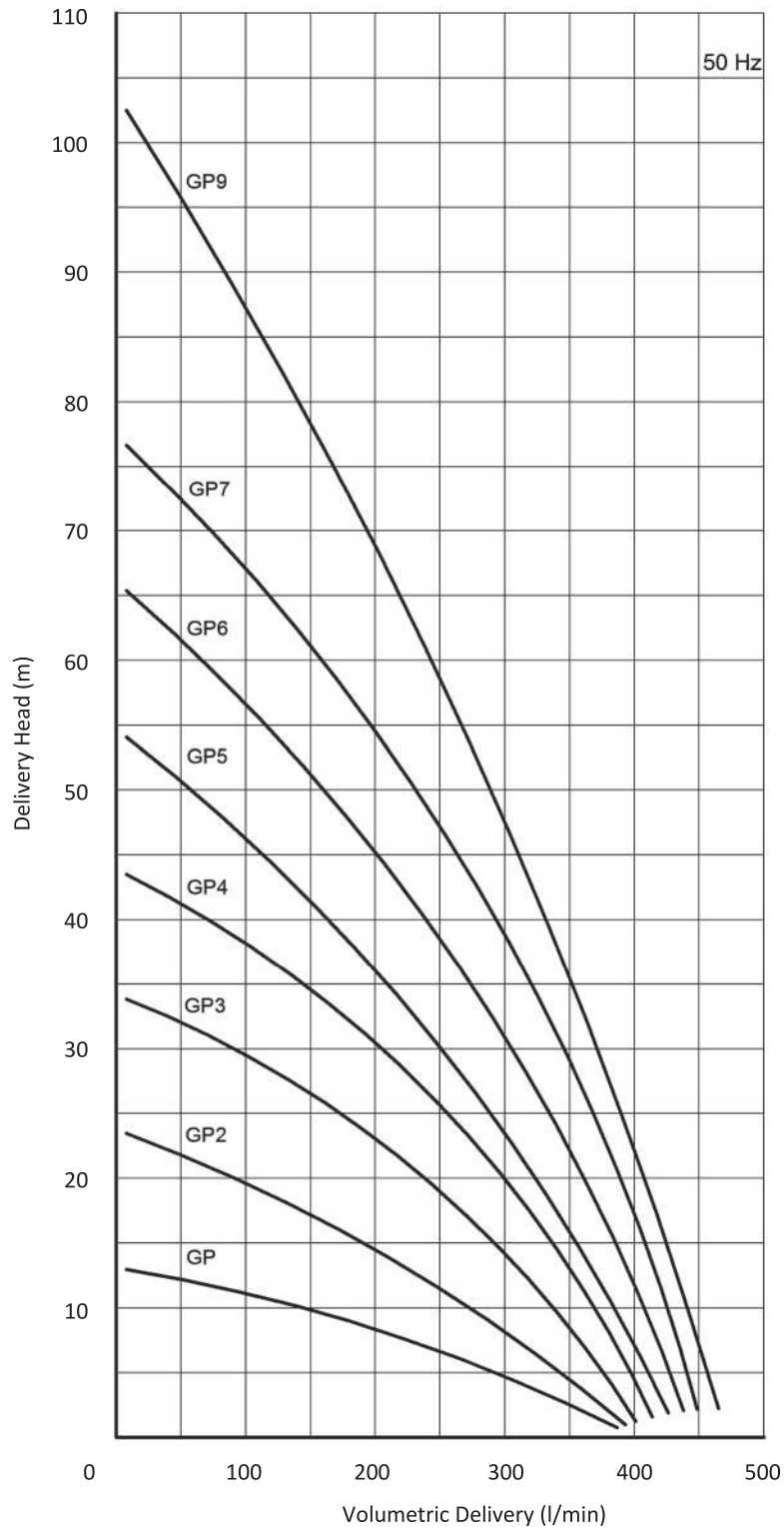

Applications:

- Machine tools especially on grinding operations,
- Cutting, turning, milling, boring applications,
- Filtration systems,
- Circulation systems. GP Pumps are used for pumping of cutting / cooling fluids.

DIMENSIONS & NOMINAL VALUES

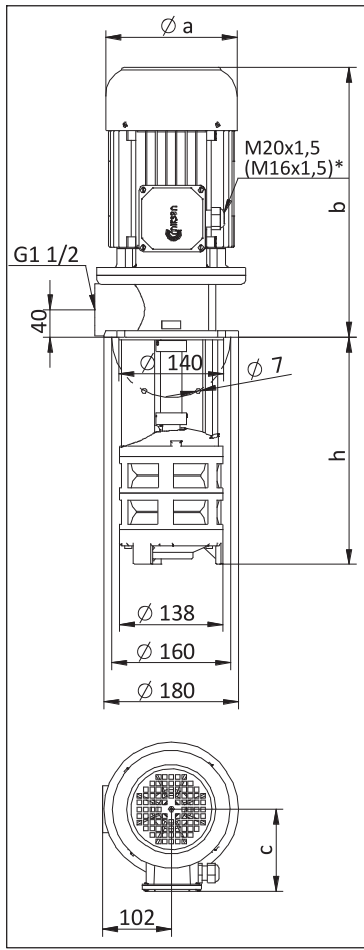

TYPE	Depth of immersion h (mm)	a b c			Weight kg	Power kW	Voltage V(ΔY)	Frequency Hz	Rated current A	Speed rpm
		mm	mm	mm						
GP /200	200	157	319	118	23.5	1.1	230/400	50	4.16/2.4	2890
GP /270	270				25.0					
GP /350	350				26.0					
GP /440	440				27.5					
GP /550	550				29.5					
GP -2/190	190	176	338	139	30.0	1.5	230/400	50	5.72/3.3	2910
GP -2/250	250				30.5					
GP -2/320	320				32.0					
GP -2/400	400				33.0					
GP -2/490	490				34.5					
GP -2/600	600				36.5					
GP -3/240	240	176	363	139	36.0	2.2	230/400	50	7.79/4.5	2905
GP -3/300	300				36.5					
GP -3/370	370				37.5					
GP -3/450	450				39.0					
GP -3/540	540				40.5					
GP -3/650	650				42.0					
GP -4/290	290	176	363	139	39.0	2.2	230/400	50	7.79/4.5	2905
GP -4/350	350				39.5					
GP -4/420	420				40.5					
GP -4/500	500				42.0					
GP -4/590	590				43.5					
GP -4/700	700				45.0					
GP -5/340	340	194	398	150	48.0	3.0	230/400	50	10.39/6.0	2905
GP -5/400	400				48.5					
GP -5/470	470				50.0					
GP -5/550	550				51.0					
GP -5/640	640				52.5					
GP -5/750	750				54.5					
GP -6/390	390	194	398	150	54.0	4.0	230/400	50	13.68/7.9	2900
GP -6/450	450				54.5					
GP -6/520	520				56.0					
GP -6/600	600				57.0					
GP -6/690	690				58.5					
GP -7/440	440	218	412	163	61.5	5.5	230/400	50	17.15/9.9	2900
GP -7/500	500				62.0					
GP -7/570	570				63.0					
GP -7/650	650				64.5					
GP -7/740	740				66.0					
GP -9/540	520	218	412	163	67.5	5.5	230/400	50	17.15/9.9	2900
GP -9/600	600				68.0					
GP -9/670	670				69.0					
GP -9/750	750				70.5					

* M16x1,5 cable gland is used on GP 1 pump.
 ** Pump dimensions according to EN 12157.
 *** The performance curves are based on 1 mm²/s (cSt) kinematic viscosity values and 997 kg/m³ density
 **** Curve tolerance according to ISO 9906:2012 Grade 3B.

Fluid Specifications:

- Coolants,
- Cutting oils,
- Grinding oils,
- Water,
- Chip contains liquids (max. 8mm)
- Fluid temperature 0...80 °C
- Kinematic viscosity 1...90 mm²/s

Materials:

- Pump body : Cast iron - DIN GG 25
- Volute : Cast iron - DIN GG 25
- Impeller : Brass
- Pump shaft : Engineering steel - AISI 1040 (DIN C35)
- Electric motor : 3 phase induction motor IE3 - 2 pole
Protection degree IP 55

GPA/GPF PUMP

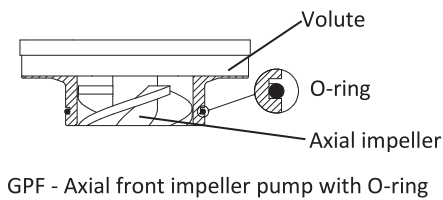
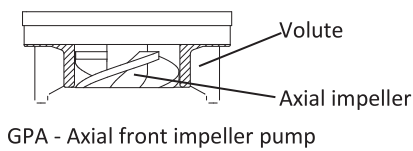

Performance Curve

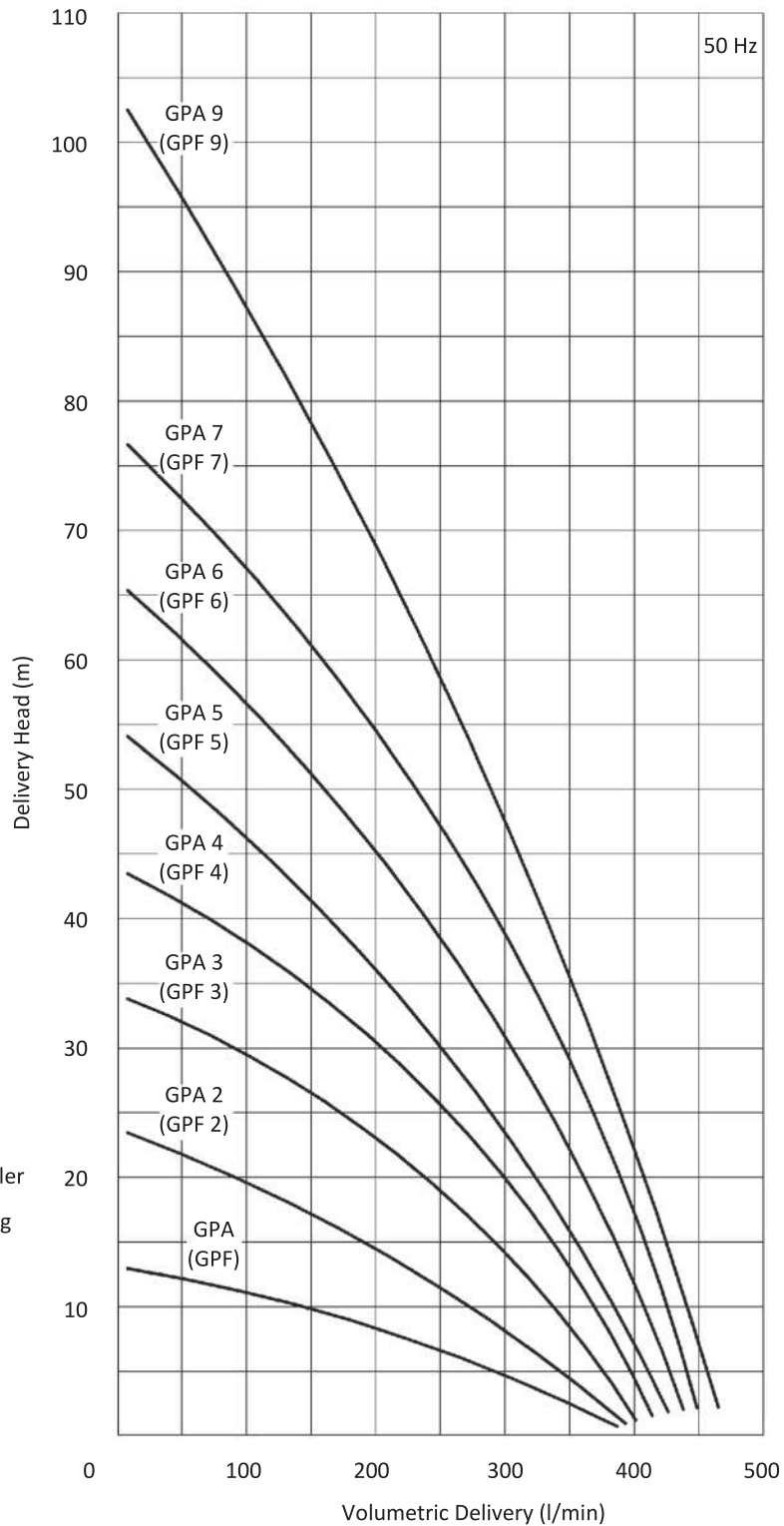

GPA PUMP

Applications:

- GPA pump has an additional axial impeller,
- It is used for pumping the liquid foam resulting from high-speed machining operations,
- Pumping metal chips together with the fluid by mixing,
- Filtration systems,
- Hot liquid applications,
- GPA Pumps are used for pumping of cutting / cooling fluids in circulation systems.

Fluid Specifications:

- Coolants,
- Cutting oils,
- Grinding oils,
- Water,
- Fluid temperature 0...80 °C
- Kinematic viscosity 1...90 mm²/s

DIMENSIONS & NOMINAL VALUES

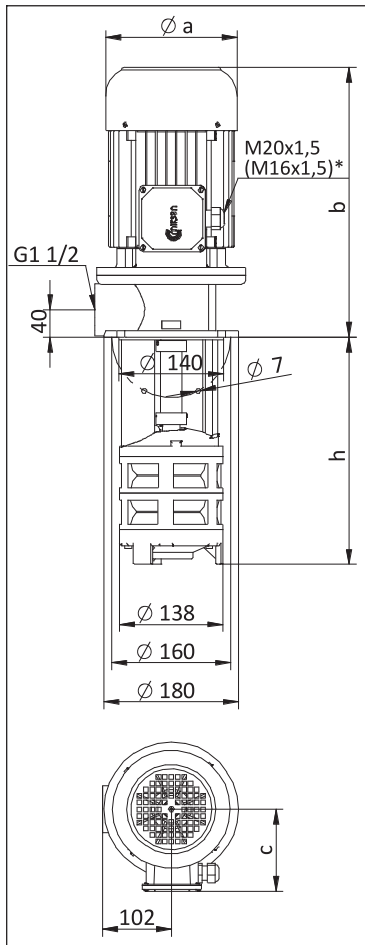

* M16x1,5 cable gland is used on GPA(F) 1 pump.

** Pump dimensions according to EN 12157.

*** The performance curves are based on 1 mm²/s (cSt) kinematic viscosity values and 997 kg/m³ density

**** Curve tolerance according to ISO 9906:2012 Grade 3B.

TYPE	Depth of immersion h (mm)	mm			Weight kg	Power kW	Voltage V(ΔY)	Frequency Hz	Rated current A	Speed rpm
		a	b	c						
GPA(F) /200	200	157	319	118	24.0	1.1	230/400	50	4.16/2.4	2890
GPA(F) /270	270				25.5					
GPA(F) /350	350				26.5					
GPA(F) /440	440				28.0					
GPA(F) /550	550				30.0					
GPA(F) -2/190	190	176	338	139	30.5	1.5	230/400	50	5.72/3.3	2910
GPA(F) -2/250	250				31.0					
GPA(F) -2/320	320				32.5					
GPA(F) -2/400	400				33.5					
GPA(F) -2/490	490				35.0					
GPA(F) -2/600	600				37.0					
GPA(F) -3/240	240	176	363	139	36.5	2.2	230/400	50	7.79/4.5	2905
GPA(F) -3/300	300				37.0					
GPA(F) -3/370	370				38.0					
GPA(F) -3/450	450				39.5					
GPA(F) -3/540	540				41.0					
GPA(F) -3/650	650				42.5					
GPA(F) -4/290	290	176	363	139	39.5	2.2	230/400	50	7.79/4.5	2905
GPA(F) -4/350	350				40.0					
GPA(F) -4/420	420				41.0					
GPA(F) -4/500	500				42.5					
GPA(F) -4/590	590				44.0					
GPA(F) -4/700	700				45.5					
GPA(F) -5/340	340	194	398	150	48.5	3.0	230/400	50	10.39/6.0	2905
GPA(F) -5/400	400				49.0					
GPA(F) -5/470	470				50.5					
GPA(F) -5/550	550				51.5					
GPA(F) -5/640	640				52.5					
GPA(F) -5/750	750				54.5					
GPA(F) -6/390	390	194	398	150	54.5	4.0	230/400	50	13.68/7.9	2900
GPA(F) -6/450	450				55.0					
GPA(F) -6/520	520				56.5					
GPA(F) -6/600	600				57.5					
GPA(F) -6/690	690				59.0					
GPA(F) -7/440	440	218	412	163	62.0	5.5	230/400	50	17.15/9.9	2900
GPA(F) -7/500	500				62.5					
GPA(F) -7/570	570				63.5					
GPA(F) -7/650	650				65.0					
GPA(F) -7/740	740				66.5					
GPA(F) -9/540	520	218	412	163	68.0	5.5	230/400	50	17.15/9.9	2900
GPA(F) -9/600	600				68.5					
GPA(F) -9/670	670				69.5					
GPA(F) -9/750	750				71.0					

GPF PUMP

Applications:

- GPF pumps are used for pumping of liquid from vacuum zone on filtration systems. The pump works at vacuum zone, therefore it has an O-ring at the pump inlet. It also has an additional axial front impeller.

Fluid Specifications:

- Coolants,
- Cutting oils,
- Grinding oils,
- Water,
- Fluid temperature 0...80 °C
- Kinematic viscosity 1...90 mm²/s

Materials:

Pump body	: Cast iron - DIN GG 25
Volute	: Cast iron - DIN GG 25
Impeller	: Brass
Axial (front) impeller	: Investment casting steel - AISI 4140 (DIN 42CrMo4)
O-ring	: Viton
Pump shaft	: Engineering steel - AISI 1040 (DIN C35)
Electric motor	: 3 phase induction motor IE3 - 2 pole Protection degree IP 55

GPH PUMP

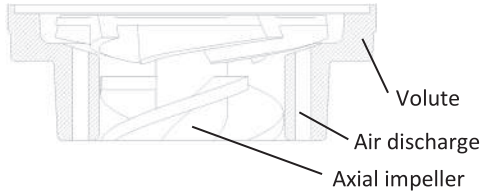

GPH - Axial front impeller with air release

Performance Curve

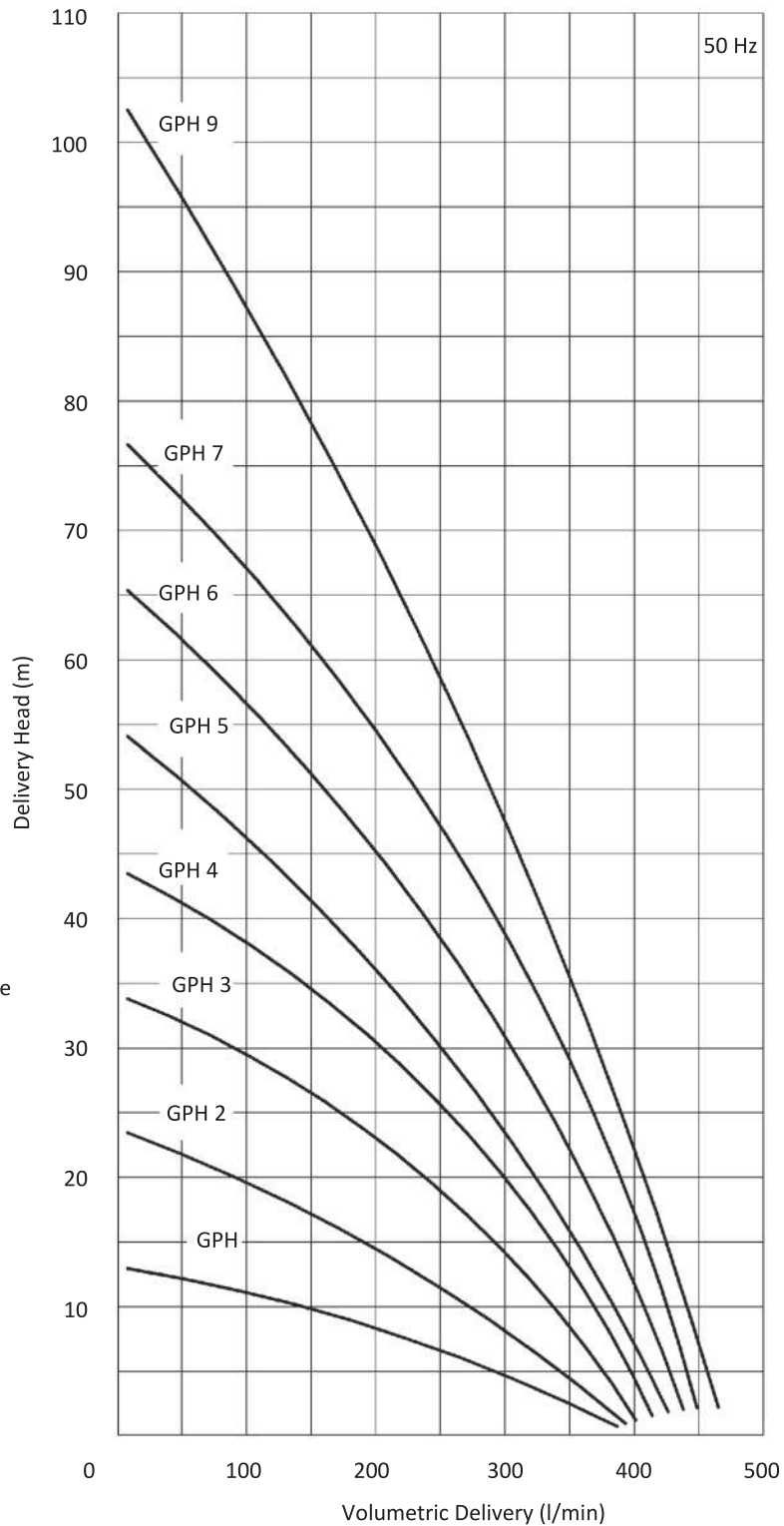

GPH PUMP

Applications:

- GPH pump has an additional axial impeller,
- It is used for pumping the liquid foam resulting from high-speed machining operations,
- Pumping metal chips together with the fluid by mixing,
- Filtration systems,
- Hot liquid applications,
- GPH Pumps are used for pumping of cutting / cooling fluids in circulation systems.

Fluid Specifications:

- Coolants,
- Cutting oils,
- Grinding oils,
- Water,
- Fluid temperature 0...80 °C
- Kinematic viscosity 1...90 mm²/s

DIMENSIONS & NOMINAL VALUES

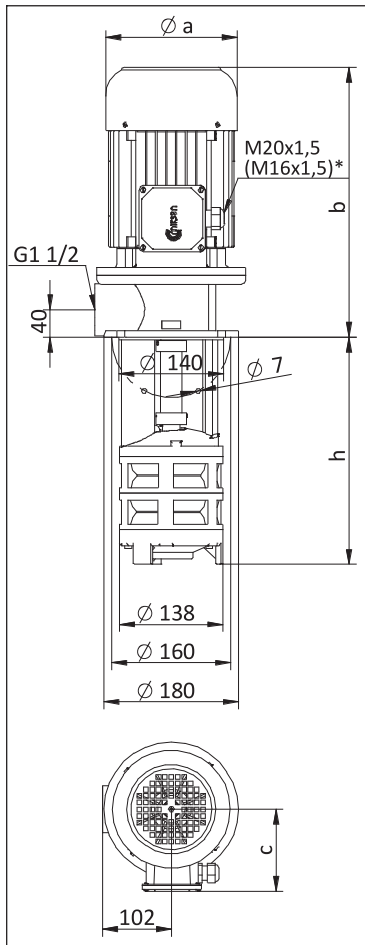

TYPE	Depth of immersion h (mm)	mm			Weight kg	Power kW	Voltage V(Δ/Y)	Frequency Hz	Rated current A	Speed rpm
		a	b	c						
GPH /200	200	157	319	118	24.0	1.1	230/400	50	4.16/2.4	2890
GPH /270	270				25.5					
GPH /350	350				26.5					
GPH /440	440				28.0					
GPH /550	550				30.0					
GPH -2/190	190	176	338	139	30.5	1.5	230/400	50	5.72/3.3	2910
GPH -2/250	250				31.0					
GPH -2/320	320				32.5					
GPH -2/400	400				33.5					
GPH -2/490	490				35.0					
GPH -2/600	600				37.0					
GPH -3/240	240	176	363	139	36.5	2.2	230/400	50	7.79/4.5	2905
GPH -3/300	300				37.0					
GPH -3/370	370				38.0					
GPH -3/450	450				39.5					
GPH -3/540	540				41.0					
GPH -3/650	650				42.5					
GPH -4/290	290	176	363	139	39.5	2.2	230/400	50	7.79/4.5	2905
GPH -4/350	350				40.0					
GPH -4/420	420				41.0					
GPH -4/500	500				42.5					
GPH -4/590	590				44.0					
GPH -4/700	700				45.5					
GPH -5/340	340	194	398	150	48.5	3.0	230/400	50	10.39/6.0	2905
GPH -5/400	400				49.0					
GPH -5/470	470				50.5					
GPH -5/550	550				51.5					
GPH -5/640	640				52.5					
GPH -5/750	750				54.5					
GPH -6/390	390	194	398	150	54.5	4.0	230/400	50	13.68/7.9	2900
GPH -6/450	450				55.0					
GPH -6/520	520				56.5					
GPH -6/600	600				57.5					
GPH -6/690	690				59.0					
GPH -7/440	440	218	412	163	62.0	5.5	230/400	50	17.15/9.9	2900
GPH -7/500	500				62.5					
GPH -7/570	570				63.5					
GPH -7/650	650				65.0					
GPH -7/740	740				66.5					
GPH -9/540	520	218	412	163	68.0	5.5	230/400	50	17.15/9.9	2900
GPH -9/600	600				68.5					
GPH -9/670	670				69.5					
GPH -9/750	750				71.0					

* M16x1,5 cable gland is used on GPH 1 pump.
 ** Pump dimensions according to EN 12157.
 *** The performance curves are based on 1 mm²/s (cSt) kinematic viscosity values and 997 kg/m³ density
 **** Curve tolerance according to ISO 9906:2012 Grade 3B.

Materials:

Pump body : Cast iron - DIN GG 25
 Volute : Cast iron - DIN GG 25
 Impeller : Brass
 Axial (front) impeller : Investment casting steel - AISI 4140 (DIN 42CrMo4)
 O-ring : Viton
 Pump shaft : Engineering steel - AISI 1040 (DIN C35)
 Electric motor : 3 phase induction motor IE3 - 2 pole
 Protection degree IP 55

IP PUMP



Performance Curve

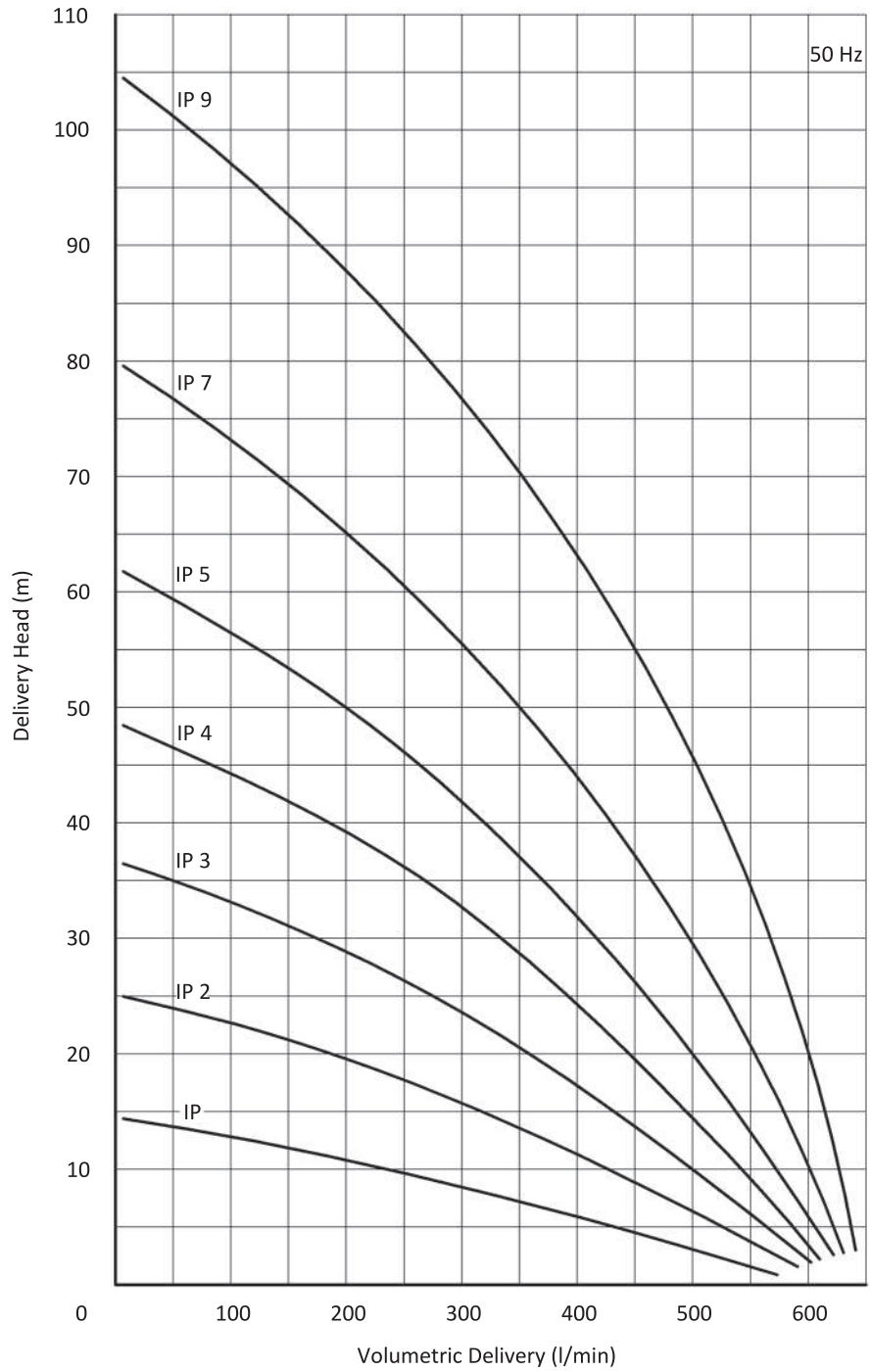

Applications:

- Machine tools especially on grinding operations,
- Cutting, turning, milling, boring applications,
- Filtration systems,
- Circulation systems. IP Pumps are used for pumping of cutting / cooling fluids.

DIMENSIONS & NOMINAL VALUES

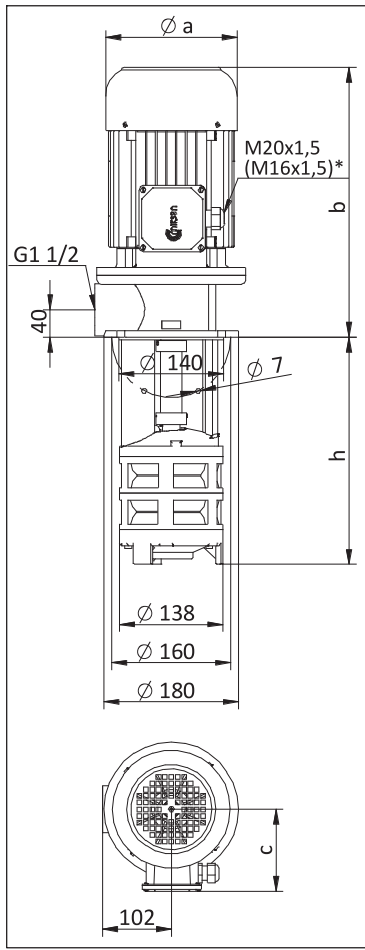

TYPE	Depth of immersion h (mm)	mm			Weight kg	Power kW	Voltage V(Δ/Y)	Frequency Hz	Rated current A	Speed rpm
		a	b	c						
IP/210	210	157	319	118	24.0	1.1	230/400	50	4.16/2.4	2890
IP/280	280				25.5					
IP/360	360				26.5					
IP/450	450				28.0					
IP/560	560				30.0					
IP-2/210	210	176	363	139	34.0	2.2	230/400	50	7.79/4.5	2905
IP-2/270	270				34.5					
IP-2/340	340				35.5					
IP-2/420	420				36.5					
IP-2/510	510				38.0					
IP-2/620	620				40.0					
IP-3/270	270	194	398	150	46.5	4.0	230/400	50	13.68/7.9	2900
IP-3/330	330				47.0					
IP-3/400	400				48.0					
IP-3/480	480				49.5					
IP-3/570	570				51.0					
IP-3/680	680				53.0					
IP-4/330	330	218	412	163	54.0	5.5	230/400	50	17.15/9.9	2900
IP-4/390	390				54.5					
IP-4/460	460				55.5					
IP-4/540	540				57.0					
IP-4/630	630				58.5					
IP-4/740	740				60.5					
IP-5/390	390	218	412	163	57.5	5.5	230/400	50	17.15/9.9	2900
IP-5/450	450				58.0					
IP-5/520	520				59.0					
IP-5/600	600				60.5					
IP-5/690	690				62.0					
IP-7/510	510	258	495	177	88.5	7.5	400Δ	50	14.0	2930
IP-7/570	570				89.0					
IP-7/640	640				90.0					
IP-7/720	720				91.5					
IP-7/810	810				93.0					
IP-9/630	630	258	495	177	105.0	11.0	400Δ	50	19.7	2930
IP-9/690	690				105.5					
IP-9/760	760				106.5					

* M16x1,5 cable gland is used on IP 1 pump.

** The performance curves are based on 1 mm²/s (cSt) kinematic viscosity values and 997 kg/m³ density

*** Curve tolerance according to ISO 9906:2012 Grade 3B.

Fluid Specifications:

- Coolants,
- Cutting oils,
- Grinding oils,
- Water,
- Chip contains liquids (max. 8mm)
- Fluid temperature 0...80 °C
- Kinematic viscosity 1...90 mm²/s

Materials:

- Pump body : Cast iron - DIN GG 25
- Volute : Cast iron - DIN GG 25
- Impeller : Investment casting steel - AISI 4140 (DIN 42CrMo4)
- Pump shaft : Engineering steel - AISI 1040 (DIN C35)
- Electric motor : 3 phase induction motor IE3 - 2 pole
Protection degree IP 55

IPA/IPF PUMP

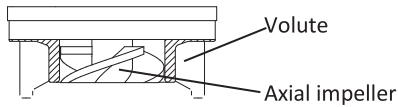

IPA - Axial front impeller pump

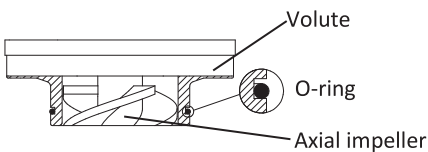

IPF - Axial front impeller pump with O-ring

Performance Curve

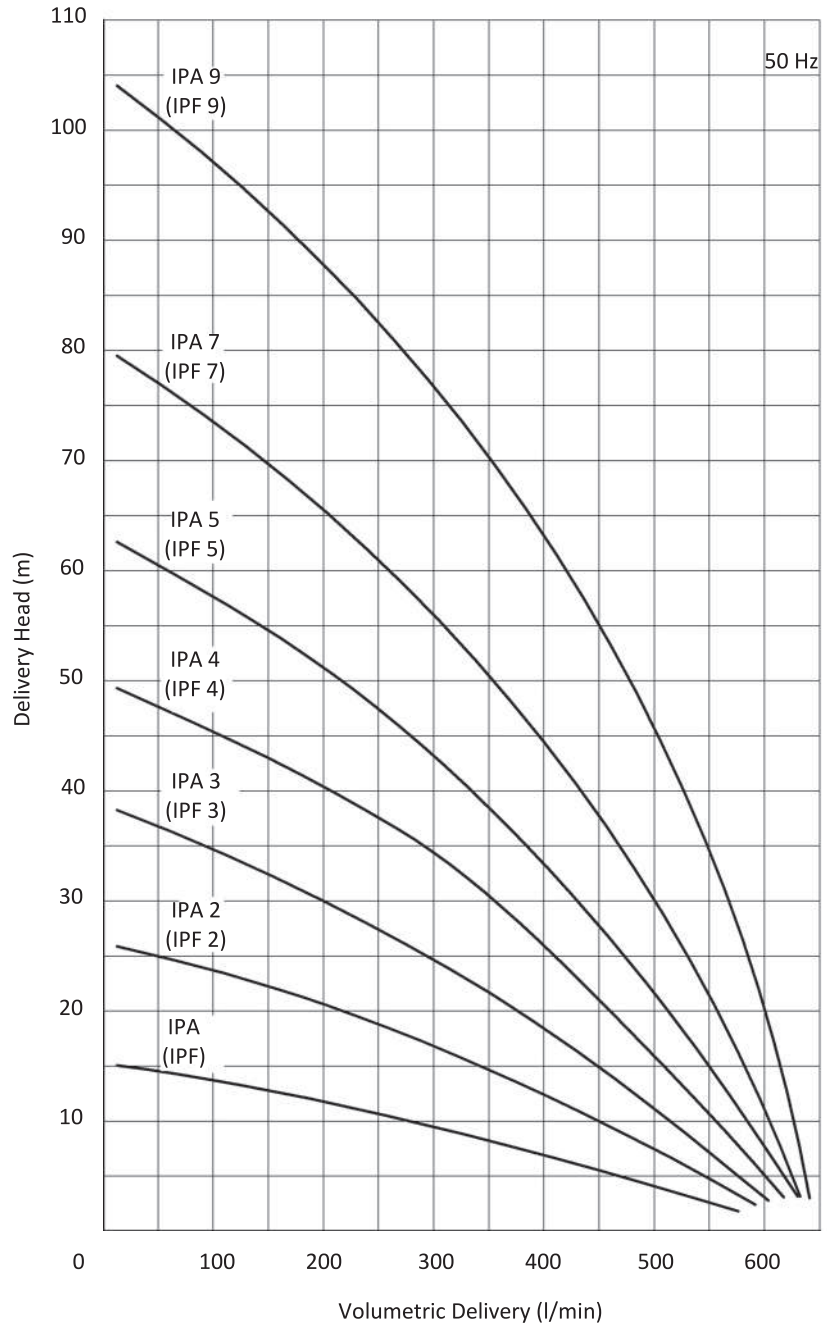

IPA PUMP

Applications:

- IPA pump has an additional axial impeller,
- It is used for pumping the liquid foam resulting from high-speed machining operations,
- Pumping metal chips together with the fluid by mixing,
- Filtration systems,
- Hot liquid applications,
- IPA Pumps are used for pumping of cutting / cooling fluids in circulation systems.

Fluid Specifications:

- Coolants,
- Cutting oils,
- Grinding oils,
- Water,
- Fluid temperature 0...80 °C
- Kinematic viscosity 1...90 mm²/s

DIMENSIONS & NOMINAL VALUES

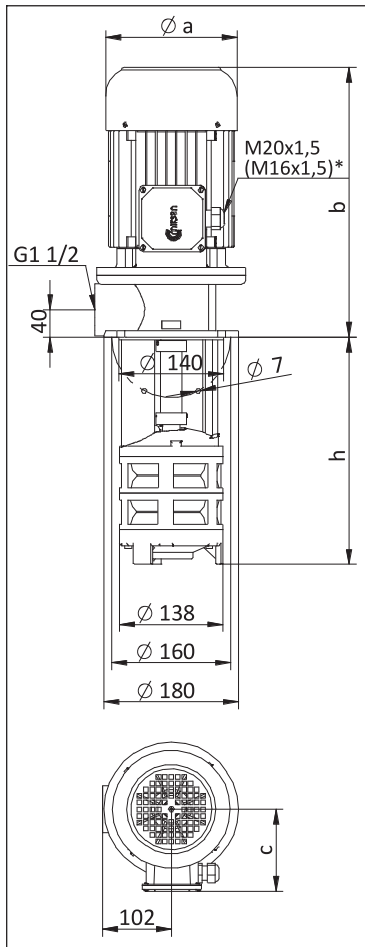

TYPE	Depth of immersion h (mm)	mm			Weight kg	Power kW	Voltage V(Δ/Y)	Frequency Hz	Rated current A	Speed rpm
		a	b	c						
IPA(F) /210	210	157	319	118	24.5	1.1	230/400	50	4.16/2.4	2890
IPA(F) /280	280				26.0					
IPA(F) /360	360				27.0					
IPA(F) /450	450				28.5					
IPA(F) /560	560				30.5					
IPA(F) -2/210	210	176	363	139	34.5	2.2	230/400	50	7.79/4.5	2905
IPA(F) -2/270	270				35.0					
IPA(F) -2/340	340				36.0					
IPA(F) -2/420	420				37.0					
IPA(F) -2/510	510				38.5					
IPA(F) 2/620	620				40.5					
IPA(F) -3/270	270	194	398	150	47.0	4.0	230/400	50	13.68/7.9	2900
IPA(F) -3/330	330				47.5					
IPA(F) -3/400	400				48.5					
IPA(F) -3/480	480				50.0					
IPA(F) -3/570	570				51.5					
IPA(F) -3/680	680				53.5					
IPA(F) -4/330	330	218	412	163	54.5	5.5	230/400	50	17.15/9.9	2900
IPA(F) -4/390	390				55.0					
IPA(F) -4/460	460				56.0					
IPA(F) -4/540	540				57.5					
IPA(F) -4/630	630				59.0					
IPA(F) -4/740	740				61.0					
IPA(F) -5/390	390	218	412	163	58.0	5.5	230/400	50	17.15/9.9	2900
IPA(F) -5/450	450				58.5					
IPA(F) -5/520	520				59.5					
IPA(F) -5/600	600				61.0					
IPA(F) -5/690	690				62.5					
IPA(F) -7/510	510	258	495	177	89.0	7.5	400Δ	50	14.0	2930
IPA(F) -7/570	570				89.5					
IPA(F) -7/640	640				90.5					
IPA(F) -7/720	720				92.0					
IPA(F) -7/810	810				93.5					
IPA(F) -9/630	630	258	495	177	105.5	11.0	400Δ	50	19.7	2930
IPA(F) -9/690	690				106.0					
IPA(F) -9/760	760				107.0					

* M16x1,5 cable gland is used on IPA(F) 1 pump.

** The performance curves are based on 1 mm²/s (cSt) kinematic viscosity values and 997 kg/m³ density

*** Curve tolerance according to ISO 9906:2012 Grade 3B.

IPF PUMP

Applications:

- IPF pumps are used for pumping of liquid from vacuum zone on filtration systems. The pump works at vacuum zone, therefore it has an O-ring at the pump inlet. It also has an additional axial front impeller.

Fluid Specifications:

- Coolants,
- Cutting oils,
- Grinding oils,
- Water,
- Fluid temperature 0...80 °C
- Kinematic viscosity 1...90 mm²/s

Materials:

Pump body	: Cast iron - DIN GG 25
Volute	: Cast iron - DIN GG 25
Impeller	: Investment casting steel - AISI 4140 (DIN 42CrMo4)
Axial (front) impeller	: Investment casting steel - AISI 4140 (DIN 42CrMo4)
O-ring	: Viton
Pump shaft	: Engineering steel - AISI 1040 (DIN C35)
Electric motor	: 3 phase induction motor IE3 - 2 pole Protection degree IP 54

IPH PUMP

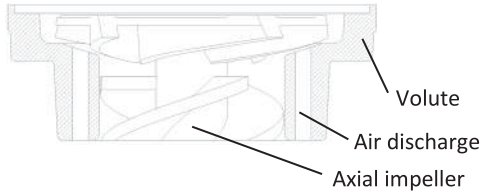

IPH - Axial front impeller with air release

Performance Curve

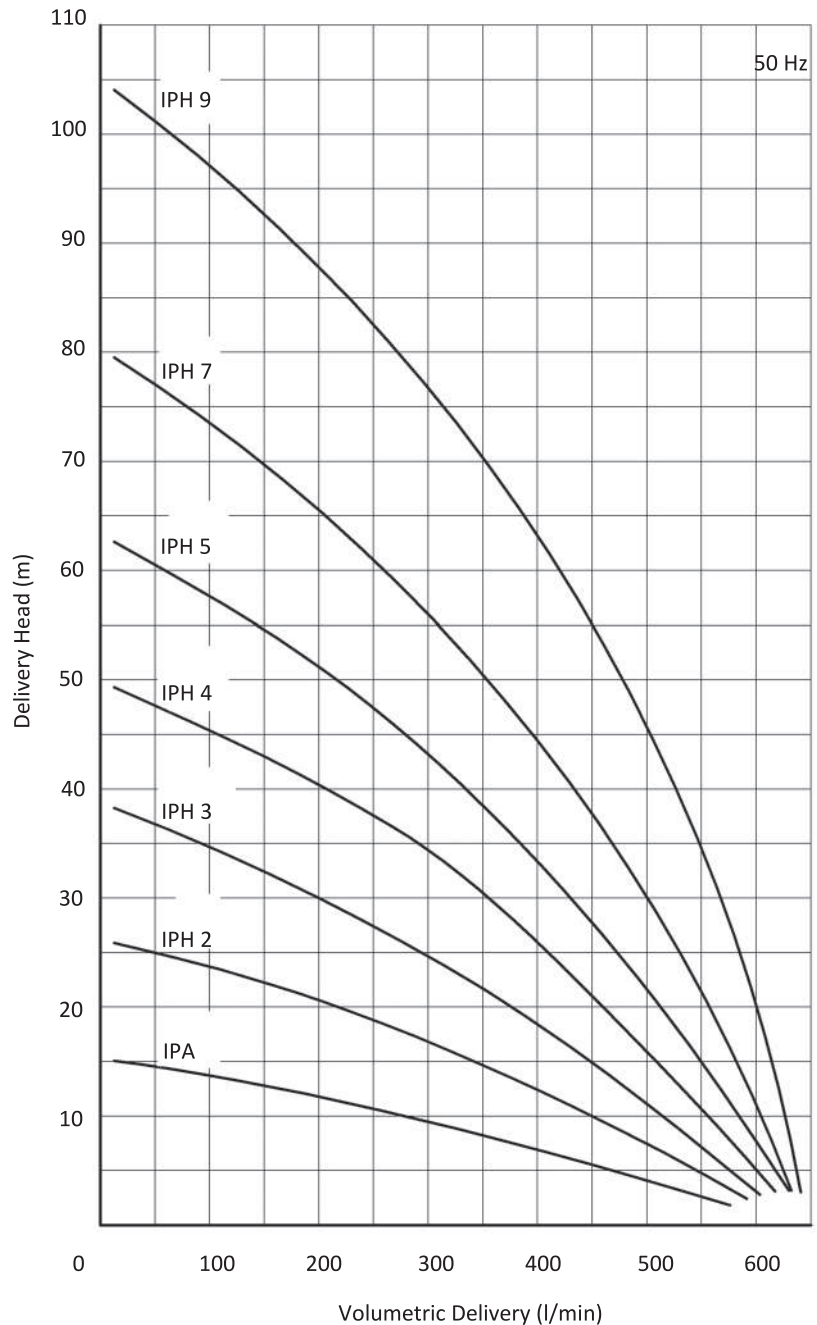

IPH PUMP

Applications:

- IPH pump has an additional axial impeller,
- It is used for pumping the liquid foam resulting from high-speed machining operations,
- Pumping metal chips together with the fluid by mixing,
- Filtration systems,
- Hot liquid applications,
- IPH Pumps are used for pumping of cutting / cooling fluids in circulation systems.

Fluid Specifications:

- Coolants,
- Cutting oils,
- Grinding oils,
- Water,
- Fluid temperature 0...80 °C
- Kinematic viscosity 1...90 mm²/s

DIMENSIONS & NOMINAL VALUES

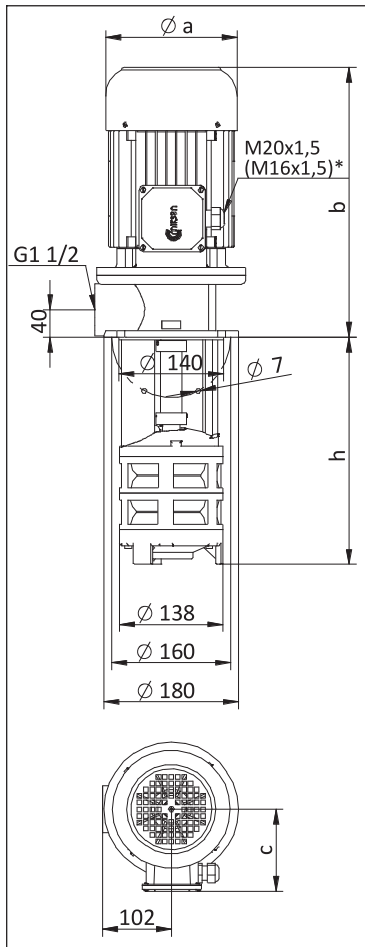

TYPE	Depth of immersion h (mm)	mm			Weight kg	Power kW	Voltage V(Δ/Y)	Frequency Hz	Rated current A	Speed rpm
		a	b	c						
IPH /210	210	157	319	118	24.5	1.1	230/400	50	4.16/2.4	2890
IPH /280	280				26.0					
IPH /360	360				27.0					
IPH /450	450				28.5					
IPH /560	560				30.5					
IPH -2/210	210	176	363	139	34.5	2.2	230/400	50	7.79/4.5	2905
IPH -2/270	270				35.0					
IPH -2/340	340				36.0					
IPH -2/420	420				37.0					
IPH -2/510	510				38.5					
IPH 2/620	620				40.5					
IPH -3/270	270	194	398	150	47.0	4.0	230/400	50	13.68/7.9	2900
IPH -3/330	330				47.5					
IPH -3/400	400				48.5					
IPH -3/480	480				50.0					
IPH -3/570	570				51.5					
IPH -3/680	680				53.5					
IPH -4/330	330	218	412	163	54.5	5.5	230/400	50	17.15/9.9	2900
IPH -4/390	390				55.0					
IPH -4/460	460				56.0					
IPH -4/540	540				57.5					
IPH -4/630	630				59.0					
IPH -4/740	740				61.0					
IPH -5/390	390	218	412	163	58.0	5.5	230/400	50	17.15/9.9	2900
IPH -5/450	450				58.5					
IPH -5/520	520				59.5					
IPH -5/600	600				61.0					
IPH -5/690	690				62.5					
IPH -7/510	510	258	495	177	89.0	7.5	400Δ	50	14.0	2930
IPH -7/570	570				89.5					
IPH -7/640	640				90.5					
IPH -7/720	720				92.0					
IPH -7/810	810				93.5					
IPH -9/630	630	258	495	177	105.5	11.0	400Δ	50	19.7	2930
IPH -9/690	690				106.0					
IPH -9/760	760				107.0					

* M16x1,5 cable gland is used on IPH 1 pump.

** The performance curves are based on 1 mm²/s (cSt) kinematic viscosity values and 997 kg/m³ density

*** Curve tolerance according to ISO 9906:2012 Grade 3B.

Materials:

Pump body	: Cast iron - DIN GG 25
Volute	: Cast iron - DIN GG 25
Impeller	: Investment casting steel - AISI 4140 (DIN 42CrMo4)
Axial (front) impeller	: Investment casting steel - AISI 4140 (DIN 42CrMo4)
O-ring	: Viton
Pump shaft	: Engineering steel - AISI 1040 (DIN C35)
Electric motor	: 3 phase induction motor IE3 - 2 pole Protection degree IP 54

J SERIES MODULAR PUMPS

J series pumps offer open impeller, vortex impeller and axial impeller options within the same model series. In this series; electric motor, coupling, pump body and shaft are common, impeller and volute are changing. So J pumps are called as Modular Pumps.

The main applications are;

- Filtration systems,
- Treatment systems,
- Machine tool applications requiring high flow rates,
- Circulation systems.

Impeller and volute designs was optimized after R&D activities so announced targets at the beginning of the Project has increased and reached to %72 pump efficiency on JB pump.

The main application area of these pumps are filtration and treatment systems so the pumps are designed for pumping of the metal chips within the liquids. Allowed chips dimensions are;

JB Pump (Open impeller)	: Max. 10 mm
JBA Pump (Open + axial impeller)	: Max. 10 mm
JC Pump (Open impeller)	: Max. 15 mm
JCA Pump (Open + axial impeller)	: Max. 15 mm
JD Pump (Vortex impeller)	: Max. 50 mm
JE Pump (Non-clogging impeller)	: Max. 30 mm
JF Pump (Open impeller)	: Max. 15 mm

JBA/JCA Series pumps have an axial front impeller. It is used for pumping of metal chips in the fluid by mixing to coolant tank.

Model names of J series pumps have shown in Figure 25, and modularity and components have shown in Figure 26.

Diffuser

Diffuser is made of cast iron. It is only used in multistage JB/A - JC/A pump.

Electric Motor

Special shaft and flange mounted electric motors are used on J series pumps. Motor shaft are connected to pump shaft via a coupling. Motor flange are made of cast iron and the front bearing is bigger than standard electric motors so it increases to the strength against to axial forces.

Power of 3 phase IE3 electric motors are between 1,5 kW and 11,0 kW; frame sizes are between 90 and 132. JD series can be suitable to run with 1,1 kW - 4 pole motor.

Pump Body

Pump body is made of cast iron for preventing the vibration. Immersion depth of the pump can be extended by using three units pump body.

Cover

Cover is made of cast iron and it keeps to SiC bearings. It has been designed for using together different impeller and volute for supply to modularity.

Volute

J pump family has two type volute basically. One of them is classic type volute (JB/A-JC/A-JF pumps), another type is vortex type volute (JD/JE pump) to allow passage of bigger chip size.

Impeller

Impellers of JB/A pump are made of investment casting steel, JC, JD and JE pump impellers are made of cast iron, and they are considered various applications in the design stage. Because of material characteristic, low surface roughness has increased to pump efficiency. However, as an advantage of the manufacturing process, high homogeneous level of the impeller allow to work with out any balance problem at 2900 rpm values.

Suction Cover

Suction cover is made of cast iron. It is only used in multistage JB/A - JC/A pump.

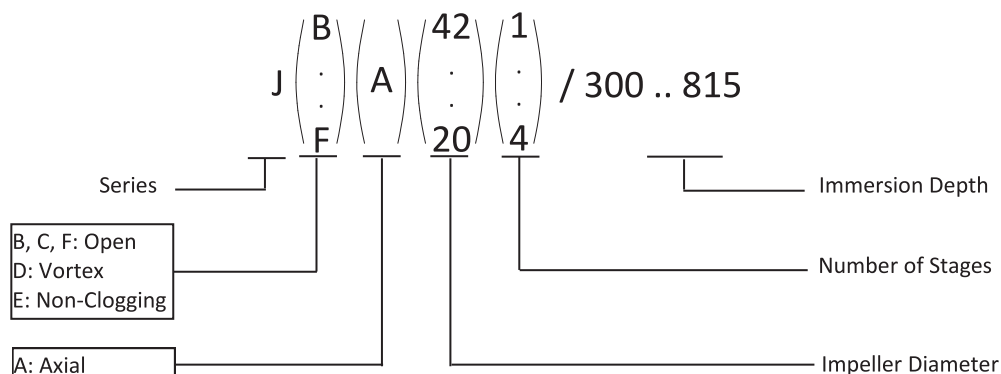

Figure 25 - Model names of the modular J Pump

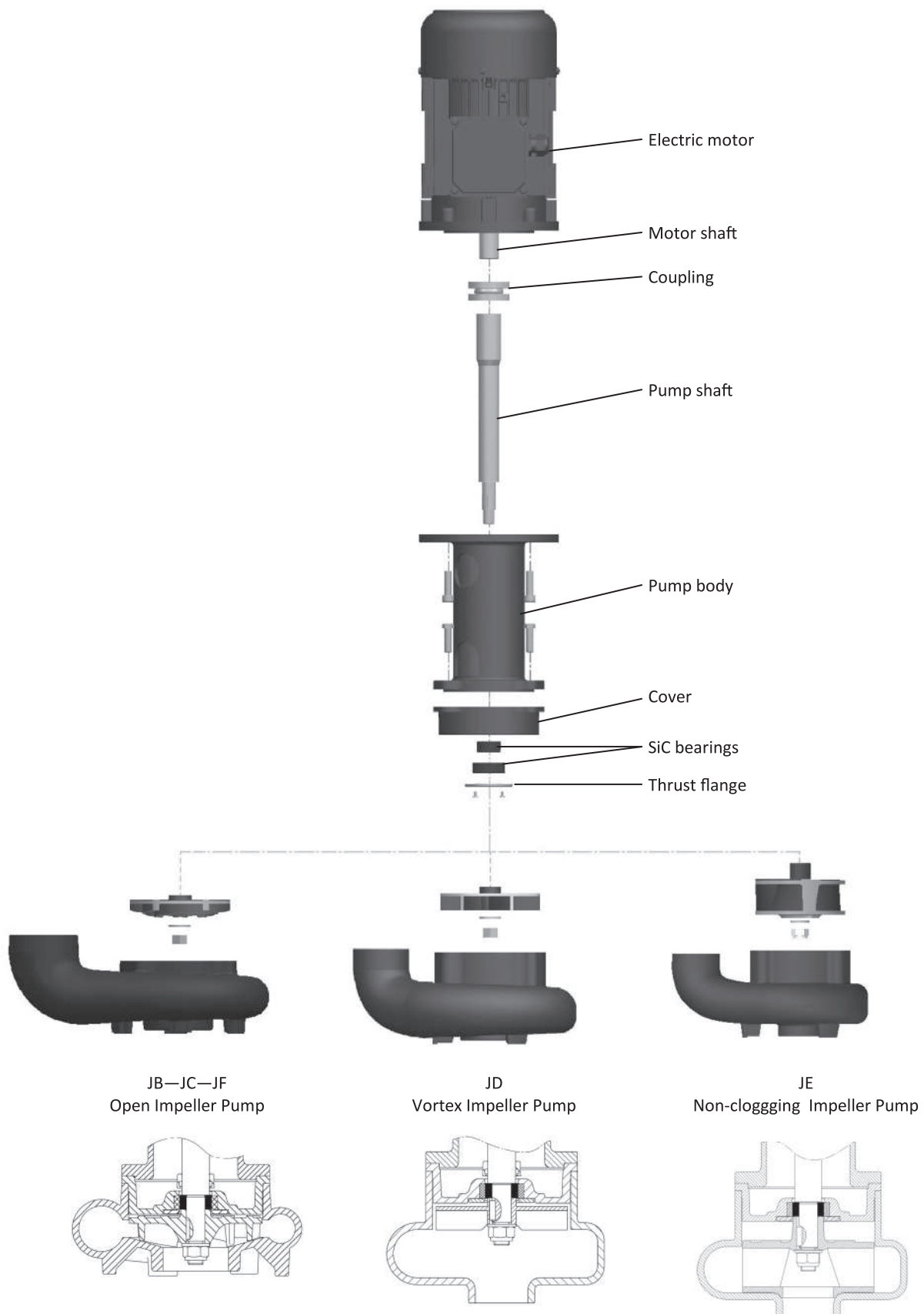

Figure 26 - Parts of the modular J Pump



JB 200 PUMP

Applications:

- Cutting, turning, milling, boring, grinding and similar applications of the machine tools,
- Filtration systems,
- Treatment systems,
- Cooling systems,
- Circulation systems. JB Pumps are used for pumping of cutting / cooling fluids.

Fluid Specifications:

- Coolants,
- Cutting oils,
- Grinding oils,
- Water,
- Chip contains liquids (max. 10mm)
- Fluid temperature 0...80 °C
- Kinematic viscosity 1...90 mm²/s

Materials:

Pump body	: Cast iron - DIN GG 25
Volute	: Cast iron - DIN GG 25
Diffusor	: Cast iron - DIN GG 25
Suction Cover	: Cast iron - DIN GG 25
Impeller	: Investment casting steel - AISI 4140 (DIN 42CrMo4)
Pump shaft	: Engineering steel - AISI 1040 (DIN C35)
Electric motor	: 3 phase induction motor IE3 - 2 pole Protection degree IP 55

* JB 200 pumps can be optionally equipped with an axial impeller.

** Please contact us for different immersion depth.

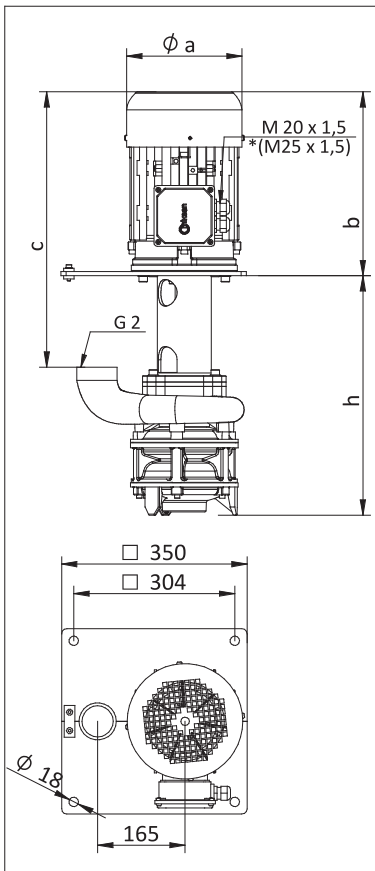

DIMENSIONS & NOMINAL VALUES

TYPE	Depth of Immersion h (mm)	a	b	c	Weight kg	Power kW	Voltage V(Δ /Y)	Frequency Hz	Rated current A	Speed rpm
		mm								
JB 201/300	300	176	274	446	40.5	1.5	230/400	50	5.72/3.3	2910
JB 201/520	520			666	47.0					
JB 201/740	740			886	53.5					
JB 202/375	375	194	338	510	55.5	3.0	230/400	50	10.39/6.0	2905
JB 202/595	595			730	62.0					
JB 202/815	815			950	68.5					
JB 203/450	450	218	347	519	69.5	5.5	230/400	50	17.15/9.9	2900
JB 203/670	670			739	76.0					
JB 204/525	525	258	438	610	100.0	7.5	400 Δ	50	14.0	2930
JB 204/745	745			830	106.5					

* The performance curves are based on $1 \text{ mm}^2/\text{s}$ (cSt) kinematic viscosity values and 997 kg/m^3 density
 ** Curve tolerance according to ISO 9906:2012 Grade 3B.

Performance Curve

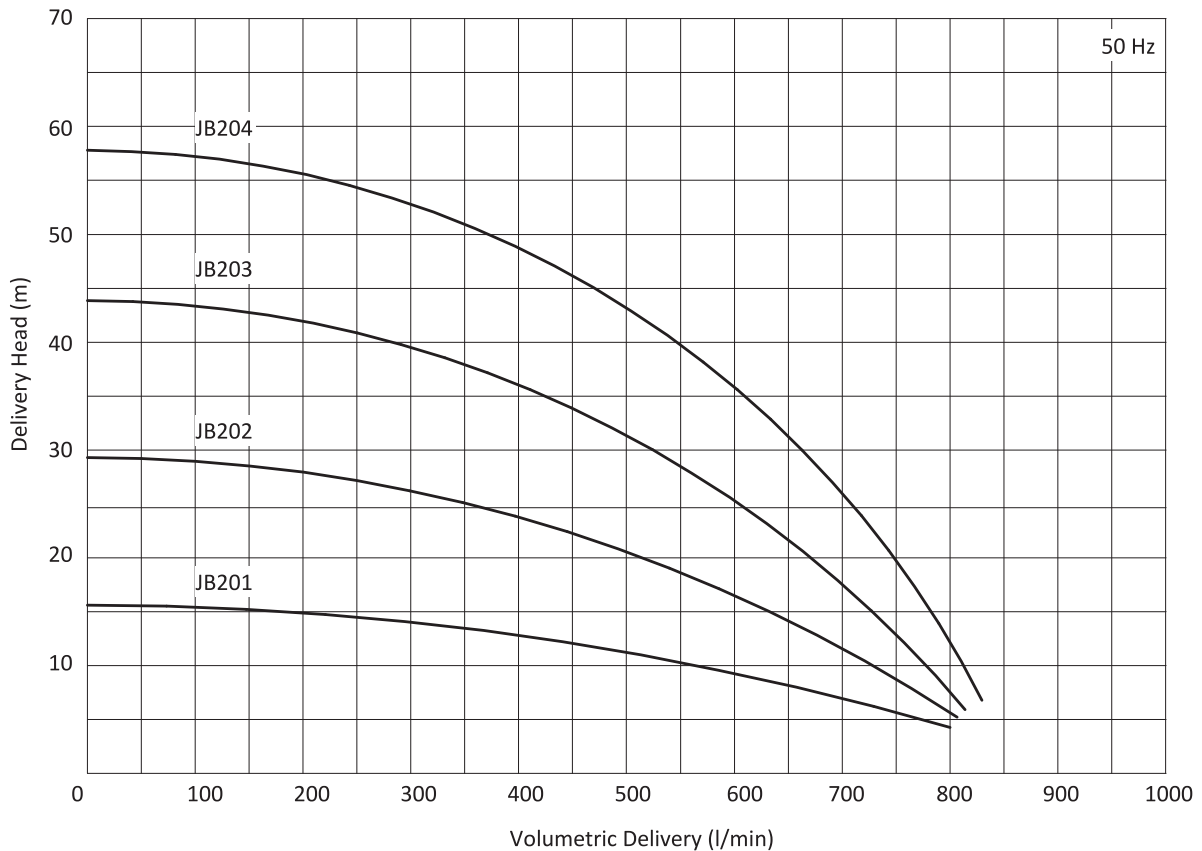



JB 350 PUMP

Applications:

- Cutting, turning, milling, boring, grinding and similar applications of the machine tools,
- Filtration systems,
- Treatment systems,
- Cooling systems,
- Circulation systems. JB Pumps are used for pumping of cutting / cooling fluids.

Fluid Specifications:

- Coolants,
- Cutting oils,
- Grinding oils,
- Water,
- Chip contains liquids (max. 10mm)
- Fluid temperature 0...80 °C
- Kinematic viscosity 1...90 mm²/s

Materials:

Pump body	: Cast iron - DIN GG 25
Volute	: Cast iron - DIN GG 25
Diffusor	: Cast iron - DIN GG 25
Suction Cover	: Cast iron - DIN GG 25
Impeller	: Investment casting steel - AISI 4140 (DIN 42CrMo4)
Pump shaft	: Engineering steel - AISI 1040 (DIN C35)
Electric motor	: 3 phase induction motor IE3 - 2 pole Protection degree IP 55

* JB 350 pumps can be optionally equipped with an axial impeller.

** Please contact us for different immersion depth.

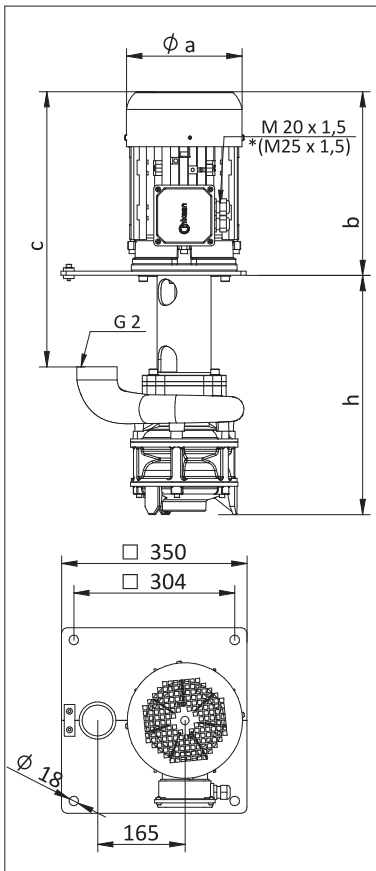

DIMENSIONS & NOMINAL VALUES

TYPE	Depth of Immersion h (mm)	a	b	c	Weight kg	Power kW	Voltage V(Δ/Y)	Frequency Hz	Rated current A	Speed rpm
		mm								
JB 351/300	300	176	299	471	43.5	2.2	230/400	50	7.79/4.5	2905
JB 351/520	520			519	50.0					
JB 351/740	740			567	56.5					
JB 352/375	375	194	338	510	58.5	4.0	230/400	50	13.68/7.9	2900
JB 352/595	595			730	65.0					
JB 352/815	815			950	71.5					
JB 353/450	450	258	438	610	93.0	7.5	400Δ	50	14.0	2930
JB 353/670	670			830	99.5					
JB 354/525	525	258	438	610	109.0	11.0	400Δ	50	19.7	2930
JB 354/745	745			830	115.5					

* The performance curves are based on 1 mm²/s (cSt) kinematic viscosity values and 997 kg/m³ density
 ** Curve tolerance according to ISO 9906:2012 Grade 3B.

Performance Curve

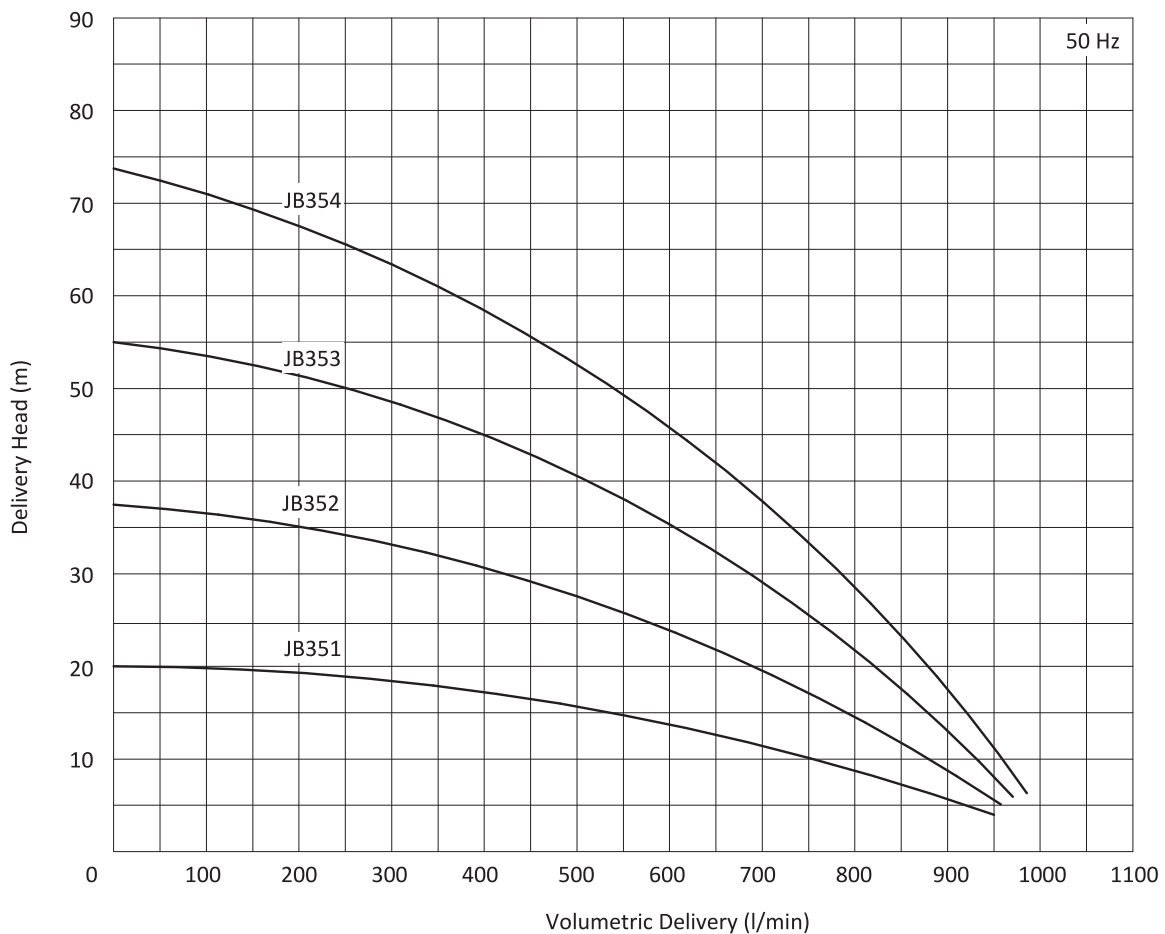



JB 420 PUMP

Applications:

- Cutting, turning, milling, boring, grinding and similar applications of the machine tools,
- Filtration systems,
- Treatment systems,
- Cooling systems,
- Circulation systems. JB Pumps are used for pumping of cutting / cooling fluids.

Fluid Specifications:

- Coolants,
- Cutting oils,
- Grinding oils,
- Water,
- Chip contains liquids (max. 10mm)
- Fluid temperature 0...80 °C
- Kinematic viscosity 1...90 mm²/s

Materials:

Pump body	: Cast iron - DIN GG 25
Volute	: Cast iron - DIN GG 25
Diffusor	: Cast iron - DIN GG 25
Suction Cover	: Cast iron - DIN GG 25
Impeller	: Investment casting steel - AISI 4140 (DIN 42CrMo4)
Pump shaft	: Engineering steel - AISI 1040 (DIN C35)
Electric motor	: 3 phase induction motor IE3 - 2 pole Protection degree IP 55

* JB 420 pumps can be optionally equipped with an axial impeller.

** Please contact us for different immersion depth.

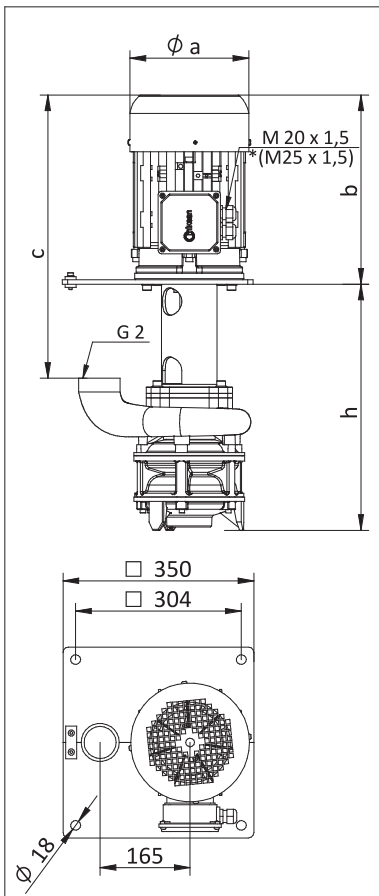

DIMENSIONS & NOMINAL VALUES

TYPE	Depth of Immersion h (mm)	a	b	c	Weight kg	Power kW	Voltage V(Δ/Y)	Frequency Hz	Rated current A	Speed rpm
		mm								
JB 421/300	300	194	338	510	49.5	3.0	230/400	50	10.39/6.0	2905
JB 421/520	520			730	56.0					
JB 421/740	740			950	62.5					
JB 422/375	375	218	353	525	62.5	5.5	230/400	50	17.15/9.9	2900
JB 422/595	595			745	69.0					
JB 423/450	450	258	438	610	93.5	7.5	400Δ	50	14.0	2930
JB 423/670	670			830	100.0					
JB 424/525	525	258	438	610	109.5	11.0	400Δ	50	19.7	2930
JB 424/745	745			830	116.0					

* The performance curves are based on 1 mm²/s (cSt) kinematic viscosity values and 997 kg/m³ density
 ** Curve tolerance according to ISO 9906:2012 Grade 3B.

Performance Curve

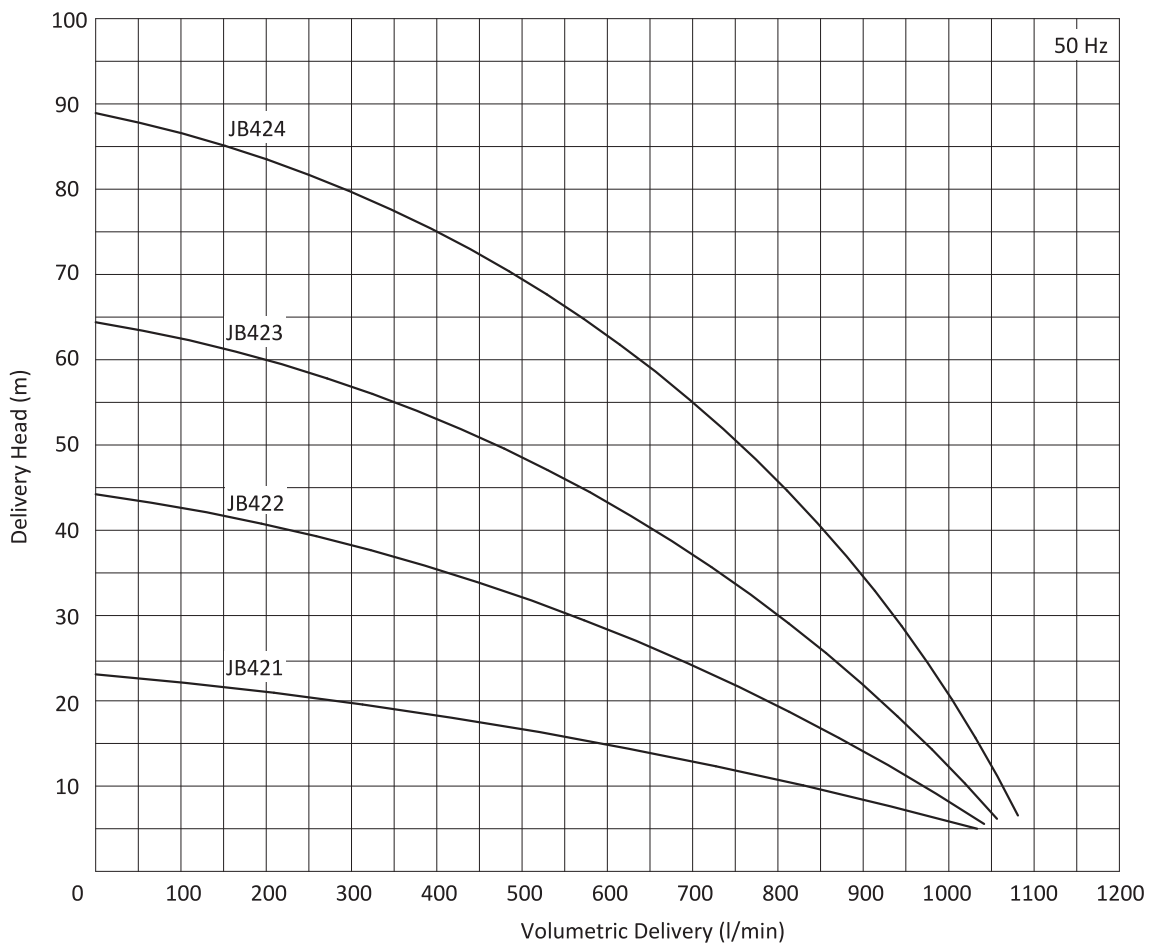



JC 420 PUMP

Applications:

- Cutting, turning, milling, boring, grinding and similar applications of the machine tools,
- Filtration systems,
- Treatment systems,
- Cooling systems,
- Circulation systems. JC Pumps are used for pumping of cutting / cooling fluids.

Fluid Specifications:

- Coolants,
- Cutting oils,
- Grinding oils,
- Water,
- Chip contains liquids (max. 15mm)
- Fluid temperature 0...80 °C
- Kinematic viscosity 1...90 mm²/s

Materials:

Pump body	: Cast iron - DIN GG 25
Volute	: Cast iron - DIN GG 25
Diffusor	: Cast iron - DIN GG 25
Suction Cover	: Cast iron - DIN GG 25
Impeller	: Cast iron - DIN GG 25
Pump shaft	: Engineering steel - AISI 1040 (DIN C35)
Electric motor	: 3 phase induction motor IE3 - 2 pole Protection degree IP 55

* JC 420 pumps can be optionally equipped with an axial impeller.

** Please contact us for different immersion depth.

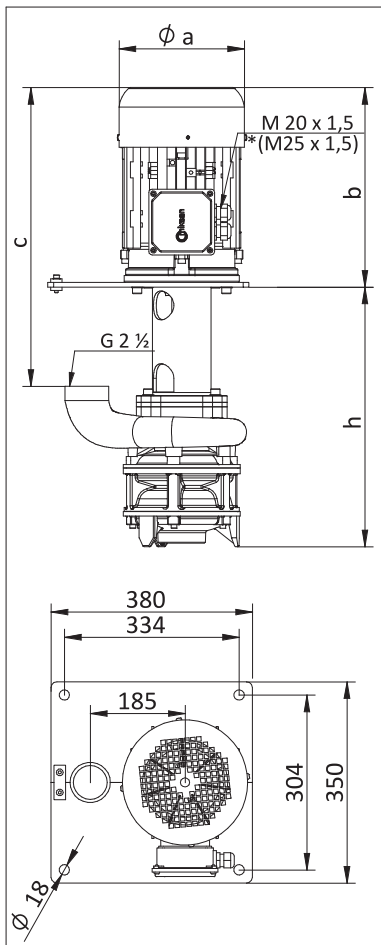

DIMENSIONS & NOMINAL VALUES

TYPE	Depth of Immersion h (mm)	mm			Weight kg	Power kW	Voltage V(Δ/Y)	Frequency Hz	Rated current A	Speed rpm
		a	b	c						
JC 421/310	310	194	338	510	56.0	4.0	230/400	50	13.68/7.9	2900
JC 421/530	530			730	62.5					
JC 421/750	750			950	69					
JC 422/395	395	258	438	610	89.5	7.5	400Δ	50	14.0	2930
JC 422/615	615			830	96.0					
JC 423/480	480	258	438	610	106.5	11.0	400Δ	50	19.7	2930
JC 423/700	700			830	113.0					

* The performance curves are based on 1 mm²/s (cSt) kinematic viscosity values and 997 kg/m³ density
 ** Curve tolerance according to ISO 9906:2012 Grade 3B.

Performance Curve

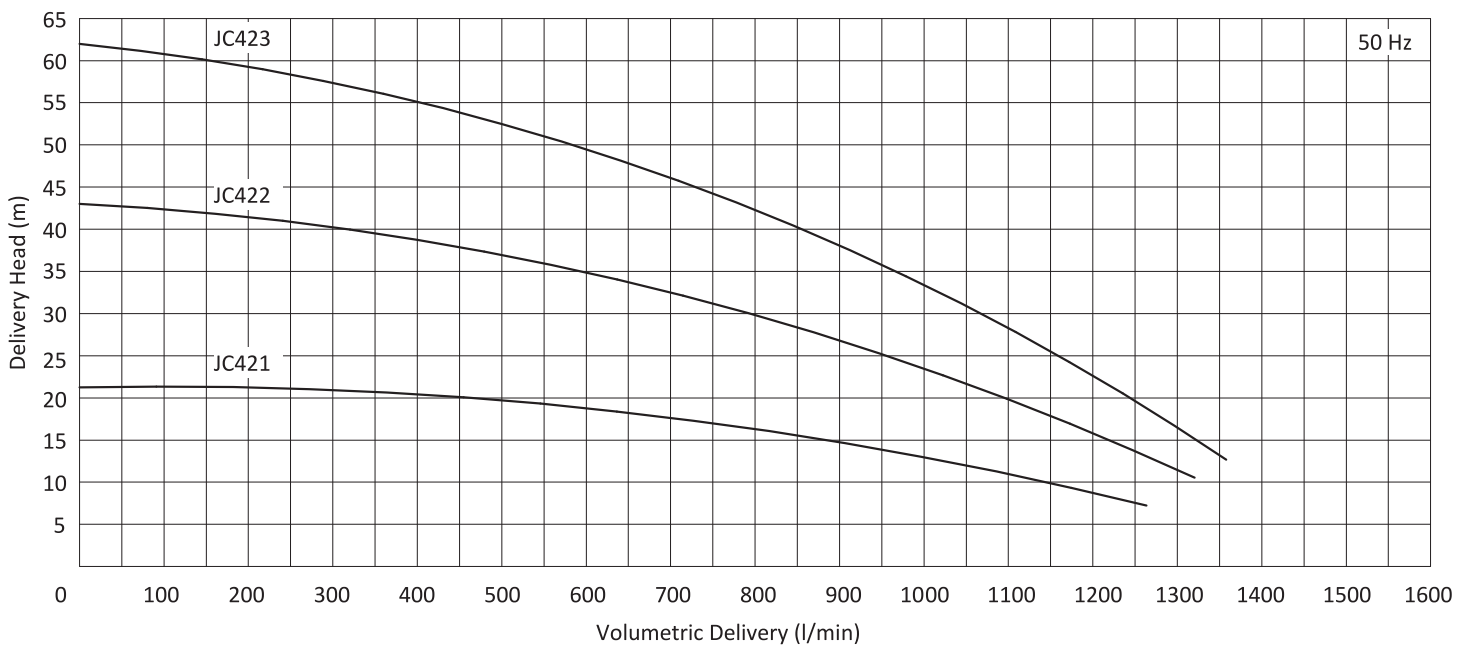



JD PUMP

Applications:

- Vortex type pump is used for pumping liquids which contains 50 mm metal chips.
- Filtration systems,
- Treatment systems,
- Cutting, turning, milling, boring, grinding and similar applications of the machine tools,
- Cooling systems,
- Circulation systems. JD Pumps are used for pumping of cutting / cooling fluids.

Fluid Specifications:

- Coolants,
- Cutting oils,
- Grinding oils,
- Water,
- Chip contains liquids (max. 50 mm)
- Fluid temperature 0...80 °C
- Kinematic viscosity 1...30 mm²/s (Please contact us for higher viscosities)

Materials:

Pump body	: Cast iron - DIN GG 25
Volute	: Cast iron - DIN GG 25
Impeller	: Cast iron - DIN GG 25
Pump shaft	: Engineering steel - AISI 1040 (DIN C35)
Electric motor	: 3 phase induction motor IE3 - 2 pole Optionally 4 pole, Protection degree IP 55

* Please contact us for different immersion depth.

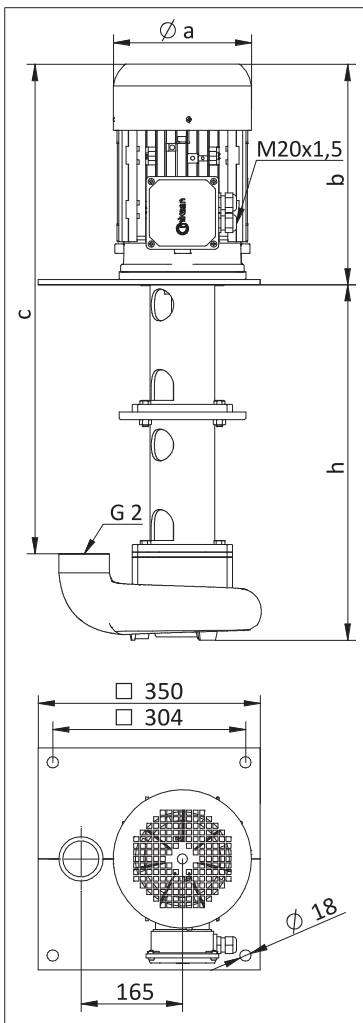

DIMENSIONS & NOMINAL VALUES

TYPE	Depth of Immersion h (mm)	mm			Weight kg	Power kW	Voltage V(Δ/Y)	Frequency Hz	Rated current A	Speed rpm
		a	b	c						
JD 200/345	345	194	338	552	51.5	3.0	230/400	50	10.39/6.0	2905
JD 200/565	565			772	58.0					
JD 200/785	785			992	64.5					
JD 320/345	345	194	338	552	54.5	4.0	230/400	50	13.68/7.9	2900
JD 320/565	565			772	61.0					
JD 370/345	345	218	353	567	58.5	5.5	230/400	50	17.15/9.9	2900
JD 370/565	565			787	65.0					
JD 370/345-4	345	176	303	517	42.0	1.1	230/400	50	4.85/2.8	1440
JD 370/565-4	565			737	48.5					
JD 370/785-4	785			957	55					

* The performance curves are based on 1 mm²/s (cSt) kinematic viscosity values and 997 kg/m³ density
 ** Curve tolerance according to ISO 9906:2012 Grade 3B.

Performance Curve

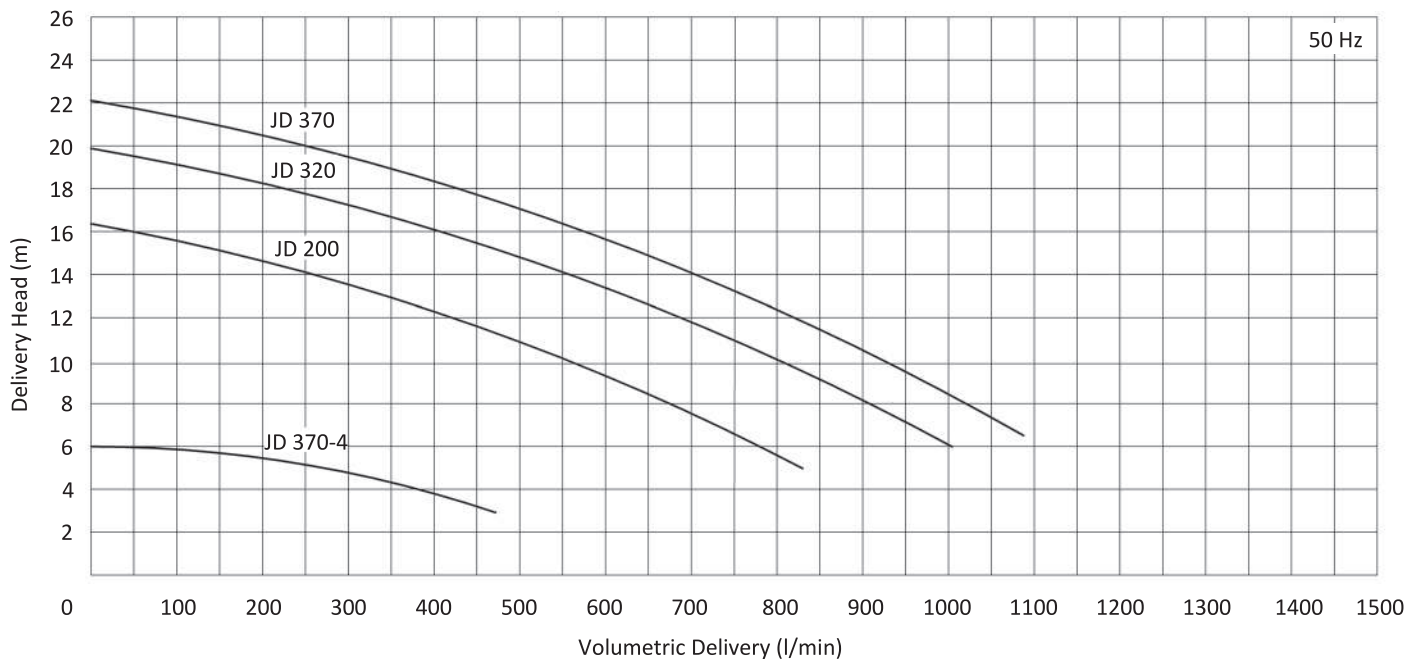



JE PUMP

Applications:

- Non-clogging type pump is used for pumping liquids which contains 35 mm metal chips.
- Filtration systems,
- Treatment systems,
- Cutting, turning, milling, boring, grinding and similar applications of the machine tools,
- Cooling systems,
- Circulation systems. JE Pumps are used for pumping of cutting / cooling fluids.

Fluid Specifications:

- Coolants,
- Cutting oils,
- Grinding oils,
- Dirty water and refining,
- Chip contains liquids (max. 30 mm)
- Fluid temperature 0...80 °C
- Kinematic viscosity 1...30 mm²/s (Please contact us for higher viscosities)

Materials:

Pump body	: Cast iron - DIN GG 25
Volute	: Cast iron - DIN GG 25
Impeller	: Cast iron - DIN GG 25
Pump shaft	: Engineering steel - AISI 1040 (DIN C35)
Electric motor	: 3 phase induction motor IE3 - 2 pole Protection degree IP 55

* Please contact us for different immersion depth.

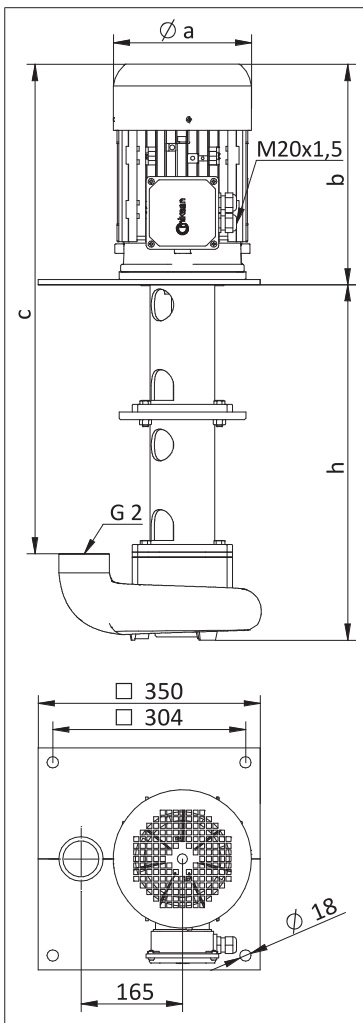

DIMENSIONS & NOMINAL VALUES

TYPE	Depth of Immersion h (mm)	mm			Weight kg	Power kW	Voltage V(Δ/Y)	Frequency Hz	Rated current A	Speed rpm
		a	b	c						
JE 340/345	345	218	353	567	61	5.5	230/400	50	17.15/9.9	2900
JE 340/565	565			787	67.5					
JE 340/785	785			1007	74					
JE 420/345	345	258	438	635	84.5	7.5	400Δ	50	14.0	2930
JE 420/565	565			855	91					
JE 420/785	785			1075	97.5					

* The performance curves are based on 1 mm²/s (cSt) kinematic viscosity values and 997 kg/m³ density
 ** Curve tolerance according to ISO 9906:2012 Grade 3B.

Performance Curve

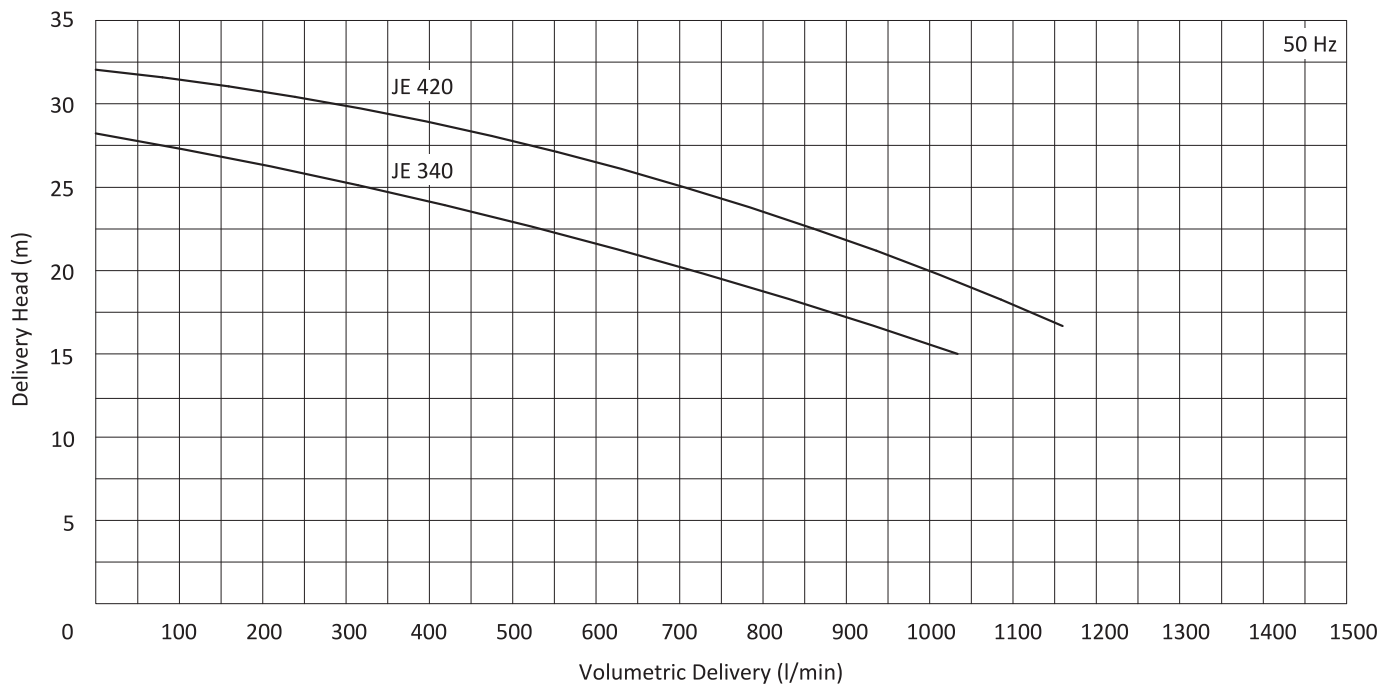

JF PUMP



Applications:

- Cutting, turning, milling, boring, grinding and similar applications of the machine tools,
- Filtration systems,
- Treatment systems,
- Cooling systems,
- Circulation systems. JF Pumps are used for pumping of cutting / cooling fluids.

Fluid Specifications:

- Coolants,
- Cutting oils,
- Grinding oils,
- Water,
- Chip contains liquids (max. 15mm)
- Fluid temperature 0...80 °C
- Kinematic viscosity 1...90 mm²/s

Materials:

Pump body	: Cast iron - DIN GG 25
Volute	: Cast iron - DIN GG 25
Impeller	: Cast iron - DIN GG 25
Pump shaft	: Engineering steel - AISI 1040 (DIN C35)
Electric motor	: 3 phase induction motor IE3 - 2 pole, Protection degree IP 55

* Please contact us for different immersion depth.

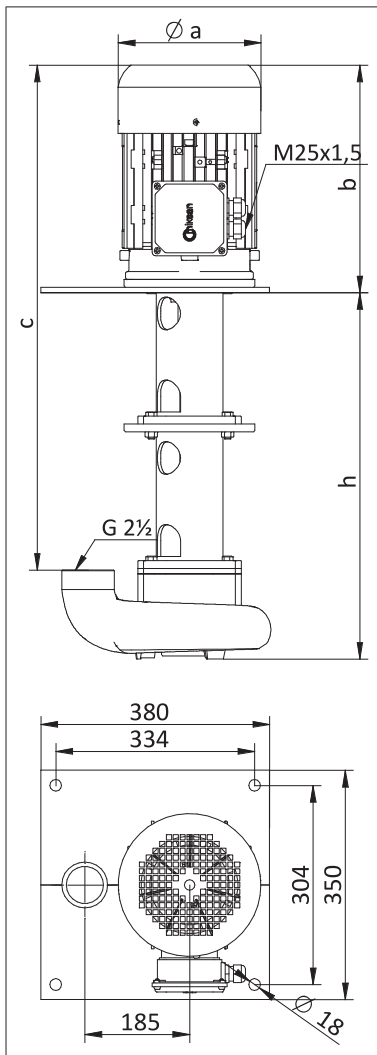

DIMENSIONS & NOMINAL VALUES

TYPE	Depth of Immersion h (mm)	mm			Weight kg	Power kW	Voltage V(Δ/Y)	Frequency Hz	Rated current A	Speed rpm
		a	b	c						
JF 420/310	310	258	438	610	84.5	7.5	400Δ	50	14.0	2930
JF 420/530	530			830	91					
JF 420/750	750			1050	97.5					

* The performance curves are based on 1 mm²/s (cSt) kinematic viscosity values and 997 kg/m³ density
 ** Curve tolerance according to ISO 9906:2012 Grade 3B.

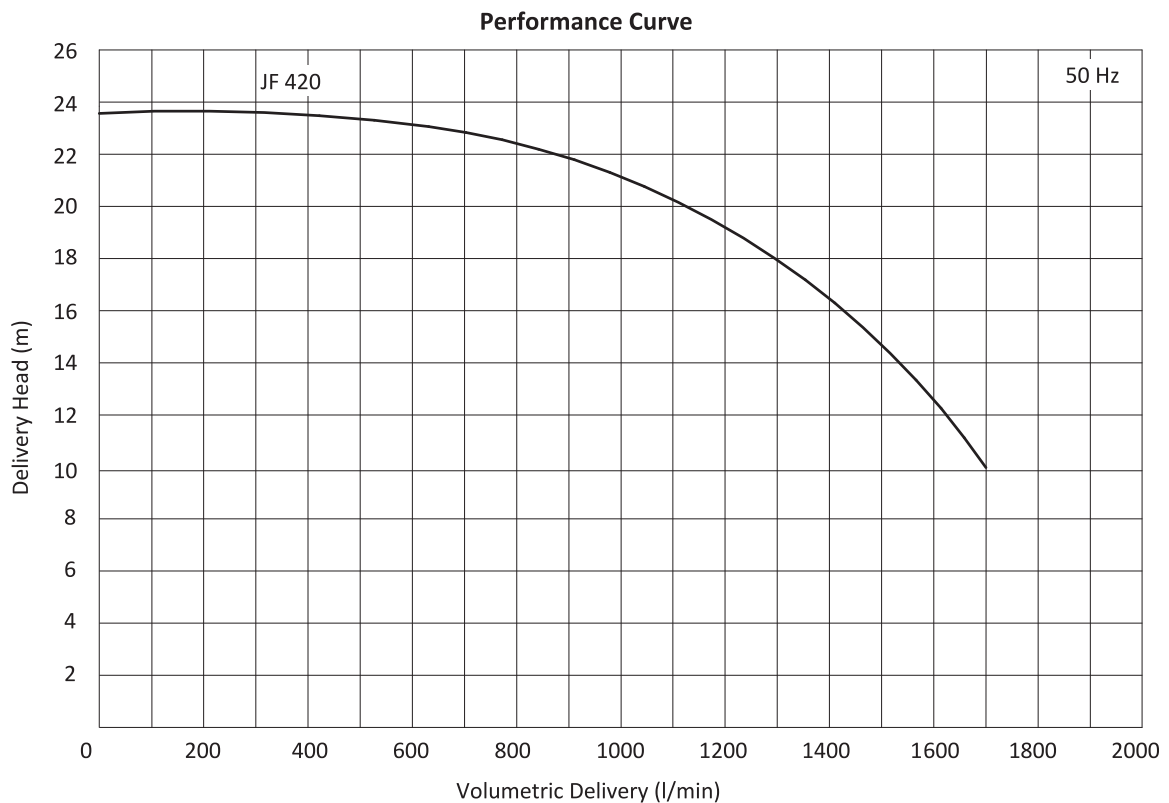

H SERIES HIGH PRESSURE PUMPS

H series pumps are closed impeller, multistage pumps and they are used for middle and high pressure pumping applications in industry extensively. Pump pressure can be raised from 1 bar to 25 bar due to multistage pump construction. When the pumps work as serial it possible to reach higher pressure.

The main applications of the high pressure pumps;

- CNC lathes,
- CNC machining centers,
- Especially deep hole boring operations,
- Erosion machines,
- Washing processes,
- Cooling systems.

Immersion depth of the high pressure pumps depend on stage quantity. It can be extended by using empty stages.

For example;

Immersion depth of HCB 10 pump is 291 mm but immersion depth of extended type HCB 10/25 is 606 mm (Please contact us for more details).

HCB, HDB and HEB type pumps are mostly used at deep hole boring applications on CNC machine tools. On deep hole boring applications, while work piece are drilled by cutting tool, coolant liquid are sprayed to the work piece get through from cutting tool. So work piece and cutting tool can be cold, metal chips can be thrown out via threads of the drilling tool. High pressure pumps work against the high piping resistance so they increase machining quality and life of the cutting tools.



Figure 27 - H series pumps

High pressure pumps' impellers and diffusers are made of stainless steel (AISI 304) so they have a good chemical resistance against to various chemical liquids. There are O-rings on the diffusers for reaching high pressure and preventing back flow to maintain high efficiency (Figure 29). O-rings are made of Viton for high chemical resistance.

Mechanical Seal

Mechanical seals are consist of four parts. These parts are; stable part, rotary part, bellows and spring. Mechanical seal materials must be choose according to liquid specifications and pump application type. These materials are shown on table 1.

Components	Type 1	Type 2
Stable Part	SiC	TC
Rotary Part	C	TC
Bellows	Viton	
Spring	Stainless steel	

Table 1 - Materials of the mechanical seals

- SiC : Silicon Carbide
- TC : Tungsten Carbide
- C : Resin-Impregnated Carbon
- V : Viton (FKM)

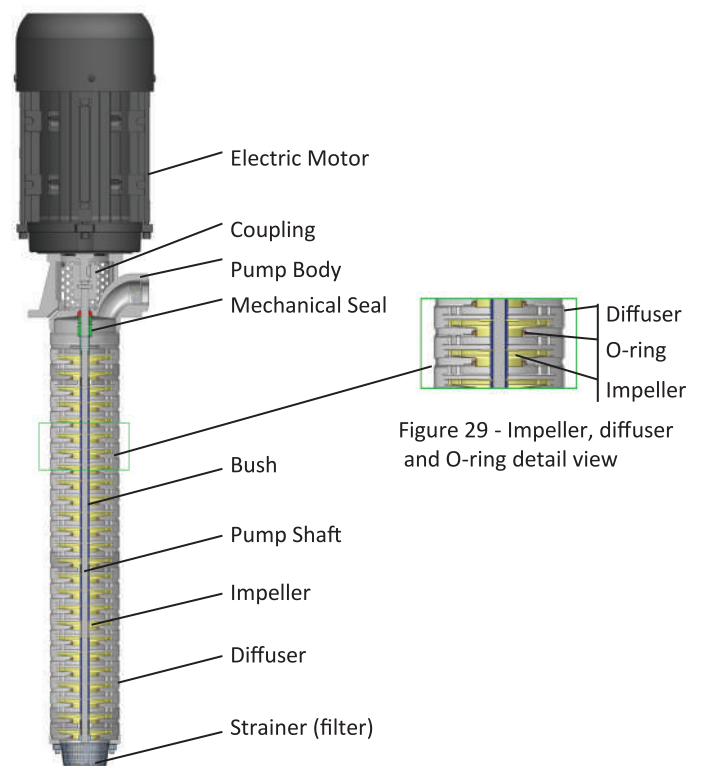

Figure 28 - H series pump section

Grinding Applications

If H series pumps will be used on grinding applications or filtration systems for pumping metal chip containing liquids, TC mechanical seals must be chosen. Because TC has a good mechanical resistance against to metal chips. So the pump can work without any problem.

Another important point is that O-ring is not used on the diffuser for these applications. Because metal dusts are abrasive so they can damage to O-rings.

Because of these reasons, H series pumps are produced without O-rings. So delivery head of the pump will be decrease and it must be considered on pump selection.

Delivery heads decrease rates are;

- HC / HCA / HCB Pumps : % 17
- HD / HDA / HDB Pumps : % 14
- HEB Pumps : % 7

Serial Connection of H Series Pump

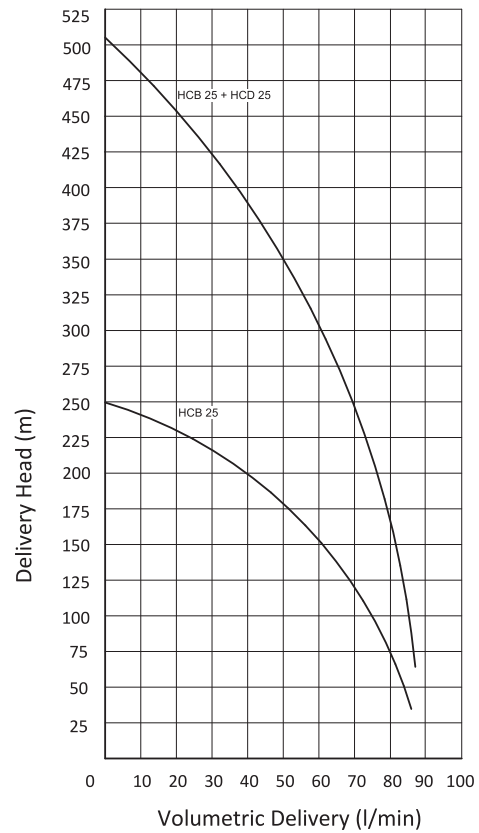
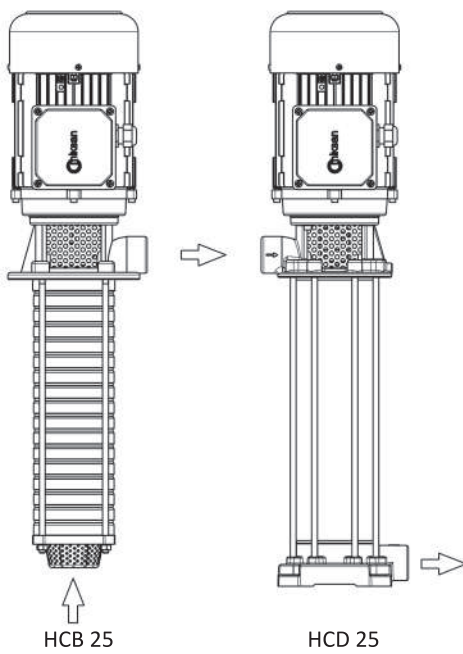

With +4 Bar of Positive Head

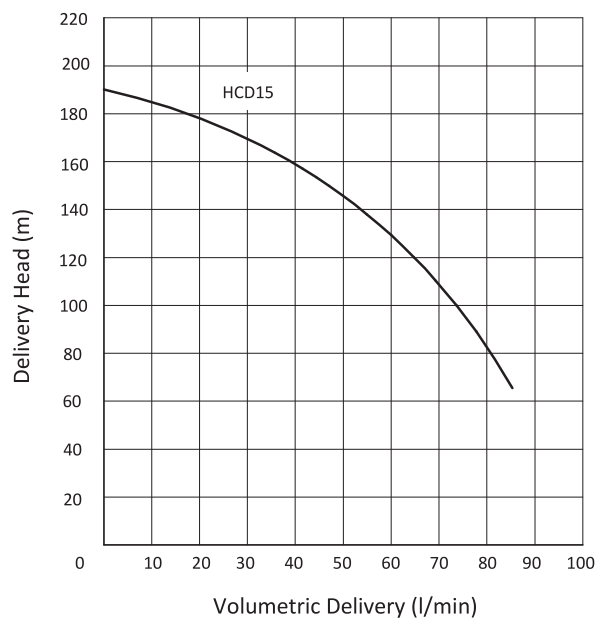
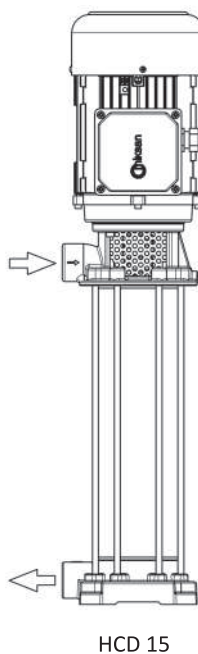

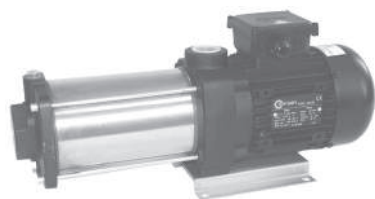

HC PUMP

Applications:

- Cutting, turning, milling, boring, grinding and similar applications of the machine tools,
- Erosion machines,
- Circulation systems. HC Pumps are used for pumping of cutting / cooling fluids.

Fluid Specifications:

- Coolants,
- Cutting oils,
- Grinding oils,
- Water,
- Fluid temperature 0...80 °C
- Kinematic viscosity 1...30 mm²/s

Materials:

Pump body	: Cast iron - DIN GG 25
Inlet body	: Cast iron - DIN GG 25
Diffuser	: Stainless steel - DIN 4301 (AISI 304)
Impeller	: Stainless steel - DIN 4301 (AISI 304)
Stage cover	: Stainless steel - DIN 4301 (AISI 304)
Pump shaft	: Stainless steel - DIN 4401 (AISI 316)
O-ring	: Viton
Mechanical seal	: C - SiC - Viton TC - TC - Viton (Optional)
Electric motor	: 3 phase induction motor - 2 pole, Protection degree IP 55

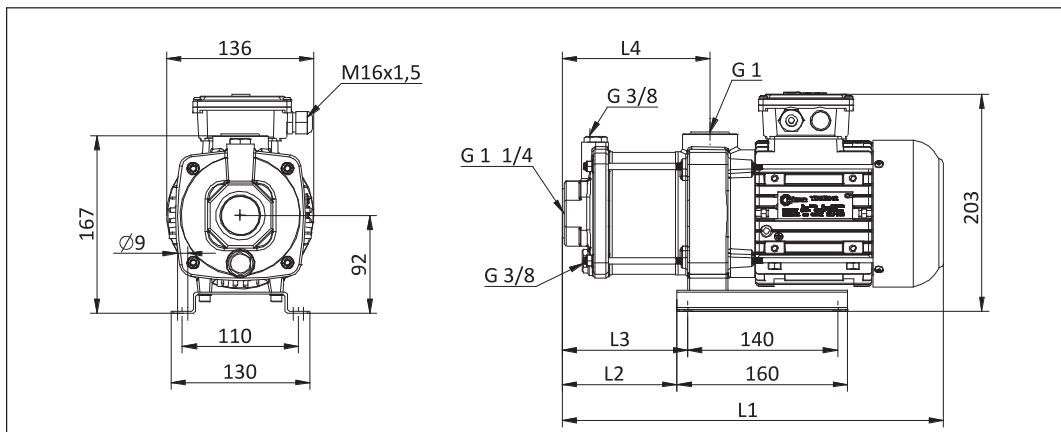

DIMENSIONS & NOMINAL VALUES

TYPE	L4	L3	L2	L1	Weight kg	Power kW	Voltage V(Δ/Y)	Frequency Hz	Rated current A	Speed rpm
	mm									
HC/02	137	116	106	356	11.8	0.37	230/400	50	1.84/1.05	2790
HC/03	158	137	127	377	13.1	0.55			2.25/1.3	2780
HC/04	179	158	148	398	15.0	0.75			3.12/1.8	2820
HC/05	200	179	169	419	15.1	1.10			4.85/2.8	2720
HC/06	221	200	190	440	15.3	1.10			4.85/2.8	2720
HC/07	242	221	211	461	15.5	1.10			4.85/2.8	2720

- * The performance curves are based on 1 mm²/s (cSt) kinematic viscosity values and 997 kg/m³ density
- ** Curve tolerance according to ISO 9906:2012 Grade 3B.
- *** HC/05, HC/06 and HC/07 pumps have IE2 motors. According to IEC 60034-30-1:2014 standard these pumps are excluded from efficiency class since their motors are completely integrated into the pump.

Performance Curve

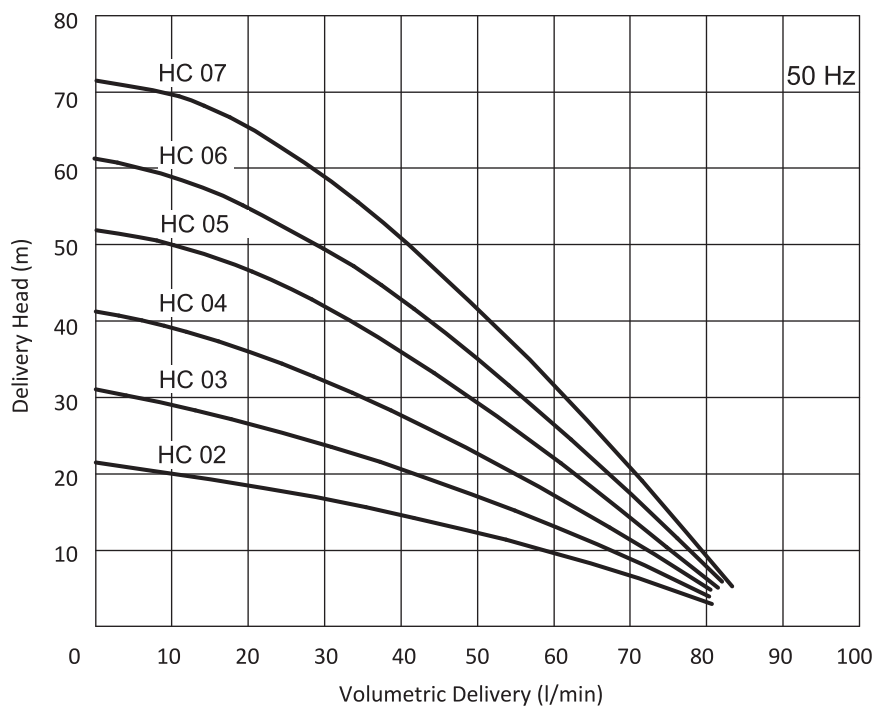



HCA PUMP

Applications:

- Cutting, turning, milling, boring, grinding and similar applications of the machine tools,
- Cooling systems,
- Circulation systems. HCA Pumps are used for pumping of cutting / cooling fluids.

Fluid Specifications:

- Coolants,
- Cutting oils,
- Grinding oils,
- Water,
- Fluid temperature 0...80 °C
- Kinematic viscosity 1...30 mm²/s

Materials:

Pump body	: Cast iron - DIN GG 25
Bottom plate	: Sheet iron
Diffuser	: Stainless steel - DIN 4301 (AISI 304)
Impeller	: Stainless steel - DIN 4301 (AISI 304)
Strainer	: Stainless steel - DIN 4301 (AISI 304)
Pump shaft	: Stainless steel - DIN 4401 (AISI 316)
O-ring	: Viton
Mechanical seal	: C - SiC - Viton TC - TC - Viton (Optional)
Electric motor	: 3 phase induction motor - 2 pole, Protection degree IP 55

DIMENSIONS & NOMINAL VALUES

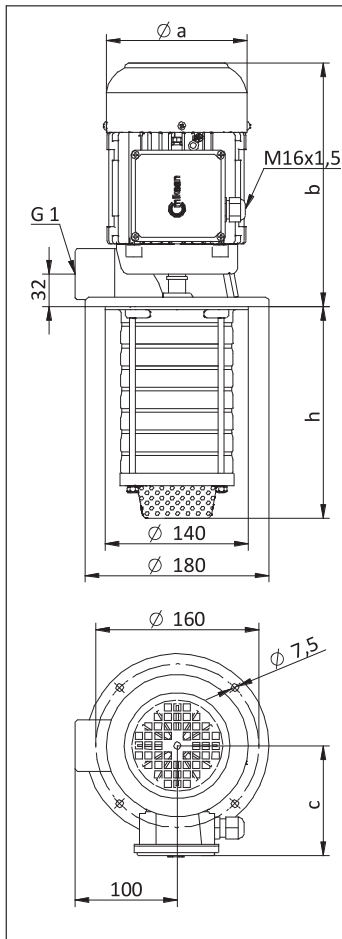

TYPE	Depth of immersion h (mm)	a	b	c	Weight kg	Power kW	Voltage V(Δ/Y)	Frequency Hz	Rated current A	Speed rpm
		mm								
HCA/02	143	138	240	111	10.1	0.37	230/400	50	1.84/1.05	2790
HCA/03	143				11.4	0.55			2.25/1.3	2780
HCA/04	164				13.3	0.75			3.12/1.8	2820
HCA/05	185				13.6	1.10			4.85/2.8	2720
HCA/06	206				13.8	1.10			4.85/2.8	2720
HCA/07	227				14.0	1.10			4.85/2.8	2720

* The performance curves are based on $1 \text{ mm}^2/\text{s}$ (cSt) kinematic viscosity values and 997 kg/m^3 density
 ** Curve tolerance according to ISO 9906:2012 Grade 3B.
 *** HCA/05, HCA/06 and HCA/07 pumps have IE2 motors. According to IEC 60034-30-1:2014 standard these pumps are excluded from efficiency class since their motors are completely integrated into the pump.

Performance Curve

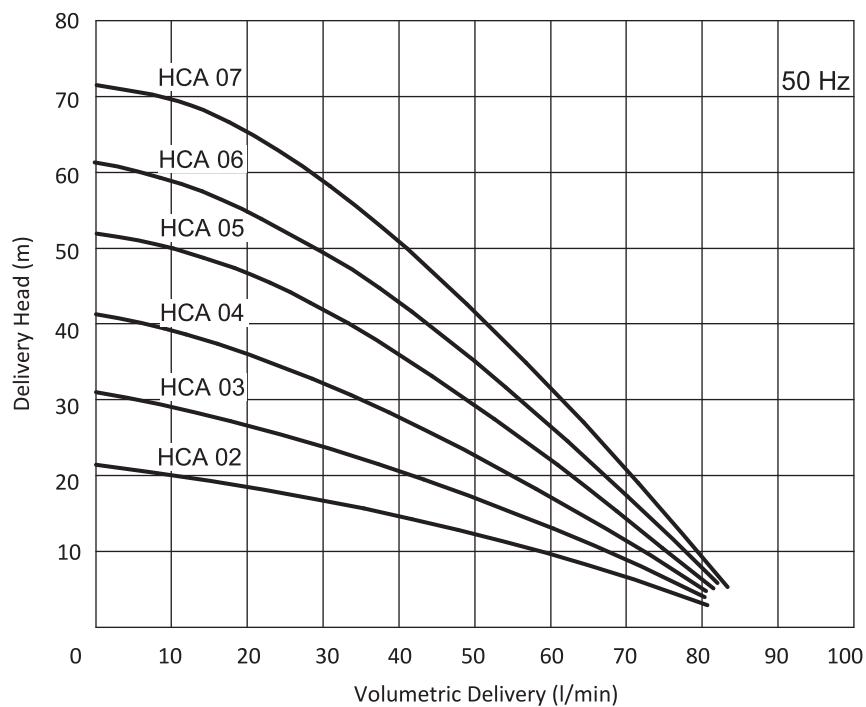



HCB PUMP

Applications:

- Cutting, turning, milling, boring, grinding and similar applications of the machine tools,
- Especially used for deep hole boring operations due to supply 25 bar pressure,
- Circulation systems. HCB Pumps are used for pumping of cutting / cooling fluids.

Fluid Specifications:

- Coolants,
- Cutting oils,
- Grinding oils,
- Water,
- Fluid temperature 0...80 °C
- Kinematic viscosity 1...30 mm²/s

Materials:

Pump body	: Cast iron - DIN GG 25
Bottom plate	: Sheet iron
Diffuser	: Stainless steel - DIN 4301 (AISI 304)
Impeller	: Stainless steel - DIN 4301 (AISI 304)
Strainer	: Stainless steel - DIN 4301 (AISI 304)
Pump shaft	: Stainless steel - DIN 4401 (AISI 316)
O-ring	: Viton
Mechanical seal	: C - SiC - Viton TC - TC - Viton (Optional)
Electric motor	: 3 phase induction motor IE3 - 2 pole, Protection degree IP 55

- * M16x1,5 cable gland is used on HCB/06 and HCB/08 pumps.
- ** The performance curves are based on 1 mm²/s (cSt) kinematic viscosity values and 997 kg/m³ density
- *** Curve tolerance according to ISO 9906:2012 Grade 3B.

DIMENSIONS & NOMINAL VALUES

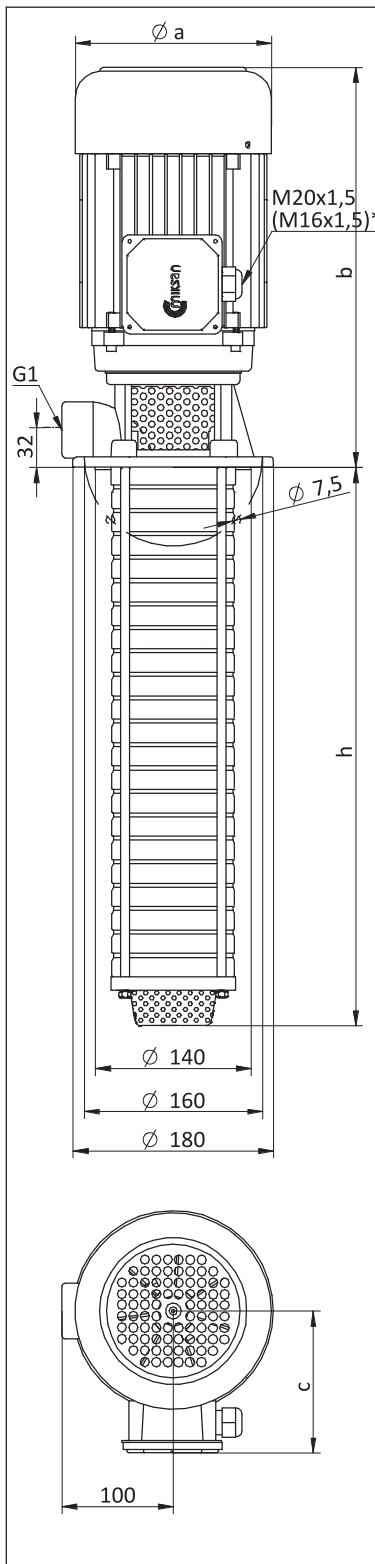

TYPE	Depth of immersion h (mm)	mm			Weight kg	Power kW	Voltage V(Δ/Y)	Frequency Hz	Rated current A	Speed rpm
		a	b	c						
HCB/06	206	157	319	118	17.0	1.1	230/400	50	4.16/2.4	2890
HCB/08	248	157	319	118	17.5	1.1	230/400		4.16/2.4	2890
HCB/10	291	176	365	139	25.0	2.2	230/400		7.79/4.5	2905
HCB/12	333	176	365	139	25.5	2.2	230/400		7.79/4.5	2905
HCB/15	396	194	397	150	33.0	3.0	230/400		10.39/6.0	2905
HCB/17	438	194	397	150	33.5	3.0	230/400		10.39/6.0	2905
HCB/20	501	194	397	150	37.0	4.0	230/400		13.68/7.9	2900
HCB/22	543	194	397	150	37.5	4.0	230/400		13.68/7.9	2900
HCB/25	606	194	397	150	39.5	4.0	230/400		13.68/7.9	2900

Performance Curve

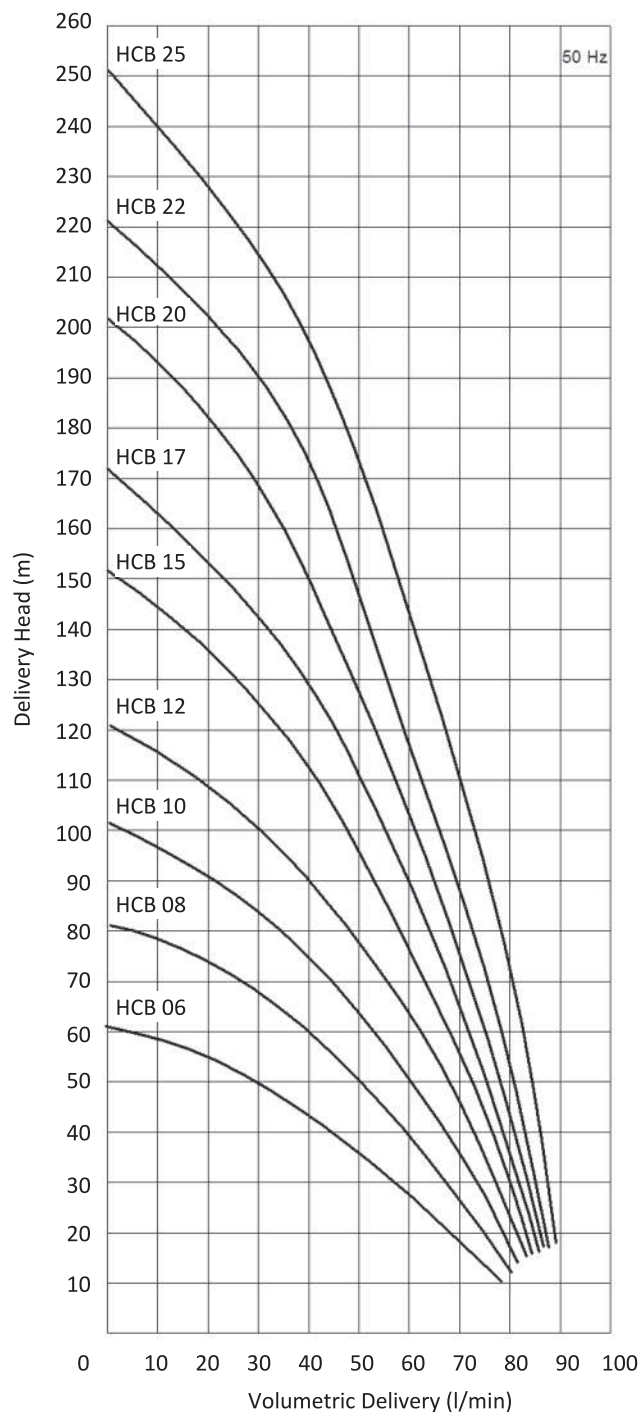



HD PUMP

Applications:

- Cutting, turning, milling, boring, grinding and similar applications of the machine tools,
- Erosion machines,
- Circulation systems. HD Pumps are used for pumping of cutting / cooling fluids.

Fluid Specifications:

- Coolants,
- Cutting oils,
- Grinding oils,
- Water,
- Fluid temperature 0...80 °C
- Kinematic viscosity 1...30 mm²/s

Materials:

Pump body	: Cast iron - DIN GG 25
Inlet body	: Cast iron - DIN GG 25
Diffuser	: Stainless steel - DIN 4301 (AISI 304)
Impeller	: Stainless steel - DIN 4301 (AISI 304)
Stage cover	: Stainless steel - DIN 4301 (AISI 304)
Pump shaft	: Stainless steel - DIN 4401 (AISI 316)
O-ring	: Viton
Mechanical seal	: C - SiC - Viton TC - TC - Viton (Optional)
Electric motor	: 3 phase induction motor - 2 pole, Protection degree IP 55

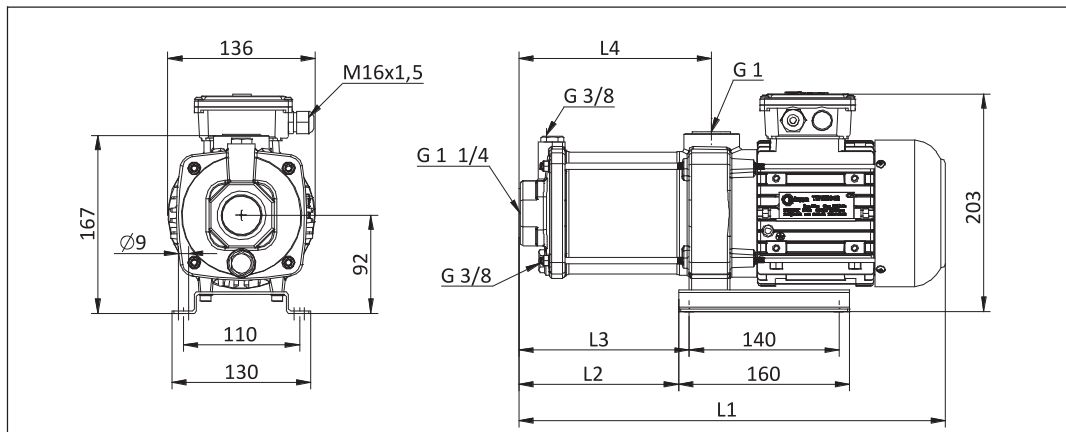

DIMENSIONS & NOMINAL VALUES

TYPE	L4	L3	L2	L1	Weight kg	Power kW	Voltage V(Δ/Y)	Frequency Hz	Rated current A	Speed rpm
	mm									
HD/02	137	116	106	356	12.9	0.55	230/400	50	2.25/1.3	2780
HD/03	158	137	127	377	13.1	0.55			2.25/1.3	2780
HD/04	179	158	148	398	14.9	1.1			4.85/2.8	2720
HD/05	200	179	169	419	15.1	1.1			4.85/2.8	2720
HD/06	221	200	190	440	15.3	1.1			4.85/2.8	2720

* The performance curves are based on 1 mm²/s (cSt) kinematic viscosity values and 997 kg/m³ density
 ** Curve tolerance according to ISO 9906:2012 Grade 3B.
 *** HD/04, HD/05 and HD/06 pumps have IE2 motors. According to IEC 60034-30-1:2014 standard these pumps are excluded from efficiency class since their motors are completely integrated into the pump.

Performance Curve

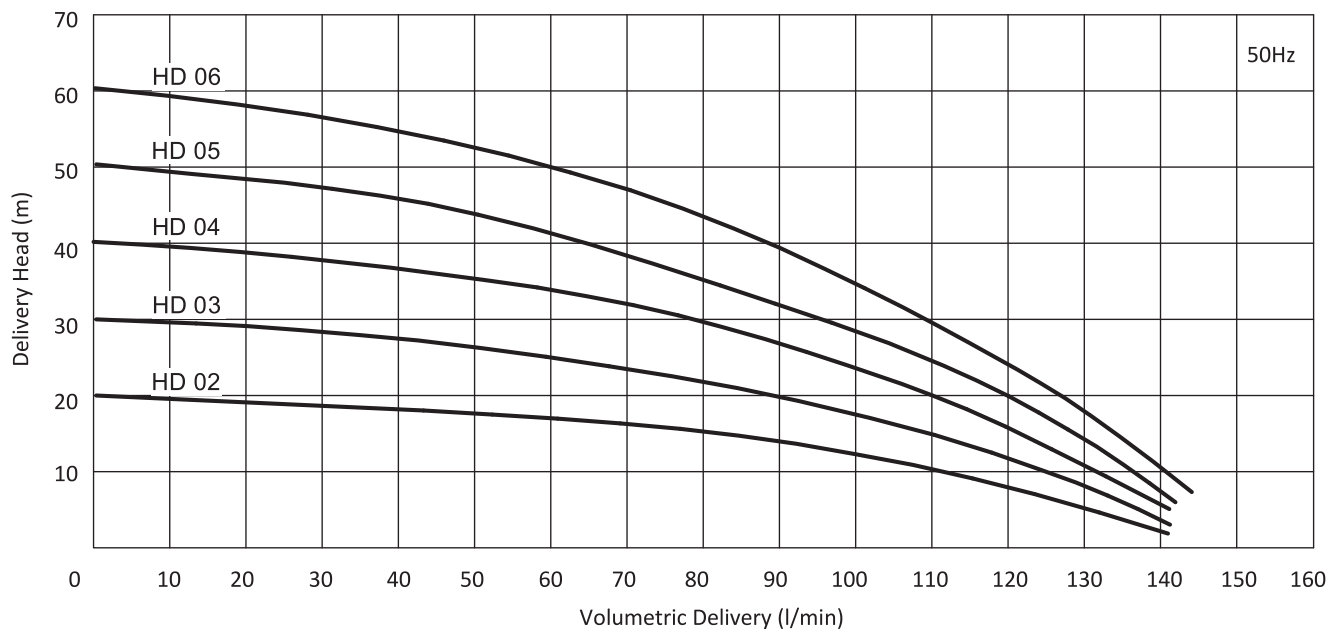



HDA PUMP

Applications:

- Cutting, turning, milling, boring, grinding and similar applications of the machine tools,
- Cooling systems,
- Circulation systems. HDA Pumps are used for pumping of cutting / cooling fluids.

Fluid Specifications:

- Coolants,
- Cutting oils,
- Grinding oils,
- Water,
- Fluid temperature 0...80 °C
- Kinematic viscosity 1...30 mm²/s

Materials:

Pump body	: Cast iron - DIN GG 25
Bottom plate	: Sheet iron
Diffuser	: Stainless steel - DIN 4301 (AISI 304)
Impeller	: Stainless steel - DIN 4301 (AISI 304)
Strainer	: Stainless steel - DIN 4301 (AISI 304)
Pump shaft	: Stainless steel - DIN 4401 (AISI 316)
O-ring	: Viton
Mechanical seal	: C - SiC - Viton TC - TC - Viton (Optional)
Electric motor	: 3 phase induction motor IE3 - 2 pole, Protection degree IP 55

DIMENSIONS & NOMINAL VALUES

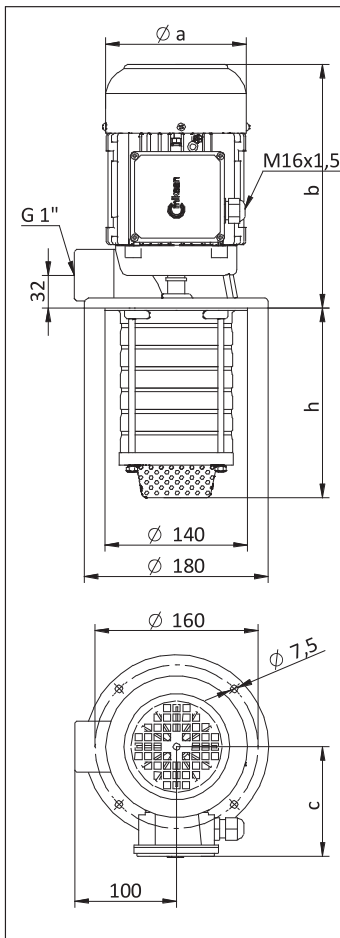

TYPE	Depth of immersion h (mm)	mm			Weight kg	Power kW	Voltage V(Δ/Y)	Frequency Hz	Rated current	
		a	b	c					A	rpm
HDA/02	143	138	240	111	11.2	0.55	230/400	50	2.25/1.3	2780
HDA/03	143				11.4	0.55	230/400		2.25/1.3	2780
HDA/04	164				13.4	1.1	230/400		4.85/2.8	2720
HDA/05	185				13.6	1.1	230/400		4.85/2.8	2720
HDA/06	206				13.8	1.1	230/400		4.85/2.8	2720

* The performance curves are based on 1 mm²/s (cSt) kinematic viscosity values and 997 kg/m³ density

** Curve tolerance according to ISO 9906:2012 Grade 3B.

*** HDA/04, HDA/05 and HDA/06 pumps have IE2 motors. According to IEC 60034-30-1:2014 standard these pumps are excluded from efficiency class since their motors are completely integrated into the pump.

Performance Curve

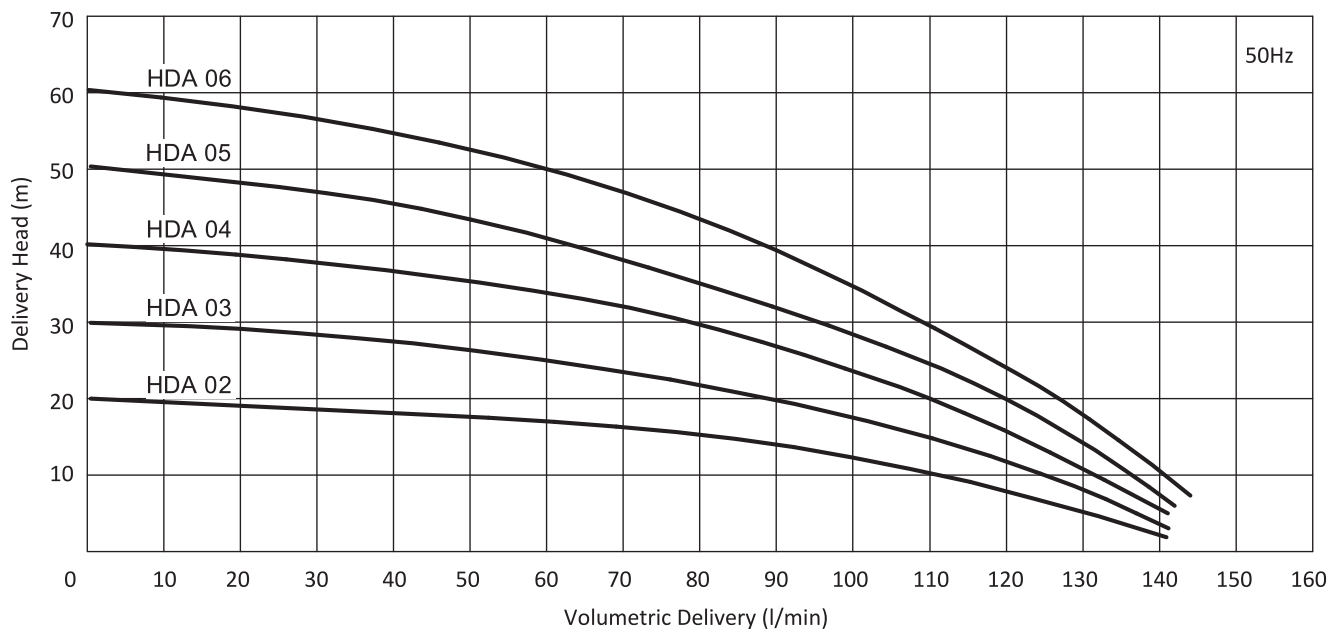



HDB PUMP

Applications:

- Cutting, turning, milling, boring, grinding and similar applications of the machine tools,
- Especially used for deep hole boring operations due to supply 25 bar pressure,
- Circulation systems. HDB Pumps are used for pumping of cutting / cooling fluids.

Fluid Specifications:

- Coolants,
- Cutting oils,
- Grinding oils,
- Water,
- Fluid temperature 0...80 °C
- Kinematic viscosity 1...30 mm²/s

Materials:

Pump body	: Cast iron - DIN GG 25
Bottom plate	: Sheet iron
Diffuser	: Stainless steel - DIN 4301 (AISI 304)
Impeller	: Stainless steel - DIN 4301 (AISI 304)
Strainer	: Stainless steel - DIN 4301 (AISI 304)
Pump shaft	: Stainless steel - DIN 4401 (AISI 316)
O-ring	: Viton
Mechanical seal	: C - SiC - Viton TC - TC - Viton (Optional)
Electric motor	: 3 phase induction motor IE3 - 2 pole, Protection degree IP 55

* M16x1,5 cable gland is used on HDB/06 pump.

** The performance curves are based on 1 mm²/s (cSt) kinematic viscosity values and 997 kg/m³ density

*** Curve tolerance according to ISO 9906:2012 Grade 3B.

DIMENSIONS & NOMINAL VALUES

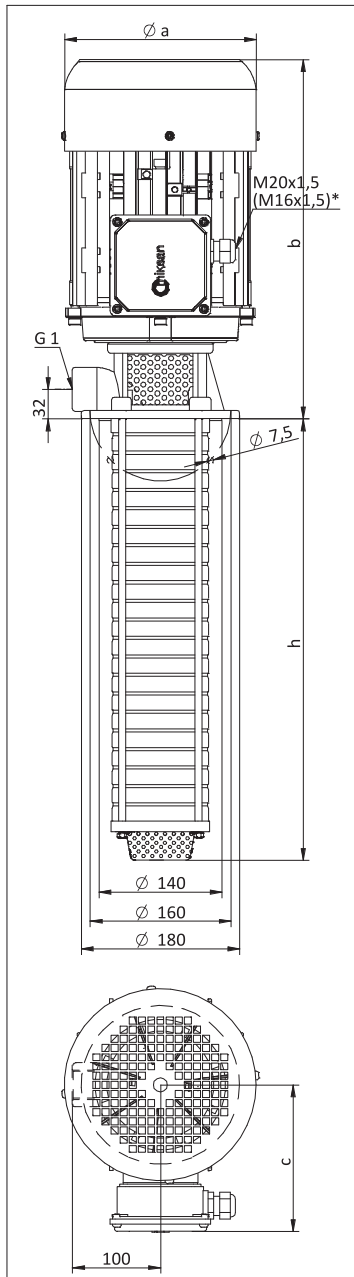

TYPE	Depth of immersion h (mm)	Dimensions (mm)			Weight (kg)	Power (kW)	Voltage V(Δ/Y)	Frequency (Hz)	Rated current (A)	Speed (rpm)
		a	b	c						
HDB/06	206	157	319	118	17.0	1.1	230/400	50	4.16/2.4	2890
HDB/08	248	176	340	139	21.5	1.5	230/400		5.72/3.3	2910
HDB/10	291	176	365	139	25.0	2.2	230/400		7.79/4.5	2905
HDB/12	333	194	397	150	32.0	3.0	230/400		10.39/6.0	2905
HDB/15	396	194	397	150	33.0	3.0	230/400		10.39/6.0	2905
HDB/17	438	194	397	150	36.0	4.0	230/400		13.68/7.9	2900
HDB/20	501	194	397	150	37.0	4.0	230/400		13.68/7.9	2900
HDB/22	543	218	406	163	41.5	5.5	230/400		17.15/9.9	2900
HDB/25	606	218	406	163	42.5	5.5	230/400		17.15/9.9	2900

Performance Curve

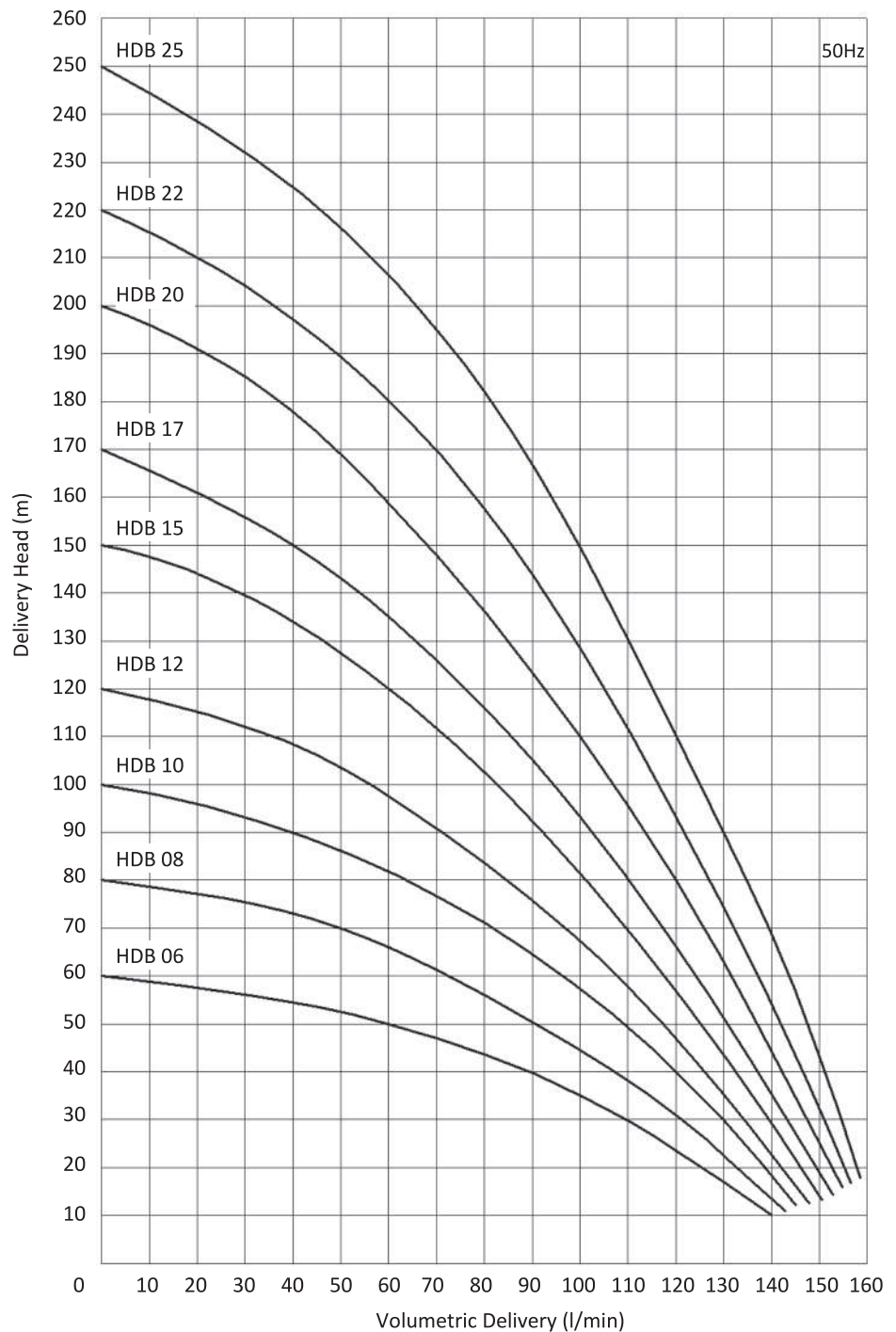



HEB PUMP

Applications:

- Cutting, turning, milling, boring, grinding and similar applications of the machine tools,
- Especially used for deep hole boring operations due to supply 23,5 bar pressure,
- Circulation systems. HEB Pumps are used for pumping of cutting / cooling fluids.

Fluid Specifications:

- Coolants,
- Cutting oils,
- Grinding oils,
- Water,
- Fluid temperature 0...80 °C
- Kinematic viscosity 1...30 mm²/s

Materials:

Pump body	: Cast iron - DIN GG 25
Bottom plate	: Cast iron - DIN GG 25
Diffuser	: Stainless steel - DIN 4301 (AISI 304)
Impeller	: Stainless steel - DIN 4301 (AISI 304)
Strainer	: Stainless steel - DIN 4301 (AISI 304)
Pump shaft	: Stainless steel - DIN 4401 (AISI 316)
O-ring	: Viton
Mechanical seal	: C - SiC - Viton TC - TC - Viton (Optional)
Electric motor	: 3 phase induction motor IE3 - 2 pole, Protection degree IP 55

* M16x1,5 cable gland is used on HEB 02 pump.

** M25x1,5 cable gland is used on HEB 14 to HEB 20 pumps.

*** The performance curves are based on 1 mm²/s (cSt) kinematic viscosity values and 997 kg/m³ density

**** Curve tolerance according to ISO 9906:2012 GRADE 3B.

DIMENSIONS & NOMINAL VALUES

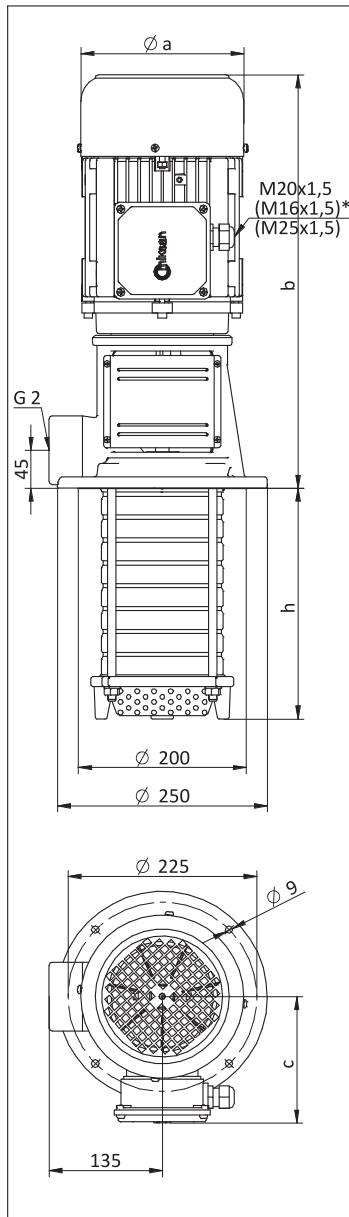

TYPE	Depth of immersion h (mm)	mm			Weight kg	Power kW	Voltage V(Δ/Y)	Frequency Hz	Rated current	
		a	b	c					A	rpm
HEB 02	167	157	415	118	24.5	1.1	230/400	50	4.16/2.4	2890
HEB 03	167	176	437	139	28.5	1.5	230/400		5.72/3.3	2910
HEB 04	194	176	462	139	32.0	2.2	230/400		7.79/4.5	2905
HEB 05	221	194	489	150	38.5	3.0	230/400		10.39/6.0	2905
HEB 06	248	194	489	150	39.0	3.0	230/400		10.39/6.0	2905
HEB 07	275	194	489	150	39.5	3.0	230/400		10.39/6.0	2905
HEB 08	302	194	489	150	43.0	4.0	230/400		13.68/7.9	2900
HEB 10	356	218	502	163	49.5	5.5	230/400		17.15/9.9	2900
HEB 12	410	218	502	163	50.5	5.5	230/400		17.15/9.9	2900
HEB 14	464	258	618	177	79.0	7.5	400 Δ		14.0	2930
HEB 16	518	258	618	177	80.0	7.5	400 Δ		14.0	2930
HEB 18	572	258	618	177	81.0	7.5	400 Δ		14.0	2930
HEB 20	626	258	618	177	92.0	11.0	400 Δ		19.7	2930

Performance Curve

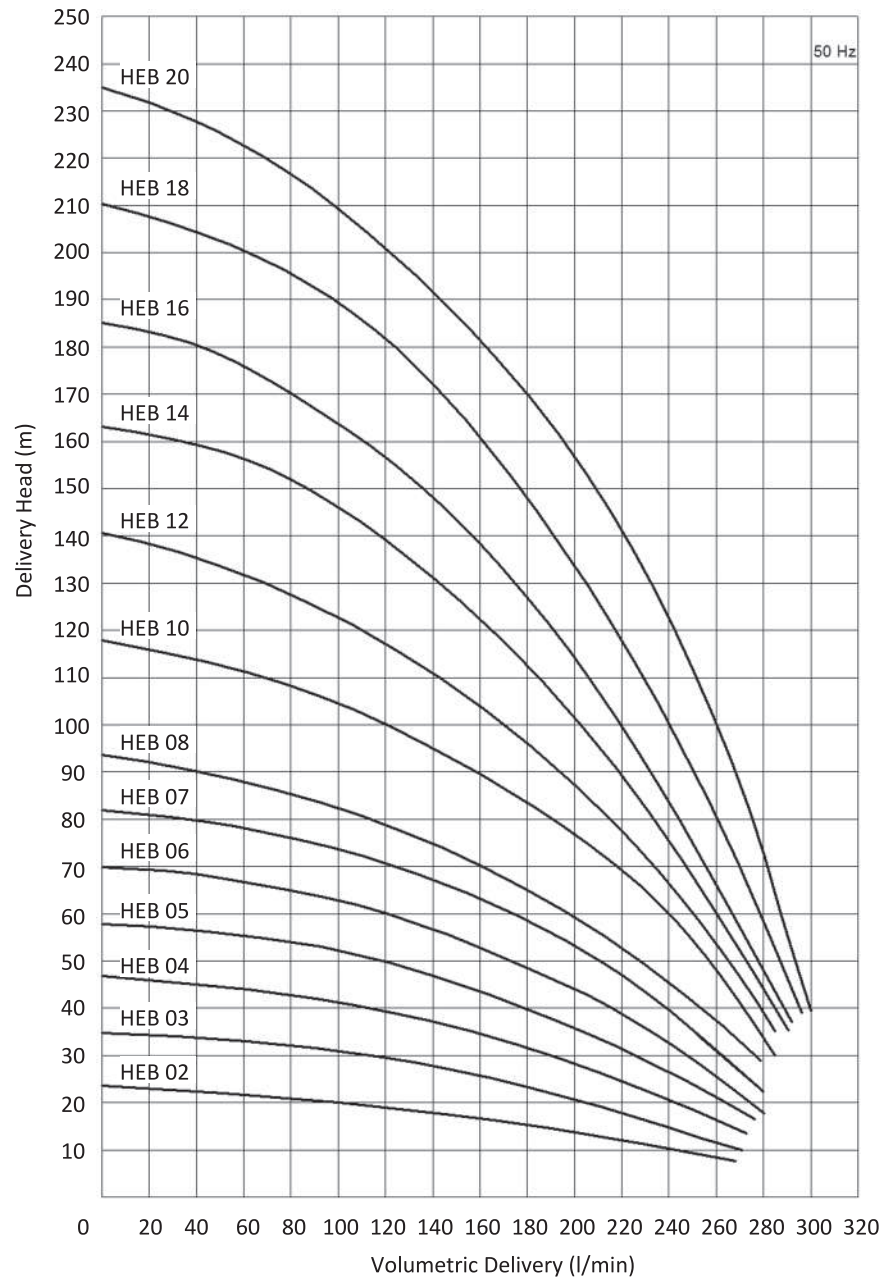



HCD PUMP

Applications:

- Cutting, turning, milling, boring, grinding and similar applications of the machine tools,
- Especially used for deep hole boring operations due to supply 25 bar pressure,
- Circulation systems. HCD Pumps are used for pumping of cutting / cooling fluids.

Fluid Specifications:

- Coolants,
- Cutting oils,
- Grinding oils,
- Water,
- Fluid temperature 0...80 °C
- Kinematic viscosity 1...30 mm²/s

Materials:

Pump body	: Cast iron - DIN GG 25
Cover	: Cast iron - DIN GG 25
Diffuser	: Stainless steel - DIN 4301 (AISI 304)
Impeller	: Stainless steel - DIN 4301 (AISI 304)
Strainer	: Stainless steel - DIN 4301 (AISI 304)
Pump shaft	: Stainless steel - DIN 4401 (AISI 316)
O-ring	: Viton
Mechanical seal	: C - SiC - Viton TC - TC - Viton (Optional)
Electric motor	: 3 phase induction motor IE3 - 2 pole, Protection degree IP 55

* M16x1,5 cable gland is used on HCD/08 pump.

** The performance curves are based on 1 mm²/s (cSt) kinematic viscosity values and 997 kg/m³ density

*** Curve tolerance according to ISO 9906:2012 Grade 3B.

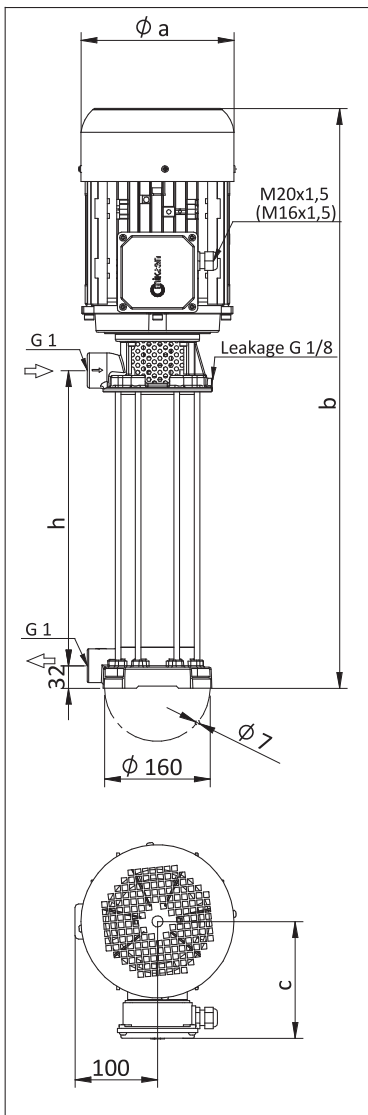

DIMENSIONS & NOMINAL VALUES

TYPE	Length h (mm)	Length			Weight kg	Power kW	Voltage V(Δ/Y)	Frequency Hz	Rated current A	Speed rpm
		a	b	c						
HCD/08	316	157	634	118	22.0	1.1	230/400	50	4.16/2.4	2890
HCD/10	316	176	680	139	29.0	2.2	230/400		7.79/4.5	2905
HCD/12	420	176	784	139	31.0	2.2	230/400		7.79/4.5	2905
HCD/15	420	194	816	150	37.5	3.0	230/400		10.39/6.0	2905
HCD/17	524	194	920	150	39.5	3.0	230/400		10.39/6.0	2905
HCD/20	524	194	920	150	42.5	4.0	230/400		13.68/7.9	2900
HCD/22	628	194	1024	150	44.5	4.0	230/400		13.68/7.9	2900
HCD/25	628	194	1024	150	45.0	4.0	230/400		13.68/7.9	2900

Performance Curve

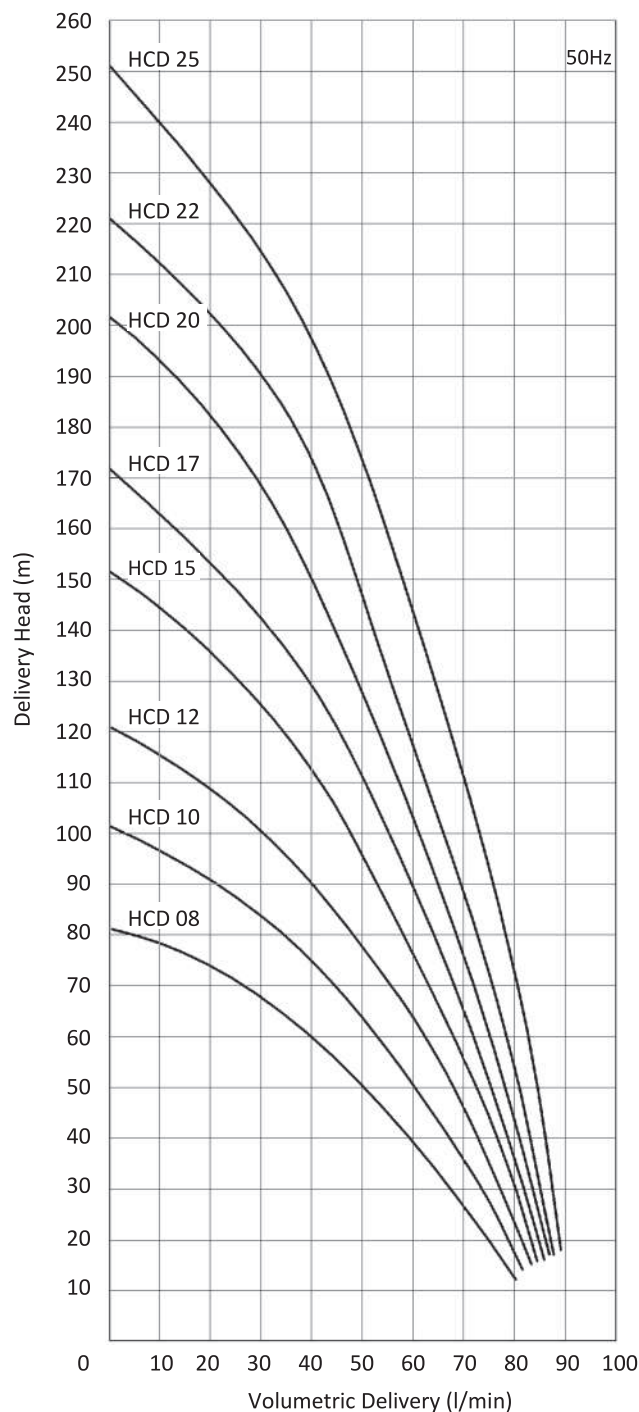



HDD PUMP

Applications:

- Cutting, turning, milling, boring, grinding and similar applications of the machine tools,
- Especially used for deep hole boring operations due to supply 25 bar pressure,
- Circulation systems. HDD Pumps are used for pumping of cutting / cooling fluids.

Fluid Specifications:

- Coolants,
- Cutting oils,
- Grinding oils,
- Water,
- Fluid temperature 0...80 °C
- Kinematic viscosity 1...30 mm²/s

Materials:

Pump body	: Cast iron - DIN GG 25
Cover	: Cast iron - DIN GG 25
Diffuser	: Stainless steel - DIN 4301 (AISI 304)
Impeller	: Stainless steel - DIN 4301 (AISI 304)
Strainer	: Stainless steel - DIN 4301 (AISI 304)
Pump shaft	: Stainless steel - DIN 4401 (AISI 316)
O-ring	: Viton
Mechanical seal	: C - SiC - Viton TC - TC - Viton (Optional)
Electric motor	: 3 phase induction motor IE3 - 2 pole, Protection degree IP 55

- * M16x1,5 cable gland is used on HDD/08 pump.
 ** The performance curves are based on 1 mm²/s (cSt) kinematic viscosity values and 997 kg/m³ density
 *** Curve tolerance according to ISO 9906:2012 Grade 3B.

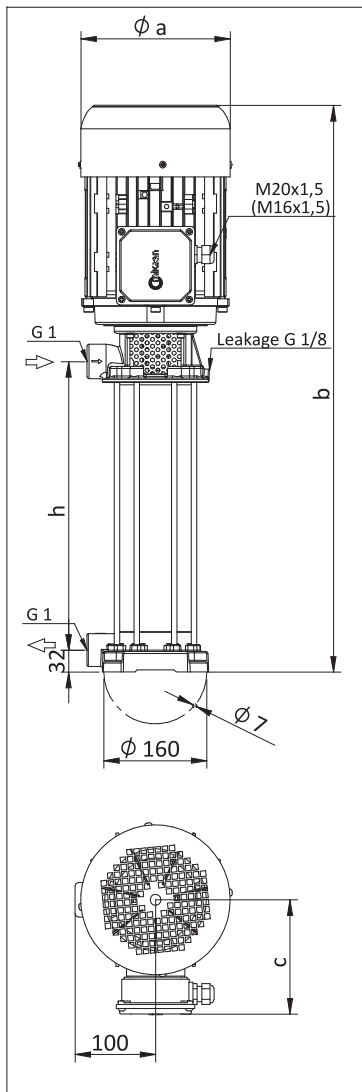

DIMENSIONS & NOMINAL VALUES

TYPE	Length			Weight kg	Power kW	Voltage V(Δ/Y)	Frequency Hz	Rated current A	Speed rpm	
	h (mm)	a	b							c
HDD/08	316	176	655	139	26.0	1.5	230/400	50	5.72/3.3	2910
HDD/10	316	176	680	139	29.0	2.2	230/400		7.79/4.5	2905
HDD/12	420	194	816	150	37.5	3.0	230/400		10.39/6.0	2905
HDD/15	420	194	816	150	38.0	3.0	230/400		10.39/6.0	2905
HDD/17	524	194	920	150	42.0	4.0	230/400		13.68/7.9	2900
HDD/20	524	194	920	150	42.5	4.0	230/400		13.68/7.9	2900
HDD/22	628	218	1024	163	49.5	5.5	230/400		17.15/9.9	2900
HDD/25	628	218	1024	163	50.0	5.5	230/400		17.15/9.9	2900

Performance Curve

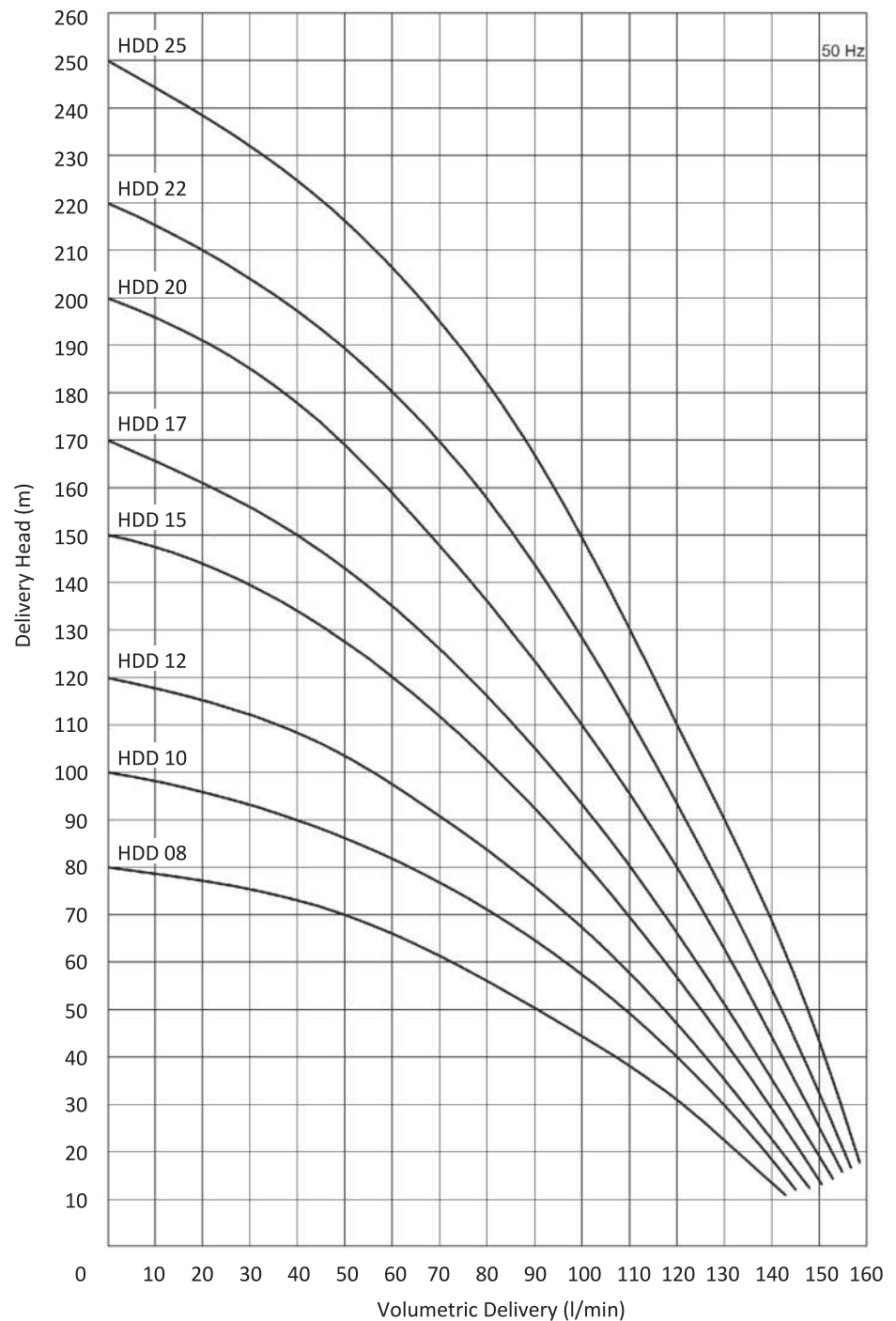



HED PUMP

Applications:

- Cutting, turning, milling, boring, grinding and similar applications of the machine tools,
- Especially used for deep hole boring operations due to supply 23,5 bar pressure,
- Circulation systems. HED Pumps are used for pumping of cutting / cooling fluids.

Fluid Specifications:

- Coolants,
- Cutting oils,
- Grinding oils,
- Water,
- Fluid temperature 0...80 °C
- Kinematic viscosity 1...30 mm²/s

Materials:

Pump body	: Cast iron - DIN GG 25
Cover	: Cast iron - DIN GG 25
Diffuser	: Stainless steel - DIN 4301 (AISI 304)
Impeller	: Stainless steel - DIN 4301 (AISI 304)
Strainer	: Stainless steel - DIN 4301 (AISI 304)
Pump shaft	: Stainless steel - DIN 4401 (AISI 316)
O-ring	: Viton
Mechanical seal	: C - SiC - Viton TC - TC - Viton (Optional)
Electric motor	: 3 phase induction motor IE3 - 2 pole, Protection degree IP 55

* M16x1,5 cable gland is used on HED 02 and HED 03 pumps.

** M25x1,5 cable gland is used on HED 16, HED 18 and HED 20 pumps.

*** The performance curves are based on 1 mm²/s (cSt) kinematic viscosity values and 997 kg/m³ density

**** Curve tolerance according to ISO 9906:2012 Grade 3B.

DIMENSIONS & NOMINAL VALUES

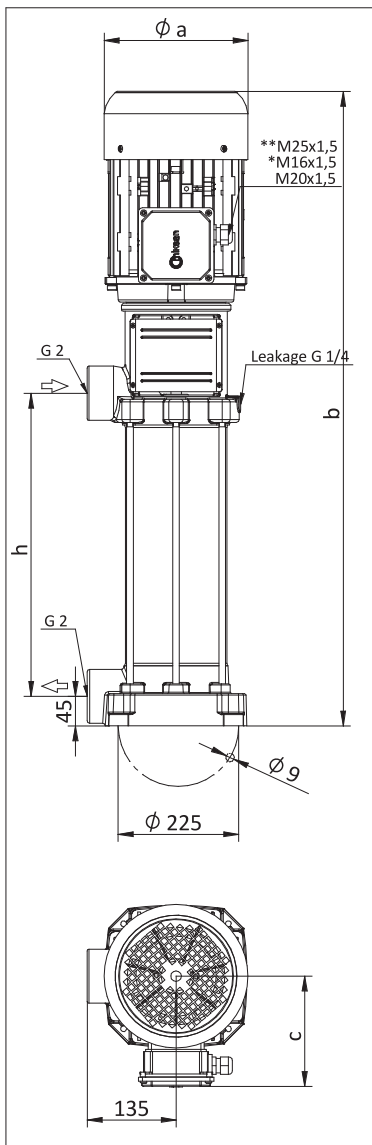

TYPE	Length			Weight kg	Power kW	Voltage V(Δ /Y)	Frequency Hz	Rated current A	Speed rpm	
	h (mm)	a	b							c
HED 02	269	157	683	118	32.0	1.1	230/400	50	4.16/2.4	2890
HED 03	269	176	705	139	36.0	1.5	230/400		5.72/3.3	2910
HED 04	269	176	730	139	39.5	2.2	230/400		7.79/4.5	2905
HED 05	269	194	771	150	46.0	3.0	230/400		10.39/6.0	2905
HED 06	350	194	852	150	47.5	3.0	230/400		10.39/6.0	2905
HED 07	350	194	852	150	48.0	3.0	230/400		10.39/6.0	2905
HED 08	350	194	852	150	51.0	4.0	230/400		13.68/7.9	2900
HED 10	460	218	1074	163	59.0	5.5	230/400		17.15/9.9	2900
HED 12	460	218	1074	163	59.5	5.5	230/400		17.15/9.9	2900
HED 14	568	258	1186	177	89.5	7.5	400 Δ		14.0	2940
HED 16	568	258	1186	177	90.0	7.5	400 Δ		14.0	2940
HED 18	676	258	1294	177	93.0	7.5	400 Δ		14.0	2940
HED 20	676	258	1294	177	103.0	11.0	400 Δ		19.7	2930

Performance Curve

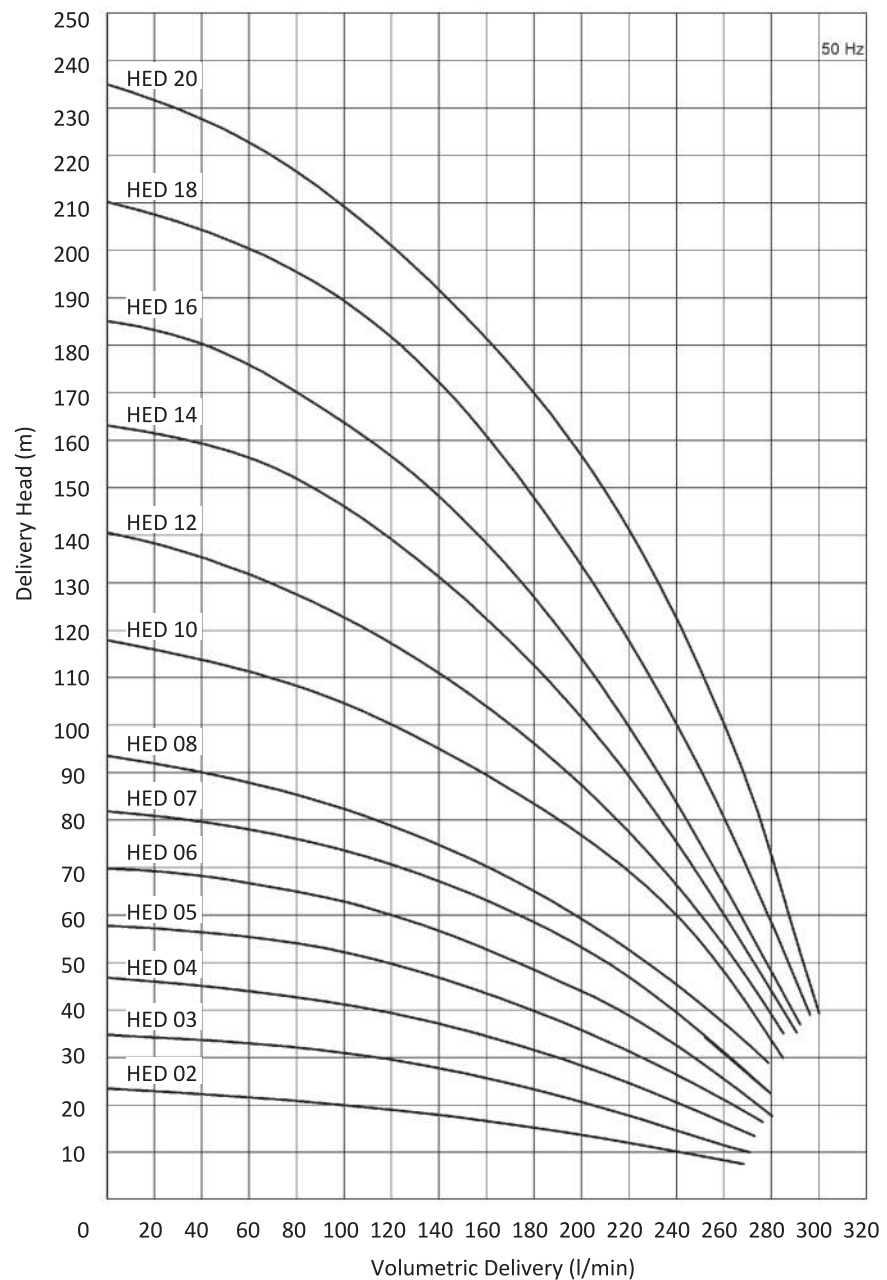



HC PUMP

60 Hz

Applications:

- Cutting, turning, milling, boring, grinding and similar applications of the machine tools,
- Erosion machines,
- Circulation systems. HC Pumps are used for pumping of cutting / cooling fluids.

Fluid Specifications:

- Coolants,
- Cutting oils,
- Grinding oils,
- Water,
- Fluid temperature 0...80 °C
- Kinematic viscosity 1...30 mm²/s

Materials:

Pump body	: Cast iron - DIN GG 25
Inlet body	: Cast iron - DIN GG 25
Diffuser	: Stainless steel - DIN 4301 (AISI 304)
Impeller	: Stainless steel - DIN 4301 (AISI 304)
Stage cover	: Stainless steel - DIN 4301 (AISI 304)
Pump shaft	: Stainless steel - DIN 4401 (AISI 316)
O-ring	: Viton
Mechanical seal	: C - SiC - Viton TC - TC - Viton (Optional)
Electric motor	: 3 phase induction motor - 2 pole, Protection degree IP 55

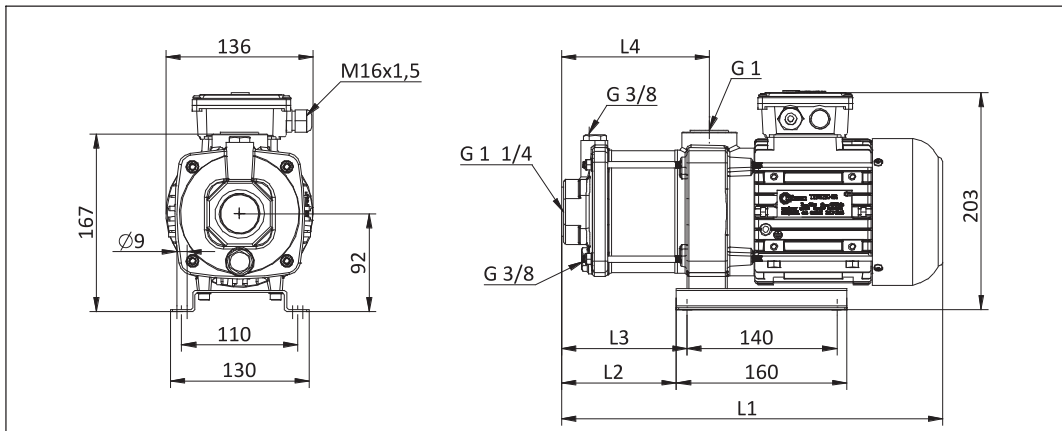

DIMENSIONS & NOMINAL VALUES

TYPE	L4	L3	L2	L1	Weight kg	Power kW	Voltage V(Δ/Y)	Frequency Hz	Rated current A	Speed rpm
	mm									
HC/02	137	116	106	356	11.8	0.44	265/460	60	1.82/1.05	3340
HC/03	158	137	127	377	13.1	0.66			2.25/1.3	3330
HC/04	179	158	148	398	15.0	0.90			3.12/1.8	3380
HC/05	200	179	169	419	15.1	1.3			4.85/2.8	3260
HC/06	221	200	190	440	15.3	1.3			4.85/2.8	3260

* The performance curves are based on 1 mm²/s (cSt) kinematic viscosity values and 997 kg/m³ density
 ** Curve tolerance according to ISO 9906:2012 Grade 3B.
 *** HC/05 and HC/06 pumps have IE2 motors. According to IEC 60034-30-1:2014 standard these pumps are excluded from efficiency class since their motors are completely integrated into the pump.

Performance Curve

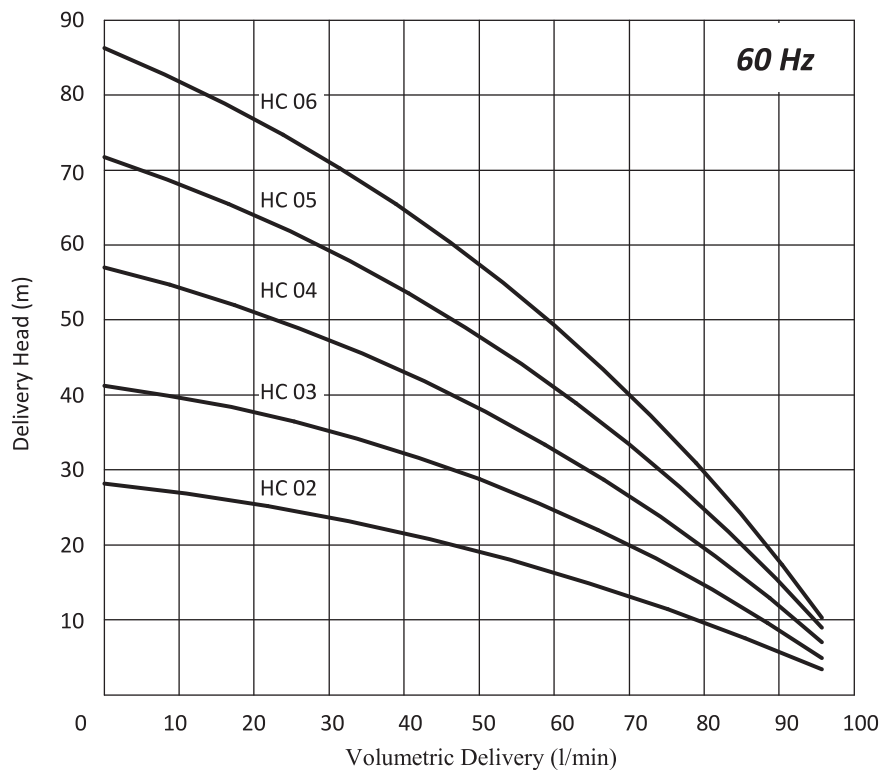



60 Hz

HCA PUMP

Applications:

- Cutting, turning, milling, boring, grinding and similar applications of the machine tools,
- Cooling systems,
- Circulation systems. HCA Pumps are used for pumping of cutting / cooling fluids.

Fluid Specifications:

- Coolants,
- Cutting oils,
- Grinding oils,
- Water,
- Fluid temperature 0...80 °C
- Kinematic viscosity 1...30 mm²/s

Materials:

Pump body	: Cast iron - DIN GG 25
Bottom plate	: Sheet iron
Diffuser	: Stainless steel - DIN 4301 (AISI 304)
Impeller	: Stainless steel - DIN 4301 (AISI 304)
Strainer	: Stainless steel - DIN 4301 (AISI 304)
Pump shaft	: Stainless steel - DIN 4401 (AISI 316)
O-ring	: Viton
Mechanical seal	: C - SiC - Viton TC - TC - Viton (Optional)
Electric motor	: 3 phase induction motor - 2 pole, Protection degree IP 55

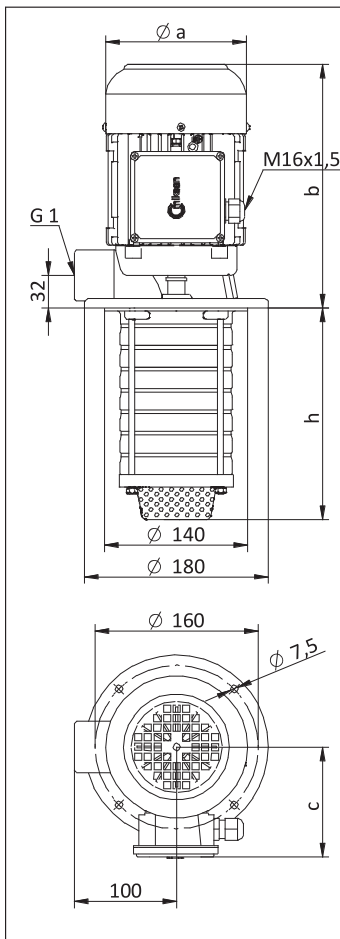
DIMENSIONS & NOMINAL VALUES

TYPE	Depth of immersion h (mm)	mm			Weight kg	Power kW	Voltage V(Δ/Y)	Frequency Hz	Rated current A	Speed rpm
		a	b	c						
HCA/02	143	138	240	111	10.1	0.44	265/460	60	1.82/1.05	3340
HCA/03	143				11.4	0.66			2.25/1.3	3330
HCA/04	164				13.3	0.90			3.12/1.8	3380
HCA/05	185				13.6	1.32			4.85/2.8	3260
HCA/06	206				13.8	1.32			4.85/2.8	3260

* The performance curves are based on $1 \text{ mm}^2/\text{s}$ (cSt) kinematic viscosity values and $997 \text{ kg}/\text{m}^3$ density
 ** Curve tolerance according to ISO 9906:2012 Grade 3B.
 *** HCA/05 and HCA/06 pumps have IE2 motors. According to IEC 60034-30-1:2014 standard these pumps are excluded from efficiency class since their motors are completely integrated into the pump.

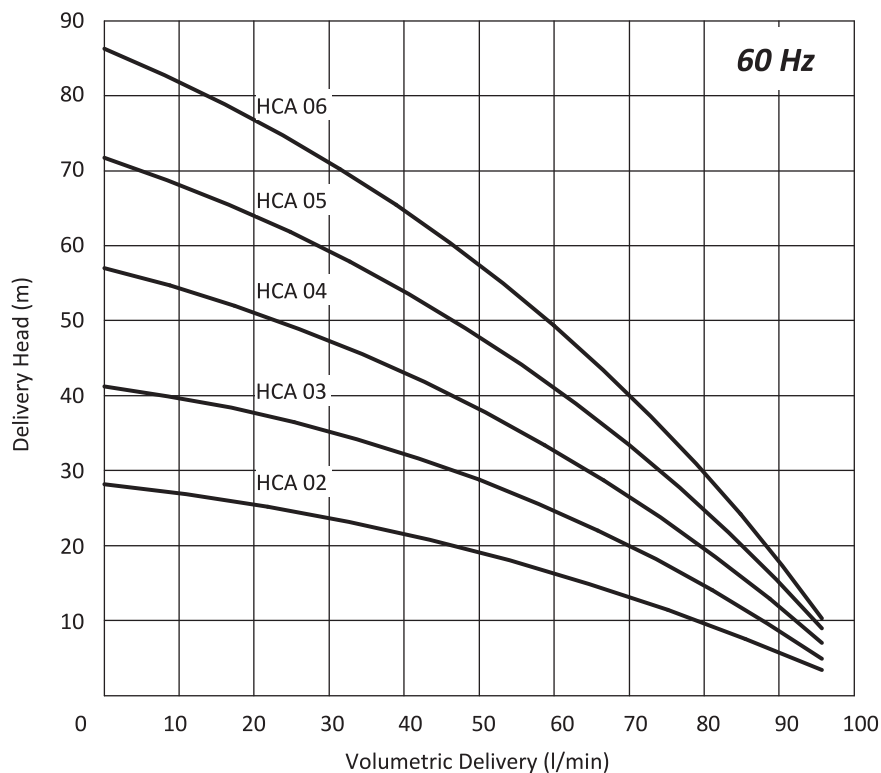
Performance Curve



HC B PUMP

Applications:

- Cutting, turning, milling, boring, grinding and similar applications of the machine tools,
- Especially used for deep hole boring operations due to supply 25 bar pressure,
- Circulation systems. HCB Pumps are used for pumping of cutting / cooling fluids.

Fluid Specifications:

- Coolants,
- Cutting oils,
- Grinding oils,
- Water,
- Fluid temperature 0...80 °C
- Kinematic viscosity 1...30 mm²/s

Materials:

Pump body	: Cast iron - DIN GG 25
Bottom plate	: Sheet iron
Diffuser	: Stainless steel - DIN 4301 (AISI 304)
Impeller	: Stainless steel - DIN 4301 (AISI 304)
Strainer	: Stainless steel - DIN 4301 (AISI 304)
Pump shaft	: Stainless steel - DIN 4401 (AISI 316)
O-ring	: Viton
Mechanical seal	: C - SiC - Viton TC - TC - Viton (Optional)
Electric motor	: 3 phase induction motor IE3 - 2 pole, Protection degree IP 55

- * M16x1,5 cable gland is used on HCB/06 and HCB/08 pumps.
- ** The performance curves are based on 1 mm²/s (cSt) kinematic viscosity values and 997 kg/m³ density
- *** Curve tolerance according to ISO 9906:2012 Grade 3B.

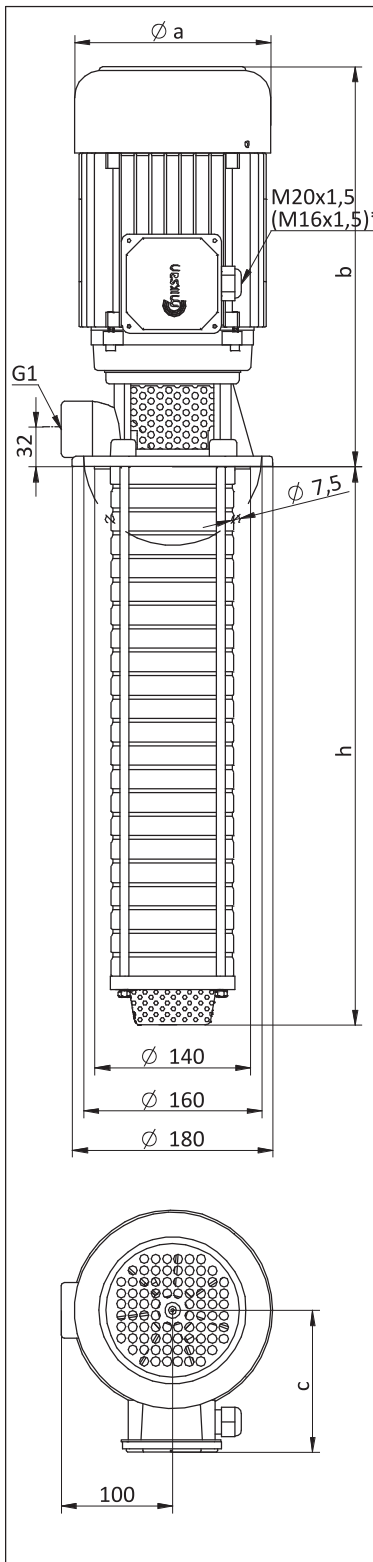
DIMENSIONS & NOMINAL VALUES

TYPE	Depth of immersion h (mm)	mm			Weight kg	Power kW	Voltage V(Δ/Y)	Frequency Hz	Rated current A	Speed rpm
		a	b	c						
HCB/06	206	157	319	118	17.0	1.3	265/460	60	4.35/2.5	3470
HCB/08	248	176	365	139	21.5	1.8			5.72/3.3	3490
HCB/10	291	176	365	139	25.0	2.65			7.79/4.5	3490
HCB/12	333	194	397	150	32.0	3.6			10.4/6.0	3495
HCB/15	396	194	397	150	33.0	3.6			10.4/6.0	3495
HCB/17	438	194	397	150	36.0	4.8			13.5/7.8	3485

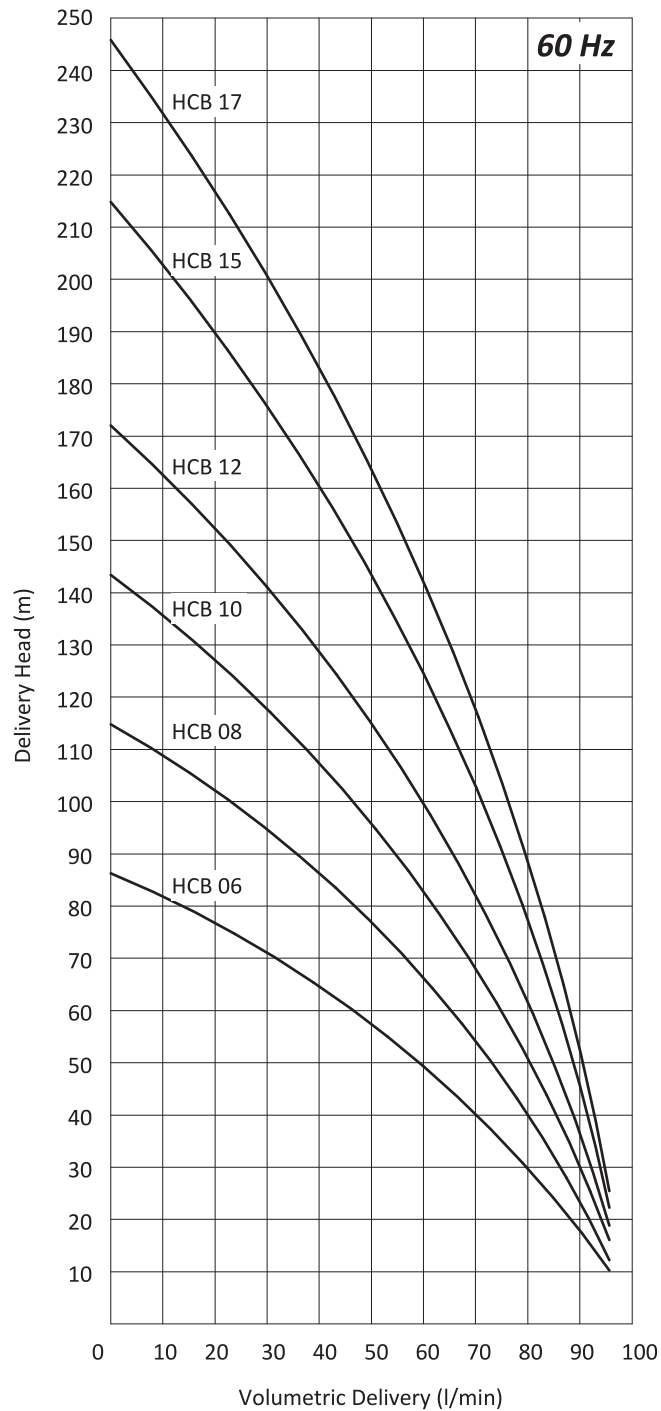
Performance Curve



HD PUMP

60 Hz

Applications:

- Cutting, turning, milling, boring, grinding and similar applications of the machine tools,
- Erosion machines,
- Circulation systems. HD Pumps are used for pumping of cutting / cooling fluids.

Fluid Specifications:

- Coolants,
- Cutting oils,
- Grinding oils,
- Water,
- Fluid temperature 0...80 °C
- Kinematic viscosity 1...30 mm²/s

Materials:

Pump body	: Cast iron - DIN GG 25
Inlet body	: Cast iron - DIN GG 25
Diffuser	: Stainless steel - DIN 4301 (AISI 304)
Impeller	: Stainless steel - DIN 4301 (AISI 304)
Stage cover	: Stainless steel - DIN 4301 (AISI 304)
Pump shaft	: Stainless steel - DIN 4401 (AISI 316)
O-ring	: Viton
Mechanical seal	: C - SiC - Viton TC - TC - Viton (Optional)
Electric motor	: 3 phase induction motor - 2 pole, Protection degree IP 55

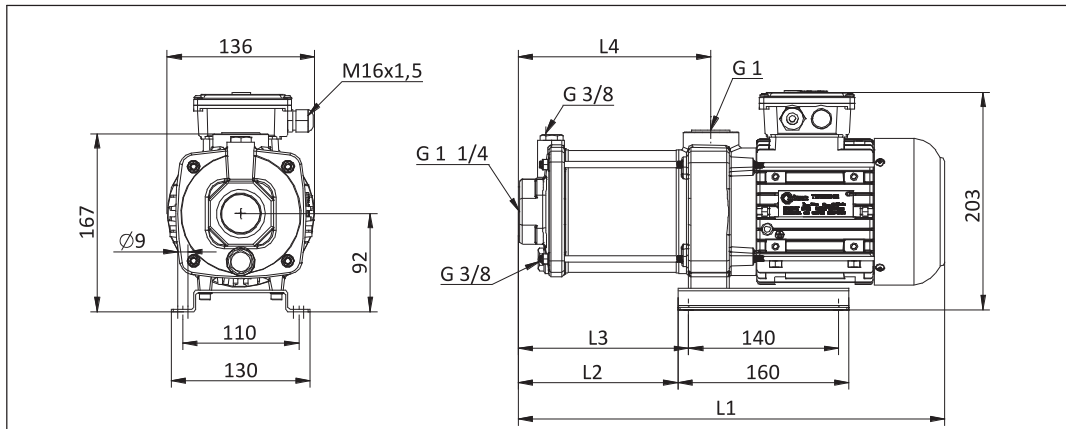
DIMENSIONS & NOMINAL VALUES

TYPE	L4	L3	L2	L1	Weight kg	Power kW	Voltage V(Δ/Y)	Frequency Hz	Rated current A	Speed rpm
	mm									
HD/02	137	116	106	356	13.5	0.66	265/460	60	2.25/1.3	3330
HD/03	158	137	127	377	14.5	1.32			4.85/2.8	3260
HD/04	179	158	148	398	14.9	1.32			4.85/2.8	3260

* The performance curves are based on 1 mm²/s (cSt) kinematic viscosity values and 997 kg/m³ density
 ** Curve tolerance according to ISO 9906:2012 Grade 3B.
 *** HD/03 and HD/04 pumps have IE2 motors. According to IEC 60034-30-1:2014 standard these pumps are excluded from efficiency class since their motors are completely integrated into the pump.

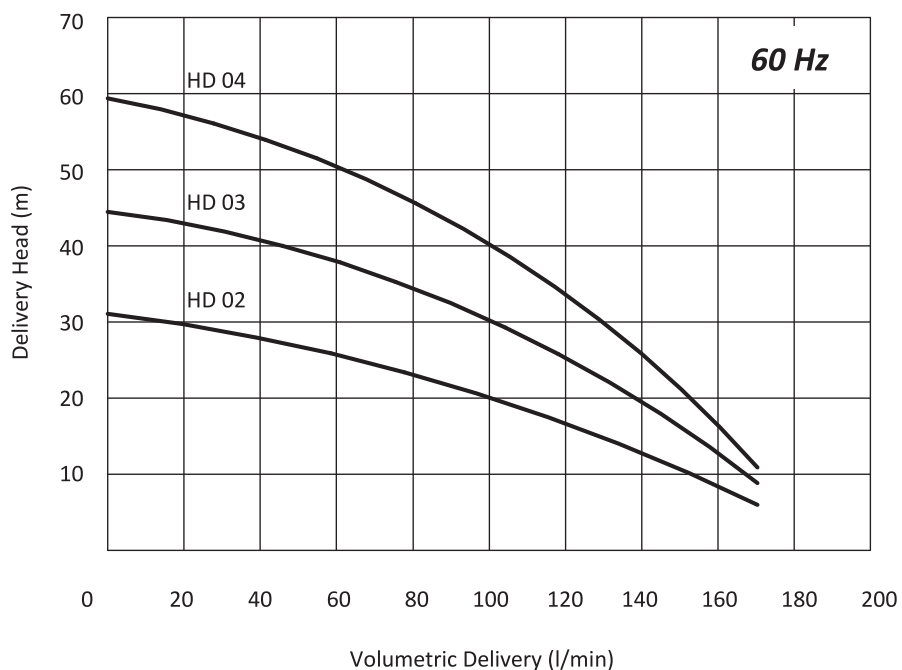
Performance Curve



60 Hz

HDA PUMP

Applications:

- Cutting, turning, milling, boring, grinding and similar applications of the machine tools,
- Cooling systems,
- Circulation systems. HDA Pumps are used for pumping of cutting / cooling fluids.

Fluid Specifications:

- Coolants,
- Cutting oils,
- Grinding oils,
- Water,
- Fluid temperature 0...80 °C
- Kinematic viscosity 1...30 mm²/s

Materials:

Pump body	: Cast iron - DIN GG 25
Bottom plate	: Sheet iron
Diffuser	: Stainless steel - DIN 4301 (AISI 304)
Impeller	: Stainless steel - DIN 4301 (AISI 304)
Strainer	: Stainless steel - DIN 4301 (AISI 304)
Pump shaft	: Stainless steel - DIN 4401 (AISI 316)
O-ring	: Viton
Mechanical seal	: C - SiC - Viton TC - TC - Viton (Optional)
Electric motor	: 3 phase induction motor IE3 - 2 pole, Protection degree IP 55

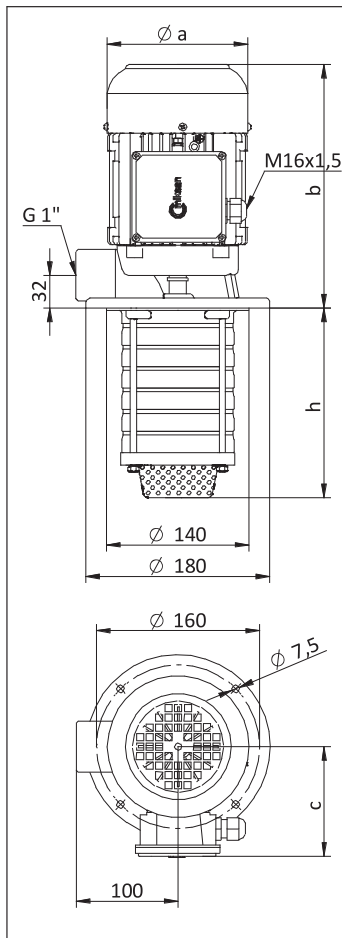
DIMENSIONS & NOMINAL VALUES

TYPE	Depth of immersion h (mm)	mm			Weight kg	Power kW	Voltage V(Δ/Y)	Frequency Hz	Speed	
		a	b	c					Rated current A	rpm
HDA/02	143	138	240	111	11.2	265/460	60	2.25/1.3	3330	
HDA/03	143				13.0	1.32		4.85/2.8	3260	
HDA/04	164				13.4	1.32		4.85/2.8	3260	

* The performance curves are based on $1 \text{ mm}^2/\text{s}$ (cSt) kinematic viscosity values and 997 kg/m^3 density
 ** Curve tolerance according to ISO 9906:2012 Grade 3B.
 *** HDA/04, HDA/05 and HDA/06 pumps have IE2 motors. According to IEC 60034-30-1:2014 standard these pumps are excluded from efficiency class since their motors are completely integrated into the pump.

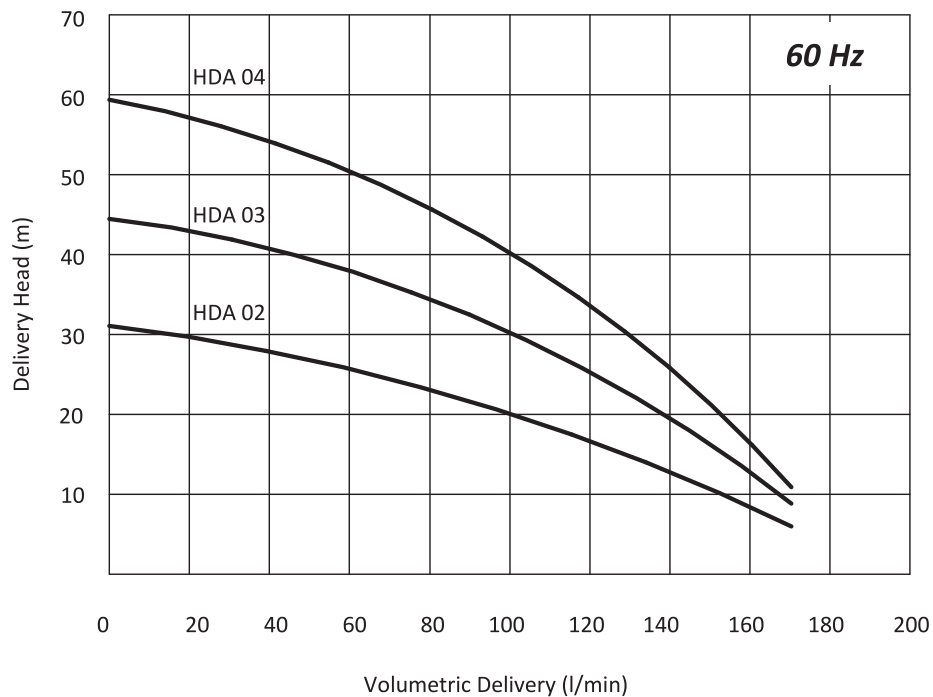
Performance Curve



HDB PUMP

Applications:

- Cutting, turning, milling, boring, grinding and similar applications of the machine tools,
- Especially used for deep hole boring operations due to supply 25 bar pressure,
- Circulation systems. HDB Pumps are used for pumping of cutting / cooling fluids.

Fluid Specifications:

- Coolants,
- Cutting oils,
- Grinding oils,
- Water,
- Fluid temperature 0...80 °C
- Kinematic viscosity 1...30 mm²/s

Materials:

Pump body	: Cast iron - DIN GG 25
Bottom plate	: Sheet iron
Diffuser	: Stainless steel - DIN 4301 (AISI 304)
Impeller	: Stainless steel - DIN 4301 (AISI 304)
Strainer	: Stainless steel - DIN 4301 (AISI 304)
Pump shaft	: Stainless steel - DIN 4401 (AISI 316)
O-ring	: Viton
Mechanical seal	: C - SiC - Viton TC - TC - Viton (Optional)
Electric motor	: 3 phase induction motor IE3 - 2 pole, Protection degree IP 55

* M16x1,5 cable gland is used on HDB/06 pump.

** The performance curves are based on 1 mm²/s (cSt) kinematic viscosity values and 997 kg/m³ density

*** Curve tolerance according to ISO 9906:2012 Grade 3B.

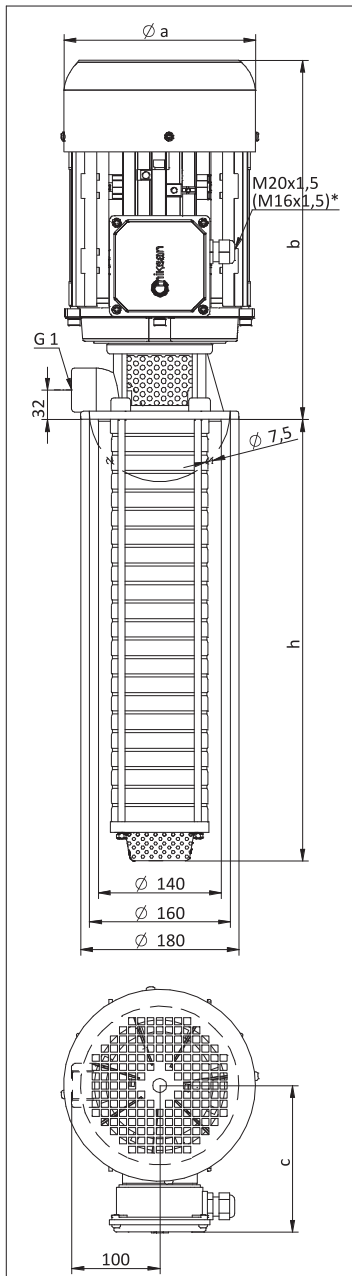
DIMENSIONS & NOMINAL VALUES

TYPE	Depth of immersion h (mm)	a b c			Weight kg	Power kW	Voltage V(Δ/Y)	Frequency Hz	Rated current A	Speed rpm
		mm								
HDB/06	206	176	340	139	24.5	2.65	265/460	60 Hz	7.79/4.5	3490
HDB/08	248	176	340	139	25.0	2.65			7.79/4.5	3490
HDB/10	291	194	397	150	31.5	3.6			10.4/6.0	3495
HDB/12	333	194	397	150	35.5	4.8			13.5/7.8	3485
HDB/15	396	194	397	150	36.0	4.8			13.5/7.8	3485
HDB/17	438	218	410	163	42.0	6.6			18.4/10.6	3520

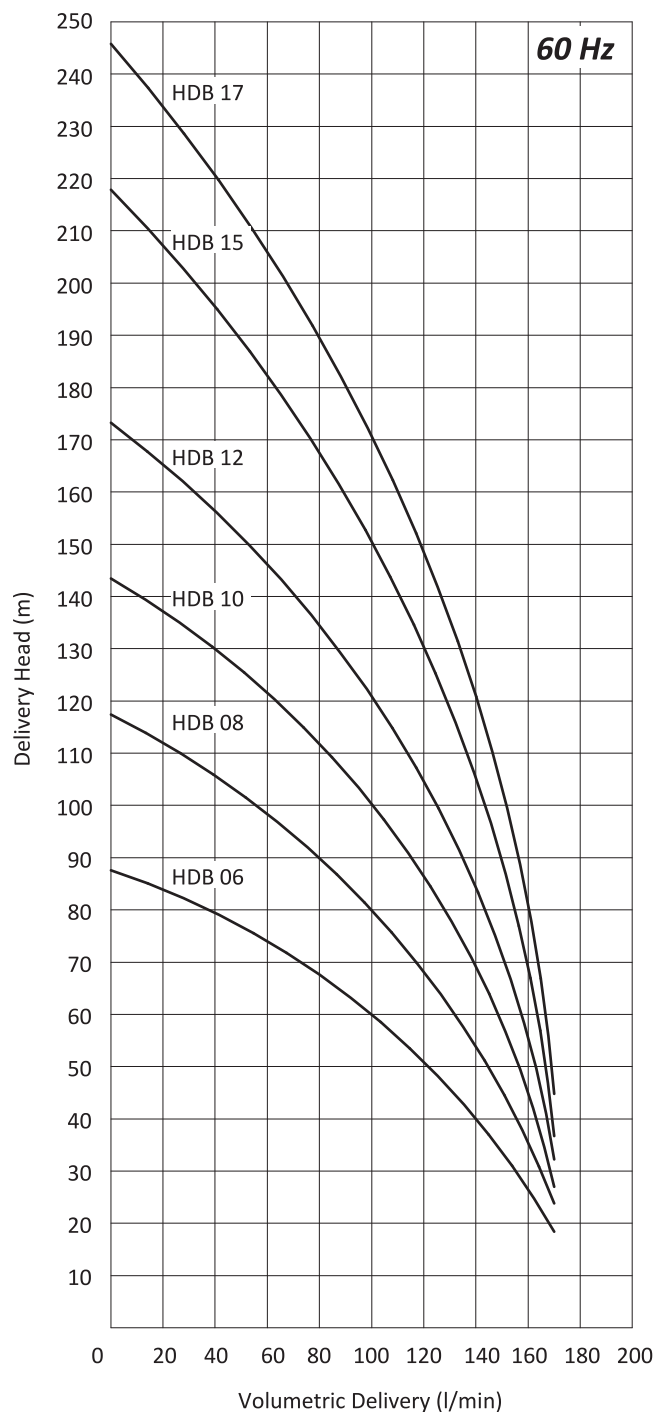
Performance Curve



HEB PUMP

Applications:

- Cutting, turning, milling, boring, grinding and similar applications of the machine tools,
- Especially used for deep hole boring operations due to supply 23,5 bar pressure,
- Circulation systems. HEB Pumps are used for pumping of cutting / cooling fluids.

Fluid Specifications:

- Coolants,
- Cutting oils,
- Grinding oils,
- Water,
- Fluid temperature 0...80 °C
- Kinematic viscosity 1...30 mm²/s

Materials:

Pump body	: Cast iron - DIN GG 25
Bottom plate	: Cast iron - DIN GG 25
Diffuser	: Stainless steel - DIN 4301 (AISI 304)
Impeller	: Stainless steel - DIN 4301 (AISI 304)
Strainer	: Stainless steel - DIN 4301 (AISI 304)
Pump shaft	: Stainless steel - DIN 4401 (AISI 316)
O-ring	: Viton
Mechanical seal	: C - SiC - Viton TC - TC - Viton (Optional)
Electric motor	: 3 phase induction motor IE3 - 2 pole, Protection degree IP 55

- * M16x1,5 cable gland is used on HEB 02 pump.
- ** M25x1,5 cable gland is used on HEB 14 to HEB 20 pumps.
- *** The performance curves are based on 1 mm²/s (cSt) kinematic viscosity values and 997 kg/m³ density
- **** Curve tolerance according to ISO 9906:2012 GRADE 3B.

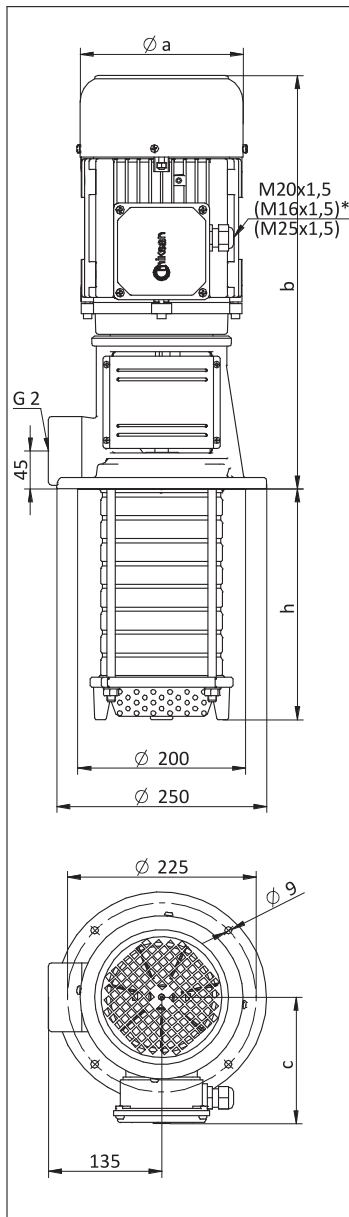
DIMENSIONS & NOMINAL VALUES

TYPE	Depth of immersion h (mm)	mm			Weight kg	Power kW	Voltage V(Δ/Y)	Frequency Hz	Rated current A	Speed rpm
		a	b	c						
HEB 02	167	176	437	139	28.0	1.8	265/460	60 Hz	5.72/3.3	3490
HEB 03	167	176	462	139	31.5	2.65			7.79/4.5	3490
HEB 04	194	194	489	150	38.0	3.6			10.4/6.0	3495
HEB 05	221	194	489	150	38.5	3.6	10.4/6.0	3495		
HEB 06	248	194	489	150	42.0	4.8	13.5/7.8	3485		
HEB 07	275	218	502	163	48.5	6.6	18.4/10.6	3520		
HEB 08	302	218	502	163	49.0	6.6	18.4/10.6	3520		
HEB 10	356	258	589	177	74.0	9.0	460 Δ	14.0	3505	
HEB 12	410	258	589	177	74.5	9.0		14.0	3505	
HEB 14	464	258	618	177	85.0	13.2		19.7	3510	

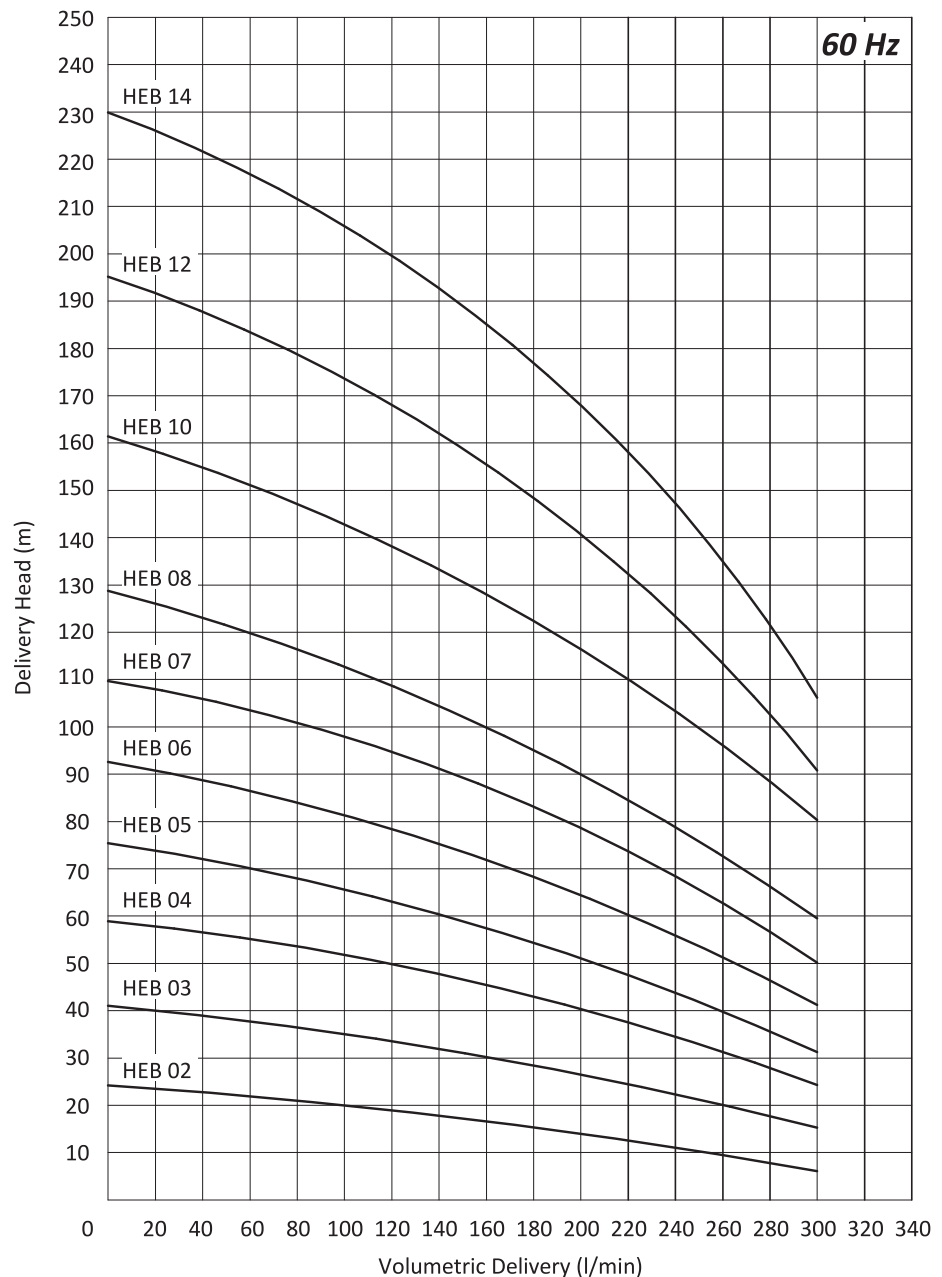
Performance Curve



HCD PUMP

Applications:

- Cutting, turning, milling, boring, grinding and similar applications of the machine tools,
- Especially used for deep hole boring operations due to supply 25 bar pressure,
- Circulation systems. HCD Pumps are used for pumping of cutting / cooling fluids.

Fluid Specifications:

- Coolants,
- Cutting oils,
- Grinding oils,
- Water,
- Fluid temperature 0...80 °C
- Kinematic viscosity 1...30 mm²/s

Materials:

Pump body	: Cast iron - DIN GG 25
Cover	: Cast iron - DIN GG 25
Diffuser	: Stainless steel - DIN 4301 (AISI 304)
Impeller	: Stainless steel - DIN 4301 (AISI 304)
Strainer	: Stainless steel - DIN 4301 (AISI 304)
Pump shaft	: Stainless steel - DIN 4401 (AISI 316)
O-ring	: Viton
Mechanical seal	: C - SiC - Viton TC - TC - Viton (Optional)
Electric motor	: 3 phase induction motor IE3 - 2 pole, Protection degree IP 55

* M16x1,5 cable gland is used on HCD/08 pump.

** The performance curves are based on 1 mm²/s (cSt) kinematic viscosity values and 997 kg/m³ density

*** Curve tolerance according to ISO 9906:2012 Grade 3B.

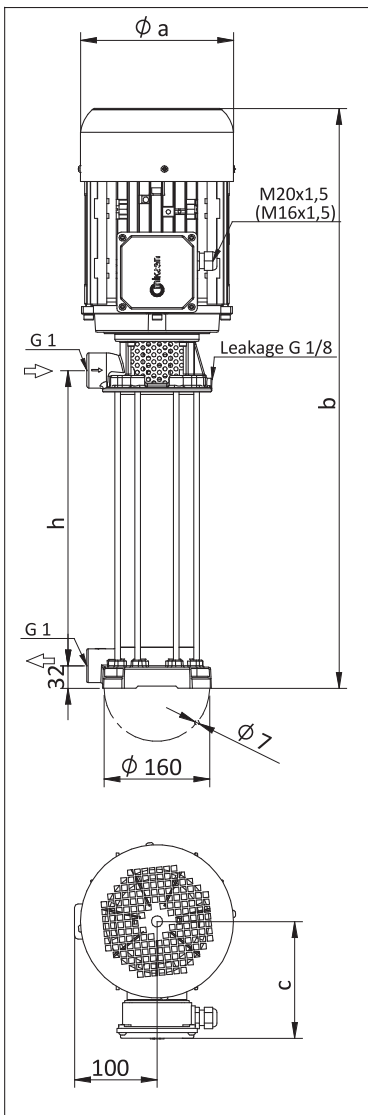
DIMENSIONS & NOMINAL VALUES

TYPE	Length			Weight kg	Power kW	Voltage V(Δ/Y)	Frequency Hz	Rated current A	Speed rpm	
	h (mm)	a	b							c
HCD/08	316	157	655	118	27.0	1.8	265/460	60	5.72/3.3	3490
HCD/10	316	176	680	139	30.5	2.65			7.79/4.5	3490
HCD/12	420	176	816	139	37.0	3.6			10.4/6.0	3495
HCD/15	420	194	816	150	38.0	3.6			10.4/6.0	3495
HCD/17	524	194	920	150	41.0	4.8			13.5/7.8	3485

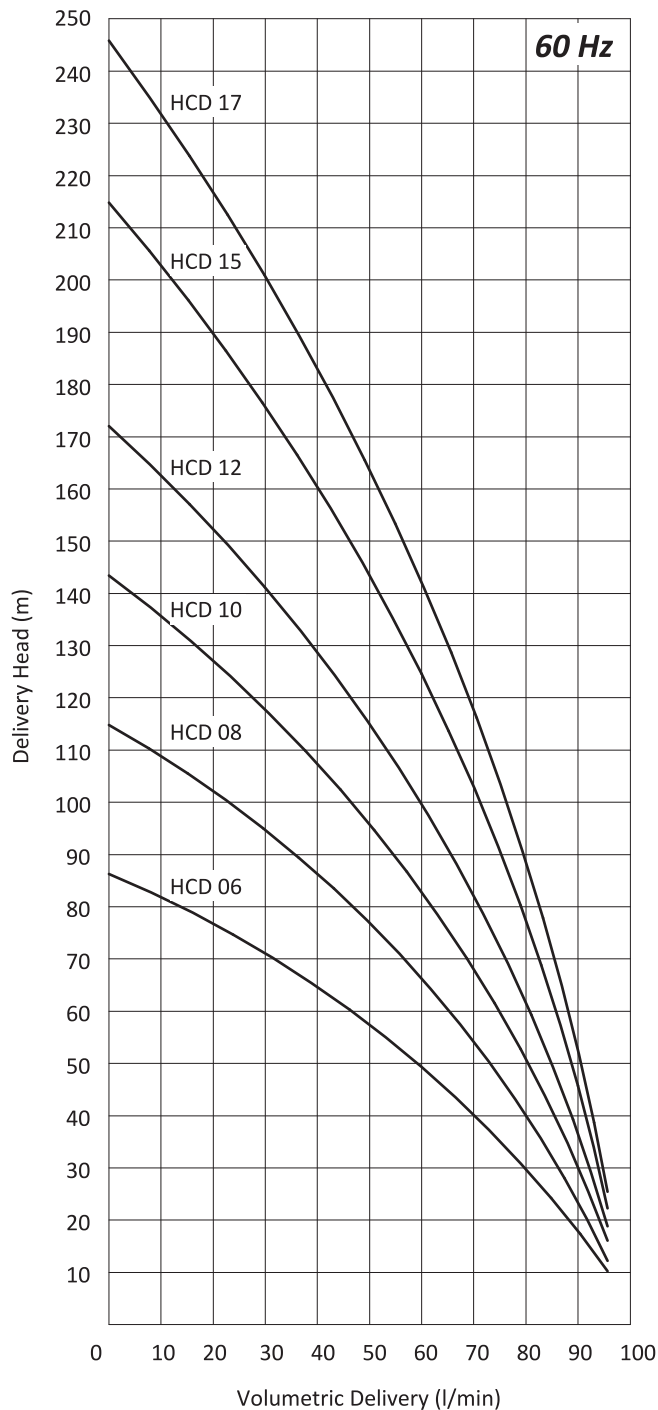
Performance Curve



HDD PUMP

Applications:

- Cutting, turning, milling, boring, grinding and similar applications of the machine tools,
- Especially used for deep hole boring operations due to supply 25 bar pressure,
- Circulation systems. HDD Pumps are used for pumping of cutting / cooling fluids.

Fluid Specifications:

- Coolants,
- Cutting oils,
- Grinding oils,
- Water,
- Fluid temperature 0...80 °C
- Kinematic viscosity 1...30 mm²/s

Materials:

Pump body	: Cast iron - DIN GG 25
Cover	: Cast iron - DIN GG 25
Diffuser	: Stainless steel - DIN 4301 (AISI 304)
Impeller	: Stainless steel - DIN 4301 (AISI 304)
Strainer	: Stainless steel - DIN 4301 (AISI 304)
Pump shaft	: Stainless steel - DIN 4401 (AISI 316)
O-ring	: Viton
Mechanical seal	: C - SiC - Viton TC - TC - Viton (Optional)
Electric motor	: 3 phase induction motor IE3 - 2 pole, Protection degree IP 55

* M16x1,5 cable gland is used on HDD/08 pump.

** The performance curves are based on 1 mm²/s (cSt) kinematic viscosity values and 997 kg/m³ density

*** Curve tolerance according to ISO 9906:2012 Grade 3B.

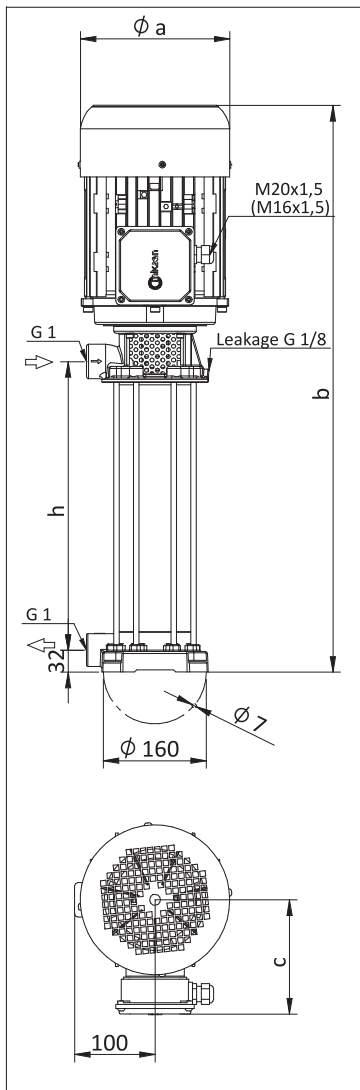
DIMENSIONS & NOMINAL VALUES

TYPE	Length			Weight kg	Power kW	Voltage V(Δ/Y)	Frequency Hz	Rated current A	Speed rpm
	h (mm)	a	b						
HDD/08	316	176	680	139	30.0	265/460	60 Hz	7.79/4.5	3490
HDD/10	316	194	712	150	36.5	3.6		10.4/6.0	3495
HDD/12	420	194	816	150	41.0	4.8		13.5/7.8	3485
HDD/15	420	194	816	150	41.5	4.8		13.5/7.8	3485
HDD/17	524	218	933	163	47.0	6.6		18.4/10.6	3520

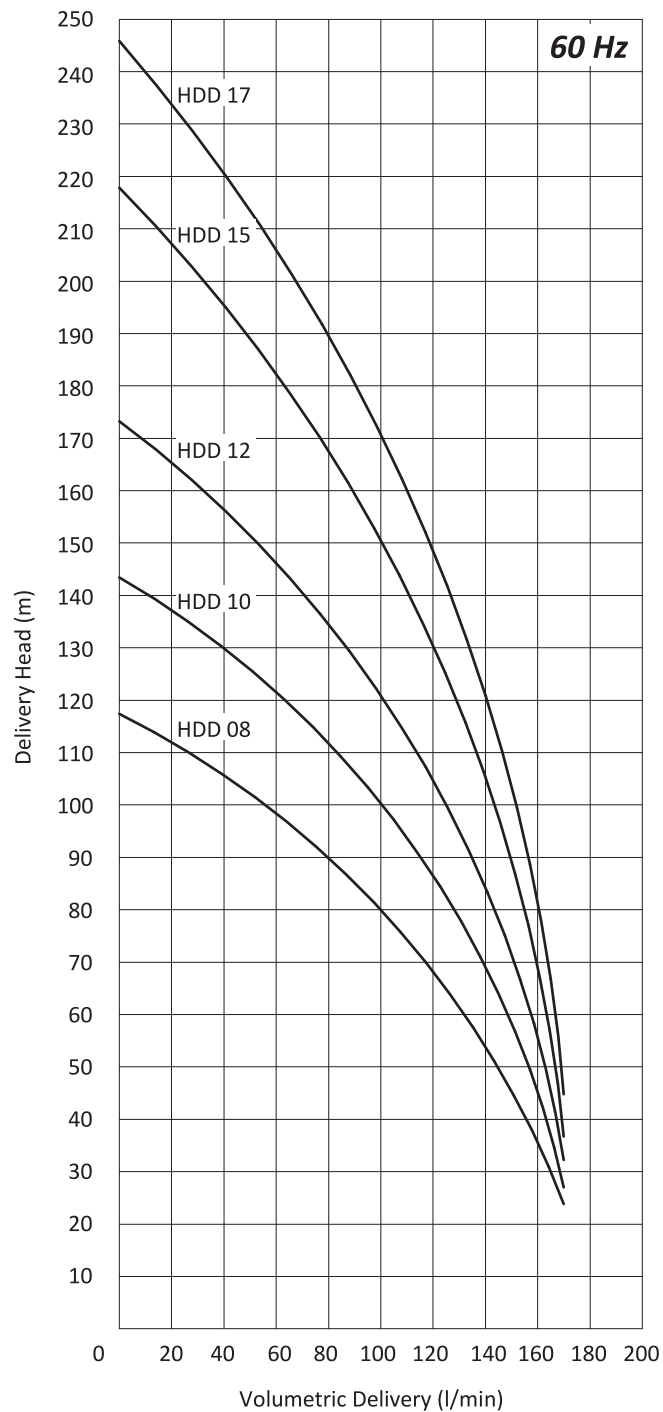
Performance Curve



HED PUMP

Applications:

- Cutting, turning, milling, boring, grinding and similar applications of the machine tools,
- Especially used for deep hole boring operations due to supply 23,5 bar pressure,
- Circulation systems. HED Pumps are used for pumping of cutting / cooling fluids.

Fluid Specifications:

- Coolants,
- Cutting oils,
- Grinding oils,
- Water,
- Fluid temperature 0...80 °C
- Kinematic viscosity 1...30 mm²/s

Materials:

Pump body	: Cast iron - DIN GG 25
Cover	: Cast iron - DIN GG 25
Diffuser	: Stainless steel - DIN 4301 (AISI 304)
Impeller	: Stainless steel - DIN 4301 (AISI 304)
Strainer	: Stainless steel - DIN 4301 (AISI 304)
Pump shaft	: Stainless steel - DIN 4401 (AISI 316)
O-ring	: Viton
Mechanical seal	: C - SiC - Viton TC - TC - Viton (Optional)
Electric motor	: 3 phase induction motor IE3 - 2 pole, Protection degree IP 55

* M16x1,5 cable gland is used on HED 02 and HED 03 pumps.

** M25x1,5 cable gland is used on HED 16, HED 18 and HED 20 pumps.

*** The performance curves are based on 1 mm²/s (cSt) kinematic viscosity values and 997 kg/m³ density

**** Curve tolerance according to ISO 9906:2012 Grade 3B.

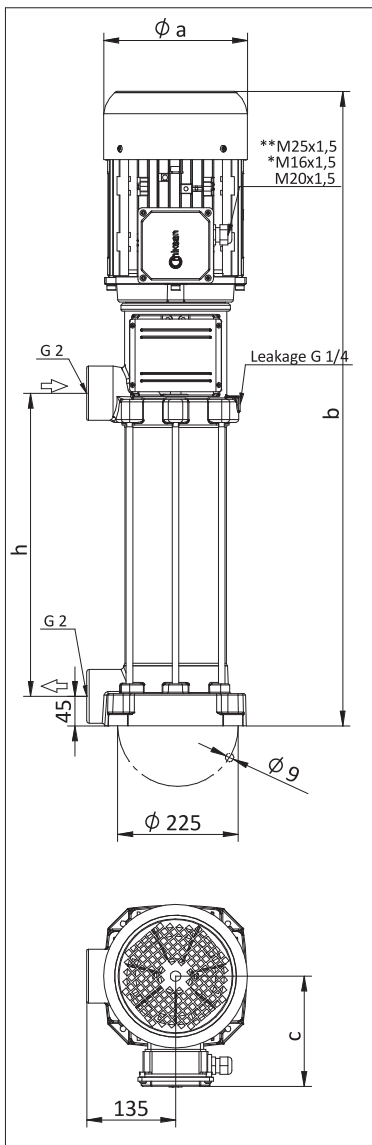
DIMENSIONS & NOMINAL VALUES

TYPE	Length			Weight kg	Power kW	Voltage V(Δ/Y)	Frequency Hz	Rated current A	Speed rpm	
	h (mm)	a	b							c
HED 02	269	176	705	139	38.0	265/460	60 Hz	5.72/3.3	3490	
HED 03	269	176	730	139	41.5			7.79/4.5	3490	
HED 04	269	194	762	150	48.0			10.4/6.0	3495	
HED 05	269	194	762	150	48.5			10.4/6.0	3495	
HED 06	350	194	843	150	52.0			13.5/7.8	3485	
HED 07	350	218	856	163	58.5			6.6	18.4/10.6	3520
HED 08	350	218	856	163	59.0			6.6	18.4/10.6	3520
HED 10	460	258	1021	177	84.0	460 Δ	14.0	3505		
HED 12	460	258	1021	177	84.5		9.0	14.0	3505	
HED 14	568	258	1159	177	95.0		13.2	19.7	3510	

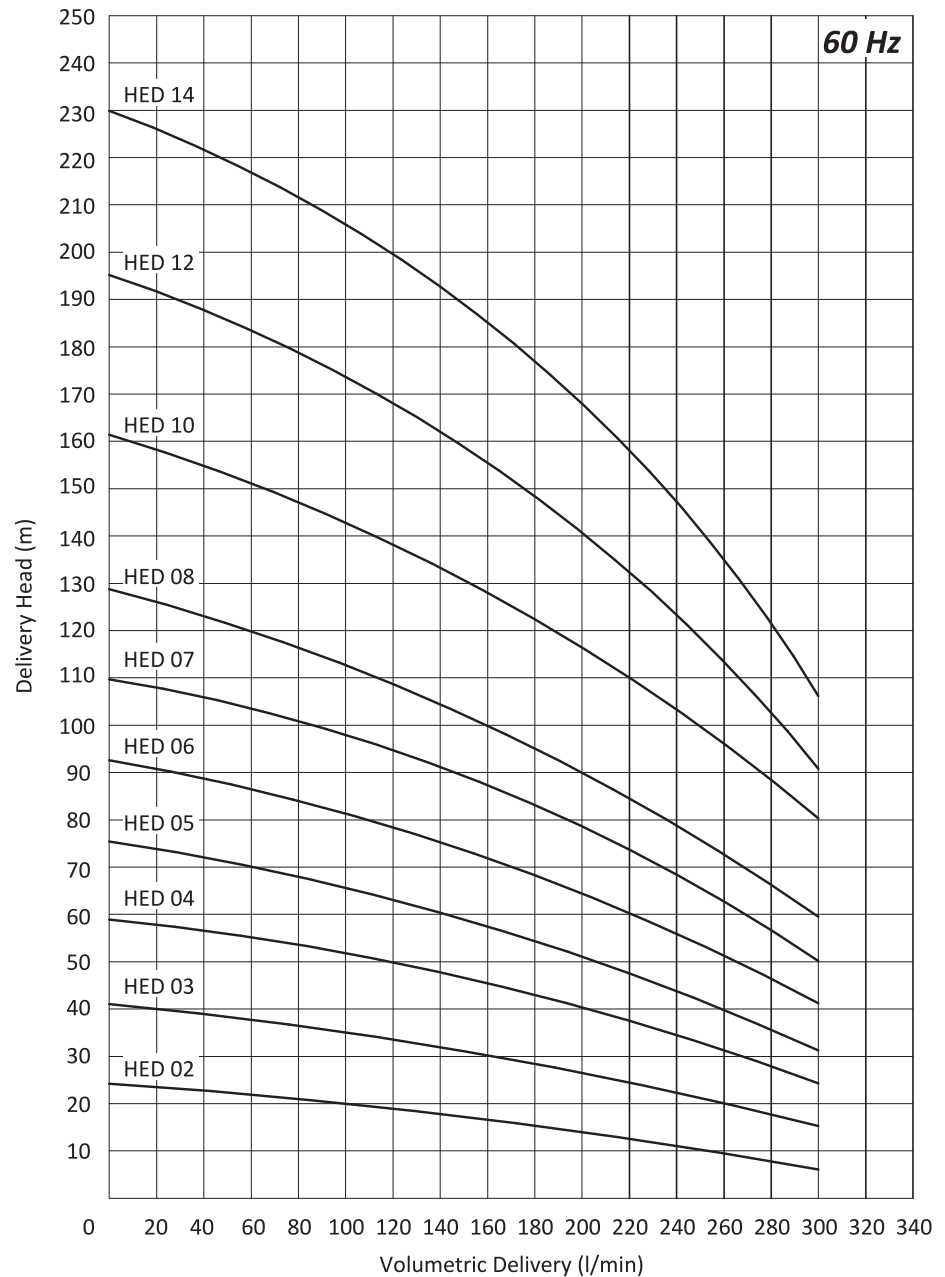
Performance Curve



FP40 PUMP

Applications:

- Cutting, turning, milling, boring, grinding and similar applications of the machine tools,
- Cooling systems,
- Circulation systems. FP40 Pumps are used for pumping of cutting / cooling fluids.
- Pump has a peripheral impeller so it is recommended to use filtered fluid applications.

Fluid Specifications:

- Coolants,
- Cutting oils,
- Fluid temperature 0...80 °C
- Kinematic viscosity 1...90 mm²/s

Materials:

Pump body	: Cast iron - DIN GG 25
Volute	: Cast iron - DIN GG 25
Impeller	: Brass
Pump shaft	: Engineering steel - AISI 1040 (DIN C35) Stainless steel- AISI 420(DIN X20Cr13) (Optional)
Electric motor	: 3 phase induction motor - 2 pole, Protection degree IP 55

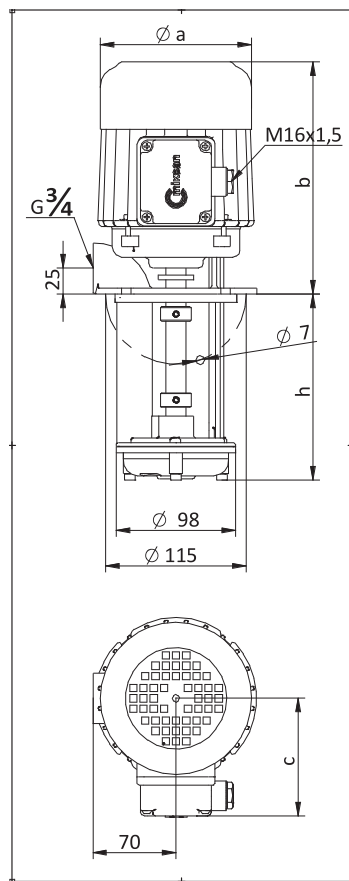

DIMENSIONS & NOMINAL VALUES

TYPE	Depth of immersion h (mm)	mm			Weight kg	Power kW	Voltage V(Δ/Y)	Frequency Hz	Rated current A	Speed rpm
		a	b	c						
FP 40/15	150	123	190	95	7.8	0.40	230/400	50	2.43/1.4	2730
FP 40/20	200				8.0					
FP 40/25	250				8.5					
FP 40/30	300				8.6					
FP 42/13	130	138	240	111	11.4	1.1	230/400	50	4.85/2.8	2720
FP 42/17	170				11.6					
FP 42/22	220				11.8					
FP 42/27	270				12.0					
FP 43/15	155	176	330	139	20.5	1.5	230/400	50	5.72/3.3	2910
FP 43/19	195				20.7					
FP 43/24	245				20.9					
FP 43/29	295				21.1					

* M20x1,5 cable gland is used on FP 43 pumps.

** Pump dimensions according to EN 12157.

*** The performance curves are based on 1 mm²/s (cSt) kinematic viscosity values and 997 kg/m³ density

**** Curve tolerance according to ISO 9906:2012 Grade 3B.

***** FP 42 pump has IE2 motor. According to IEC 60034-30-1:2014 standard this pump is excluded from efficiency class since its motor is completely integrated into the pump.

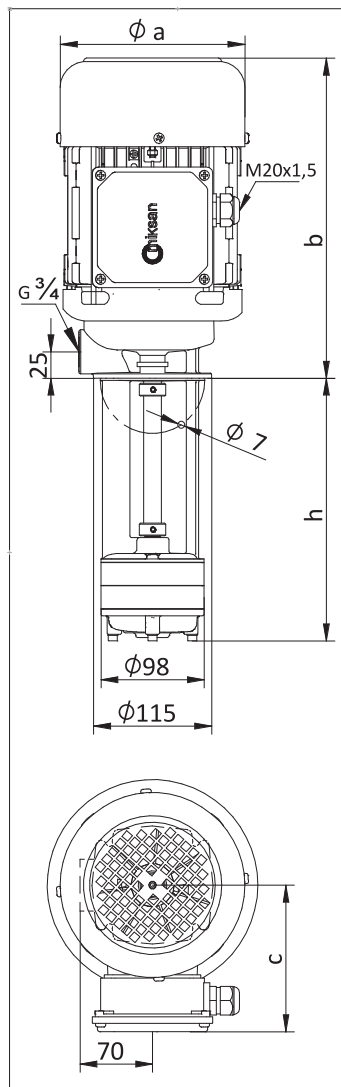

Performance Curve

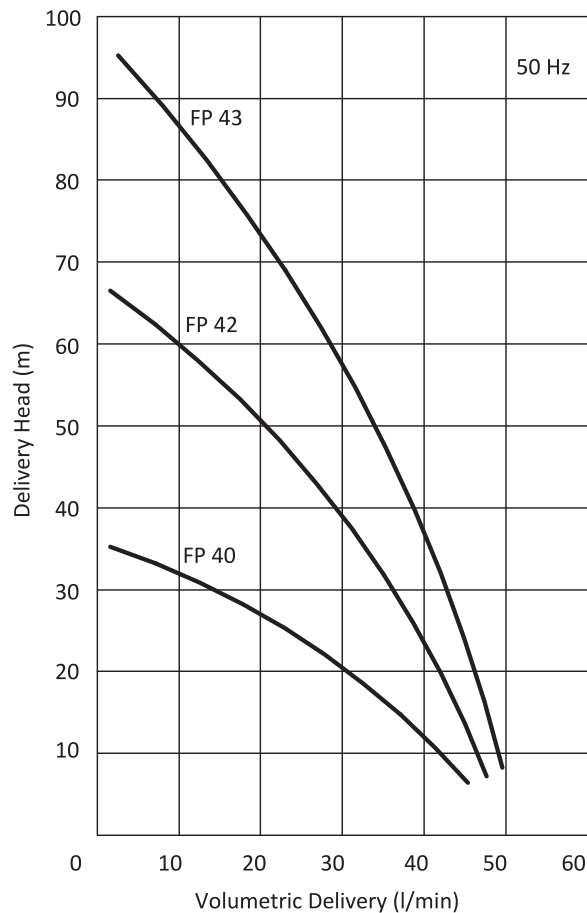



FP90 PUMP

Applications:

- Cutting, turning, milling, boring, grinding and similar applications of the machine tools,
- Cooling systems,
- Circulation systems. FP90 Pumps are used for pumping of cutting / cooling fluids.
- Pump has a peripheral impeller so it is recommended to use filtered fluid applications.

Fluid Specifications:

- Coolants,
- Cutting oils,
- Fluid temperature 0...80 °C
- Kinematic viscosity 1...90 mm²/s

Materials:

Pump body	: Cast iron - DIN GG 25
Volute	: Cast iron - DIN GG 25
Impeller	: Brass
Pump shaft	: Engineering steel - AISI 1040 (DIN C35) Stainless steel- AISI 420(DIN X20Cr13) (Optional)
Electric motor	: 3 phase induction motor - 2 pole, Protection degree IP 55

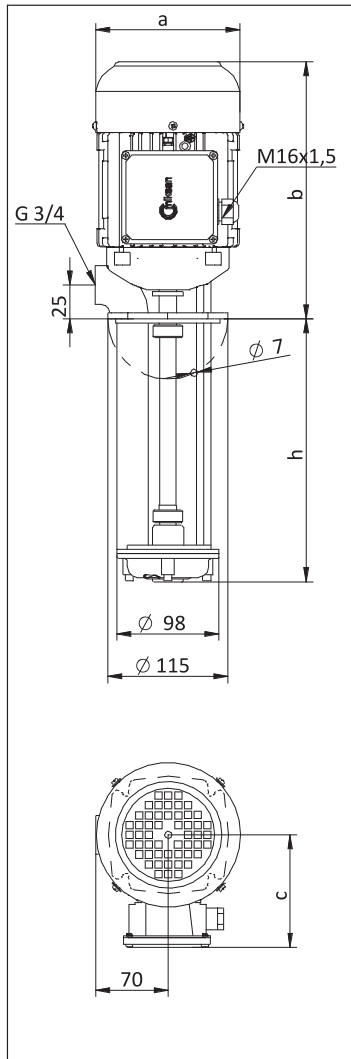

DIMENSIONS & NOMINAL VALUES

TYPE	Depth of immersion h (mm)	mm			Weight kg	Power kW	Voltage V(Δ/Y)	Frequency Hz	Rated current A	Speed rpm
		a	b	c						
FP 90/11	110	138	240	111	10.6	1.1	230/400	50	4.85/2.8	2720
FP 90/15	150				10.9					
FP 90/20	200				11.2					
FP 90/25	250				11.5					
FP 90/30	300				11.8					

- * Pump dimensions according to EN 12157.
- ** The performance curves are based on 1 mm²/s (cSt) kinematic viscosity values and 997 kg/m³ density
- *** Curve tolerance according to ISO 9906:2012 Grade 3B.
- **** FP 90 pump has IE2 motor. According to IEC 60034-30-1:2014 standard this pump is excluded from efficiency class since its motor is completely integrated into the pump.

Performance Curve

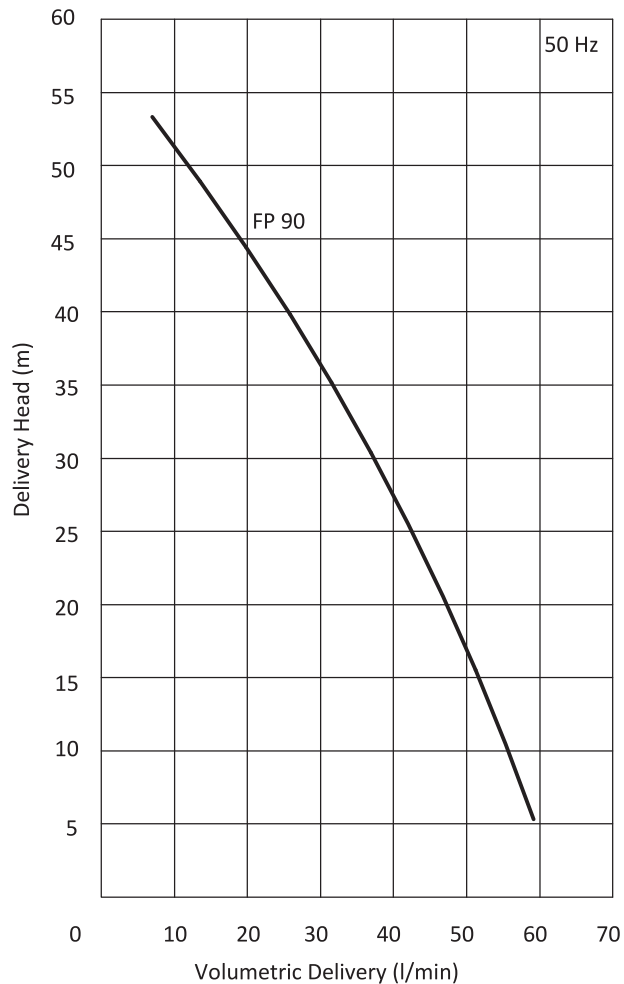

KEP SERIES SELF-PRIMING PUMPS

KEP series self-priming pumps are centrifugal pumps with open impeller mounted directly to the motor shaft and used for pumping liquids including high air occlusion and chips in machine tools industry.

Application Fields;

- Fluids with high air occlusion,
- Contaminated liquids,
- Liquids containing solid particles,
- Alkaline, solvents, coolants and lubricants etc.
- Surface washing, cleaning, degreasing,
- Recycling and filtration in Machine-tool industry,
- Circulation of coolant,

Fluids;

- Water,
- Emulsions,
- Cutting oils,

Specifications;

- Self-priming after the pump casing has been filled with the fluid.
- No back flow valve required.
- Insensitive to the penetration of gas and air.
- Chip size max. 9 mm,
- Easy to clean out via drain plug.
- Small space requirements due to the compact design.
- All pumps include single mechanical seal.

Materials;

Pump Body	- GG 25
Motor Flange	- GG 25
Impeller	- GG 25
Pump Shaft	- AISI 420
Mechanical Seal	- C-SiC-Viton
	- TC-TC-Viton (optional)

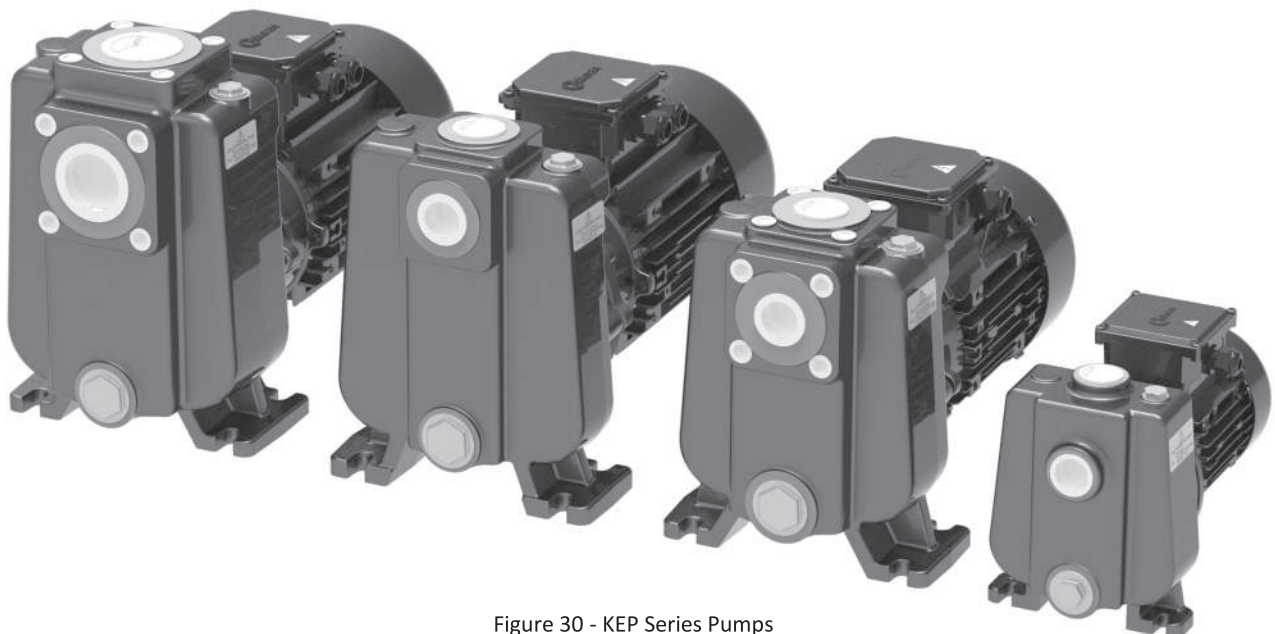
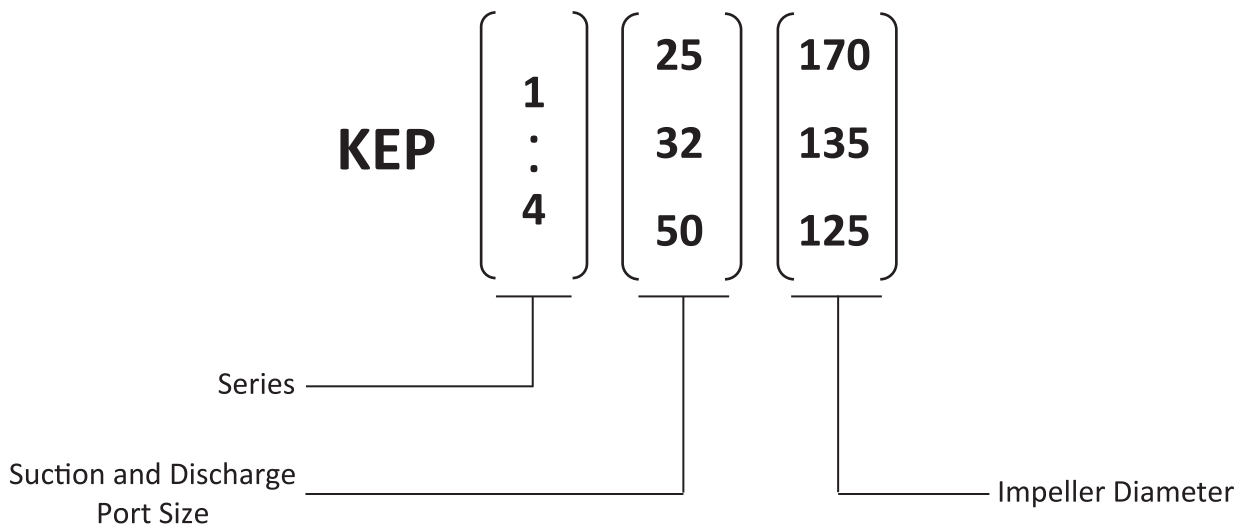

Figure 30 - KEP Series Pumps

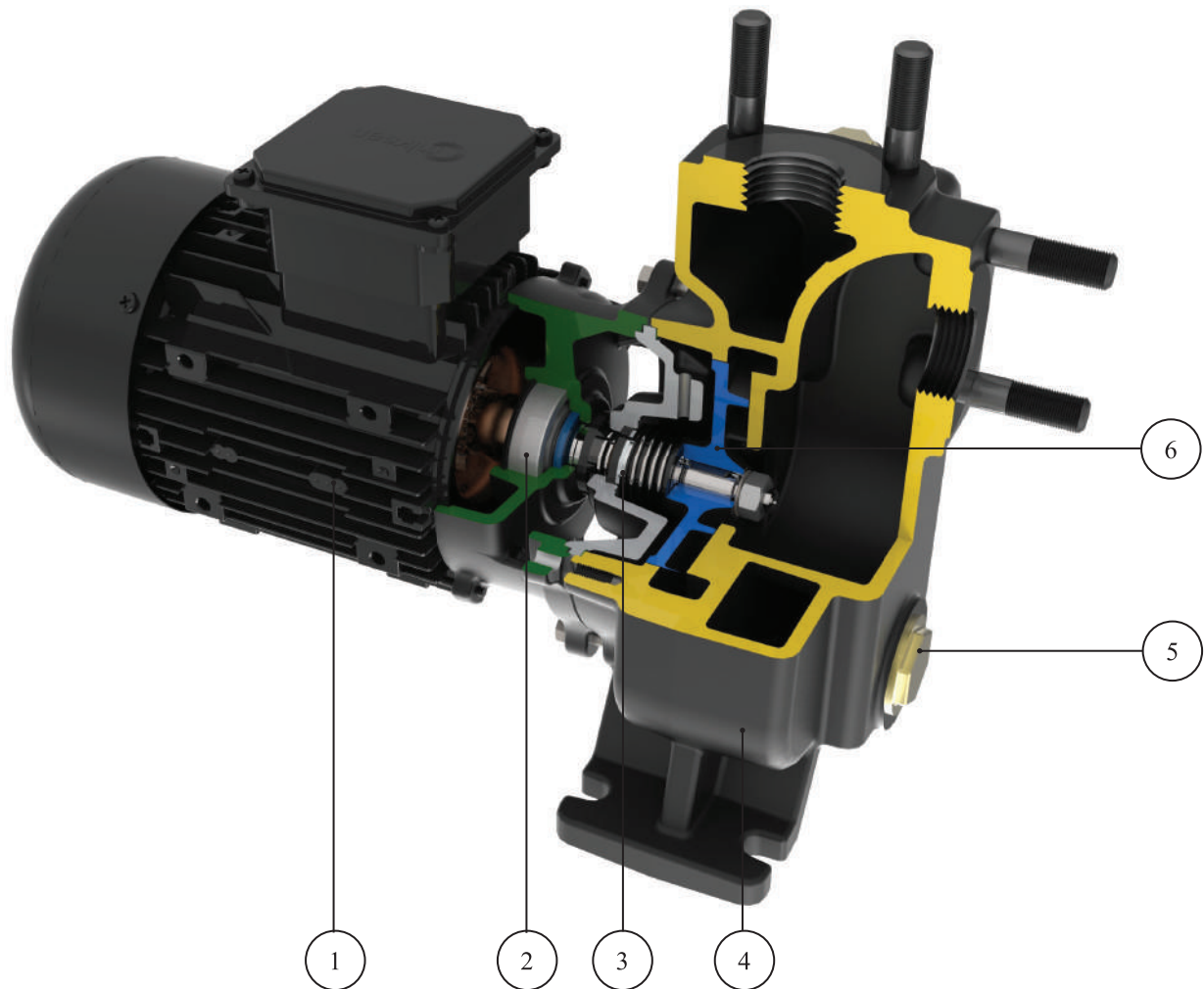

Figure 31 - KEP Series Pumps Section View

1. Electric Motor

Special shaft and flange mounted electric motors are used on KEP series. Motor shaft is directly mounted to impeller.

Power of 3 phase electric motors are 4,0 kW and 3,0 kW in frame size of 100; 2,2 kW and 1,5 kW in frame size of 90; 1,1 kW in the frame size of 80; 0,37 kW and 0,25 kW in frame size of 63.

2. Bearings

Motor flange is made of cast iron and the front bearing is bigger than standard electric motors so it offers increased strength against to axial forces.

3. Mechanical Seal

Standard mechanical seal material is C-SiC-Viton. TC-TC-Viton mechanical seal is available upon request.

4. Pump Body

Self-priming after the pump body is filled with the fluid once.

5. Drain Plug

KEP pumps can be easily clean out via drain plug without dismantling the pump from the system.

6. Impeller

Special impeller design that allows self-priming without foot valve requirement.



KEP 125 PUMP

Applications:

- Cutting, turning, milling, boring, grinding and similar applications of the machine tools,
- Filtration systems,
- Circulation systems.
- KEP Pumps are used for pumping of cutting / cooling fluids.

Fluid Specifications:

- Coolants,
- Cutting oils,
- Grinding oils,
- Water
- Chip containing liquids (max. 6 mm)
- Fluid temperature 0...60 °C
- Kinematic viscosity 1...30 mm²/s

Materials:

Pump body	: Cast iron - DIN GG25
Motor Flange	: Cast iron - DIN GG25
Impeller	: Cast iron - DIN GG25
Shaft	: Stainless steel - AISI 420 (DIN 1.4021)
O-ring	: Viton
Mechanical Seal	: C-SiC-Viton
Electric motor	: 3 phase induction motor - 2 pole, 1 phase induction motor (Optional) Protection degree IP 54

Suction Head and Priming Time

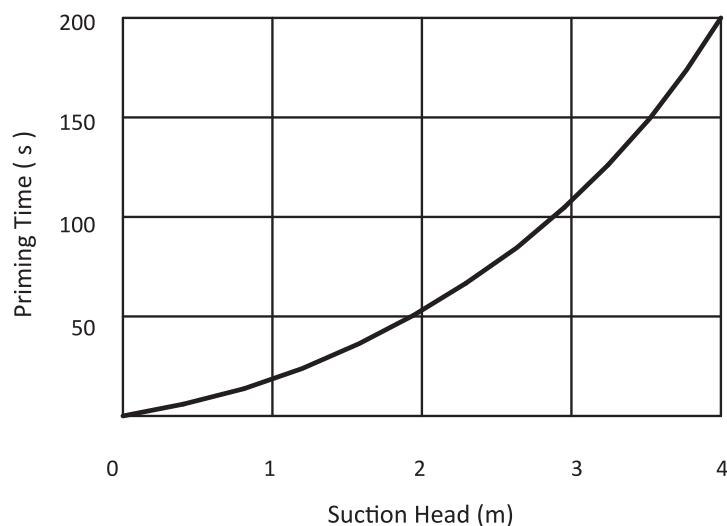

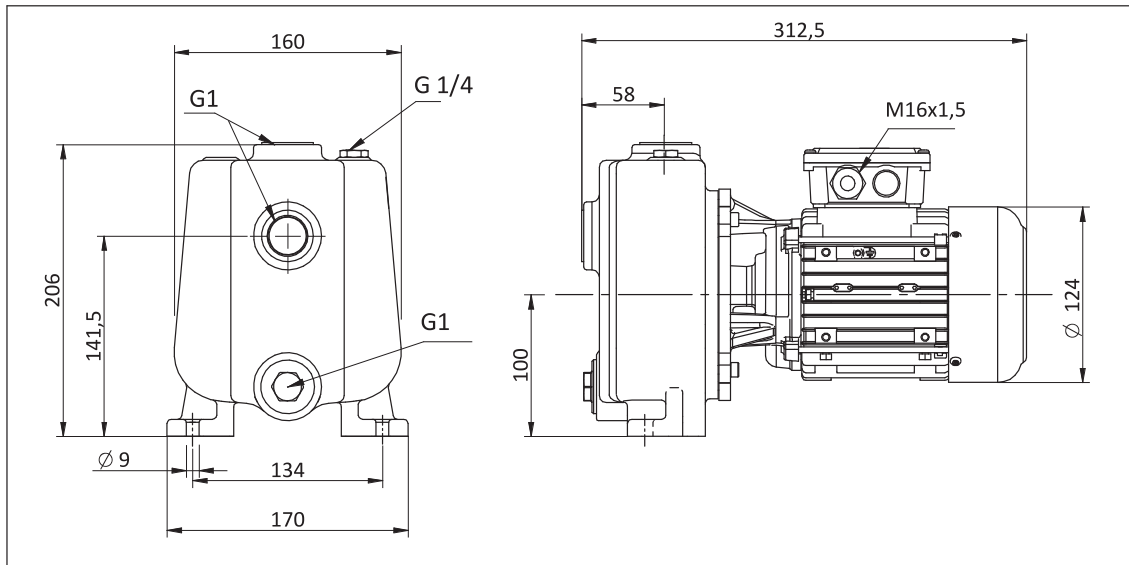

DIMENSIONS & NOMINAL VALUES

	Weight	Power	Voltage	Frequency	Rated current	Speed
TYPE	kg	kW	V(Δ/Y)	Hz	A	rpm
KEP 125/100	12.0	0.25	230/400	50	1.26/0.73	2760
KEP 125/150	12.5	0.37			2.16/1.25	2820

* The performance curves are based on 1 mm²/s (cSt) kinematic viscosity values and 997 kg/m³ density

** Curve tolerance according to ISO 9906:2012 Grade 3B.

Performance Curve



KEP 232 PUMP



Applications:

- Cutting, turning, milling, boring, grinding and similar applications of the machine tools,
- Filtration systems,
- Circulation systems.
- KEP Pumps are used for pumping of cutting / cooling fluids.

Fluid Specifications:

- Coolants,
- Cutting oils,
- Grinding oils,
- Water
- Chip containing liquids (max. 9 mm)
- Fluid temperature 0...60 °C
- Kinematic viscosity 1...30 mm²/s

Materials:

Pump body	: Cast iron - DIN GG25
Motor Flange	: Cast iron - DIN GG25
Impeller	: Cast iron - DIN GG25
Shaft	: Stainless steel - AISI 420 (DIN 1.4021)
Mechanical Seal	: C-SiC-Viton
Electric motor	: 3 phase induction motor - 2 pole, Optionally 4-pole, Protection degree IP 54

Suction Head and Priming Time

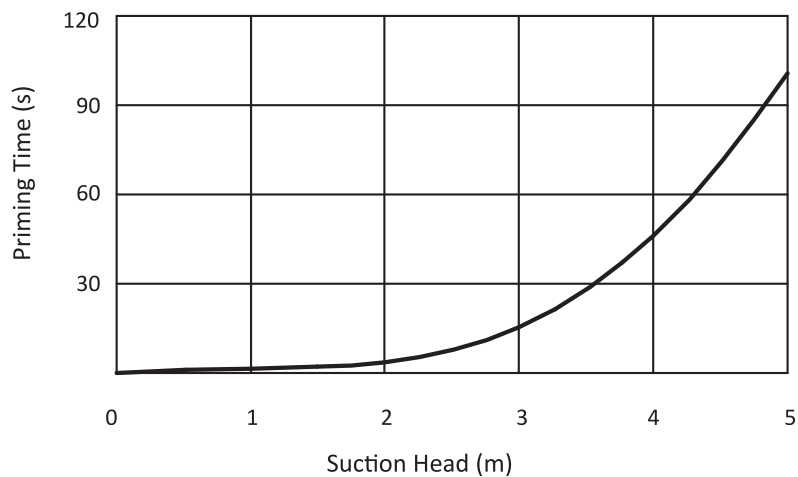

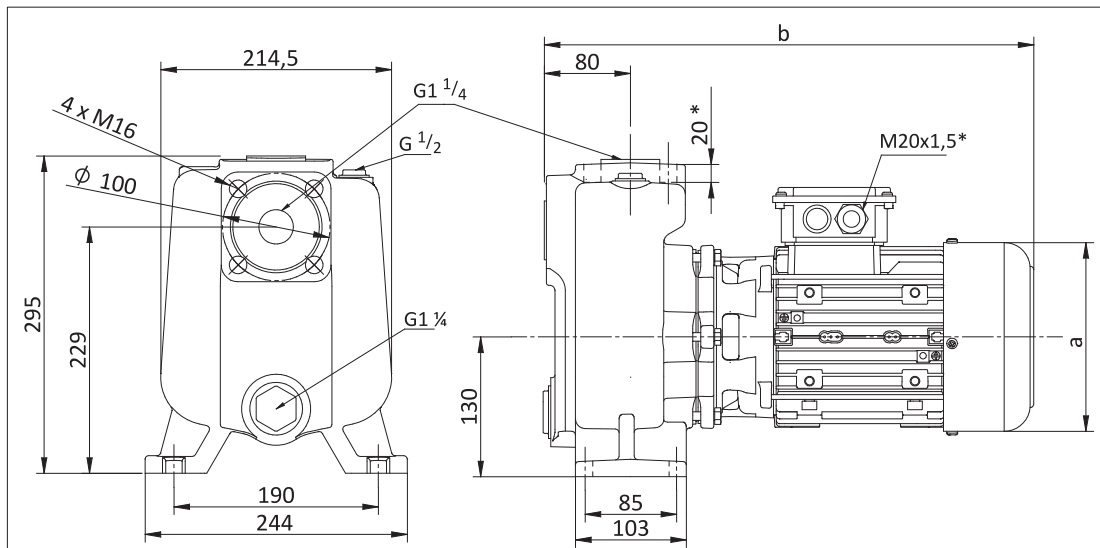

DIMENSIONS & NOMINAL VALUES

TYPE	mm		Weight kg	Power kW	Voltage V(Δ/Y)	Frequency Hz	Rated current A	Speed rpm
	a	b						
KEP 232/135-4	157	411	30.5	0.55	230/400	50	2.96/1.71	1410
KEP 232/110		430	31.5	1.1			4.16/2.4	2890
KEP 232/120	176	455	35.5	1.5			5.72/3.3	2910
KEP 232/128		485	38.0	2.2			7.79/4.5	2905
KEP 232/135	194	485	45.0	3.0			10.39/6.0	2905

- * Flange connection (DIN EN 1092-2 PN 16)
- ** The performance curves are based on 1 mm²/s (cSt) kinematic viscosity values and 997 kg/m³ density
- *** Curve tolerance according to ISO 9906:2012 Grade 3B.
- **** M16x1,5 cable gland is used on KEP 232/135-4 AND KEP 232/110 pumps.

Performance Curve

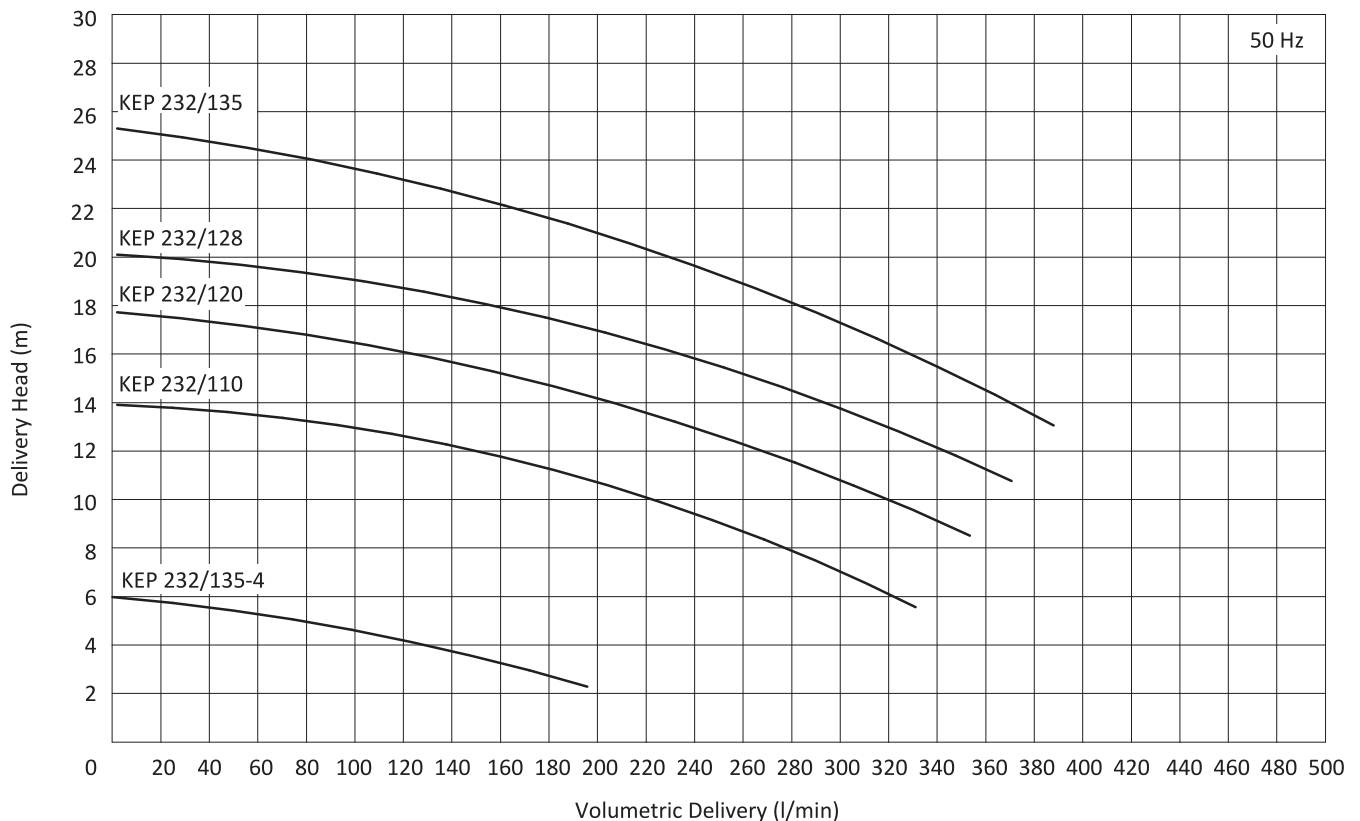

KEP 332 PUMP



Applications:

- Cutting, turning, milling, boring, grinding and similar applications of the machine tools,
- Filtration systems,
- Circulation systems.
- KEP Pumps are used for pumping of cutting / cooling fluids.

Fluid Specifications:

- Coolants,
- Cutting oils,
- Grinding oils,
- Water
- Chip containing liquids (max. 5 mm)
- Fluid temperature 0...60 °C
- Kinematic viscosity 1...30 mm²/s

Materials:

Pump body	: Cast iron - DIN GG25
Motor Flange	: Cast iron - DIN GG25
Impeller	: Cast iron - DIN GG25
Shaft	: Stainless steel - AISI 420 (DIN 1.4021)
Mechanical Seal	: C-SiC-Viton
Electric motor	: 3 phase induction motor - 2 pole, Protection degree IP 54

Suction Head and Priming Time

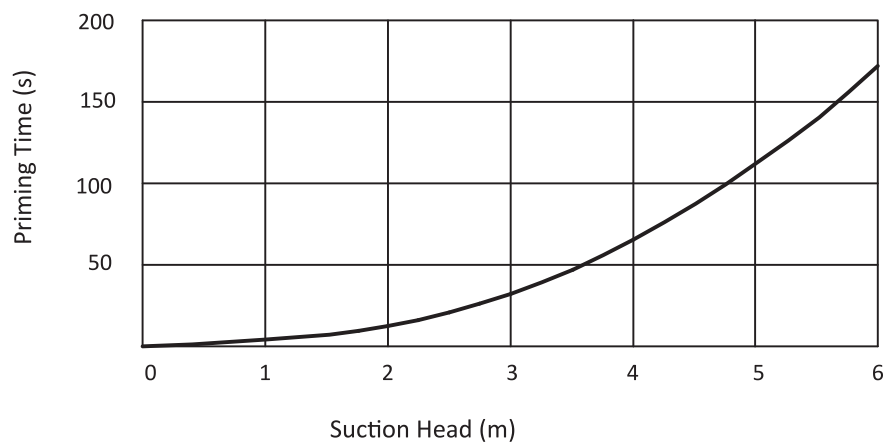

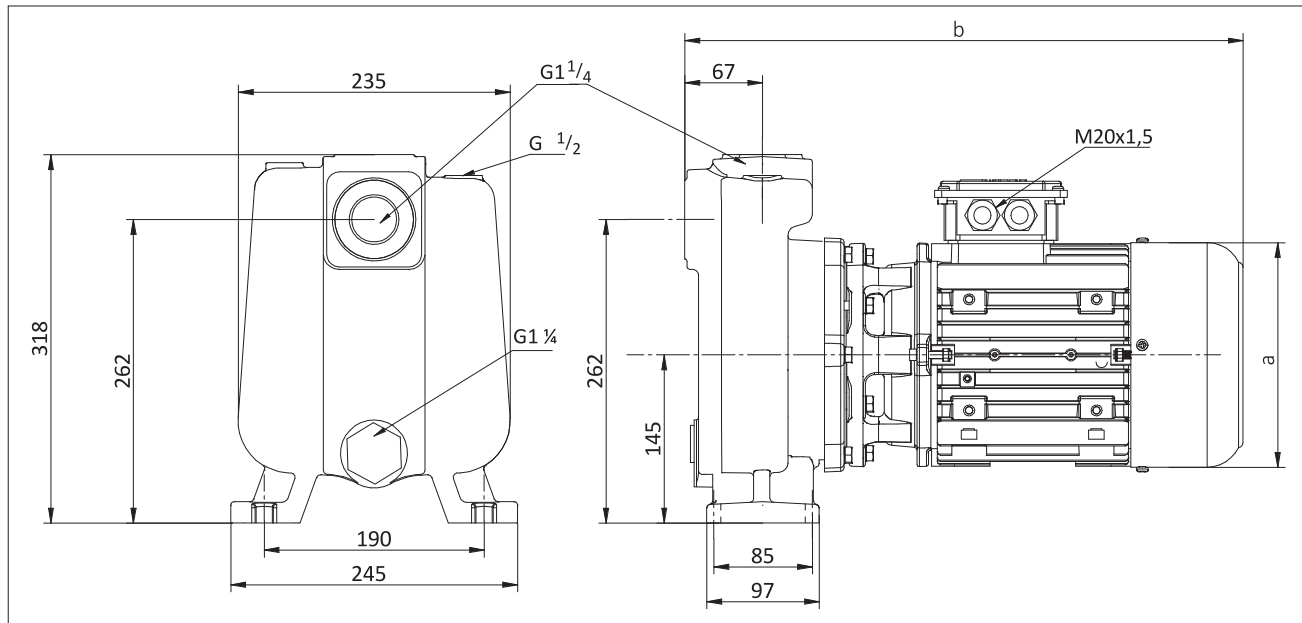

DIMENSIONS & NOMINAL VALUES

TYPE	mm		Weight	Power	Voltage	Frequency	Rated current	Speed
	a	b	kg	kW	V(ΔY)	Hz	A	rpm
KEP 332/136	176	425	34	1.5	230/400	50	5.72/3.3	2910
KEP 332/150		445	37	2.2			7.79/4.5	2905
KEP 332/160	194	478	43	3.0	4.0		10.39/6.0	2905
KEP 332/170			45	4.0			13.68/7.9	2900

* The performance curves are based on 1 mm²/s (cSt) kinematic viscosity values and 997 kg/m³ density
 ** Curve tolerance according to ISO 9906:2012 Grade 3B.

Performance Curve

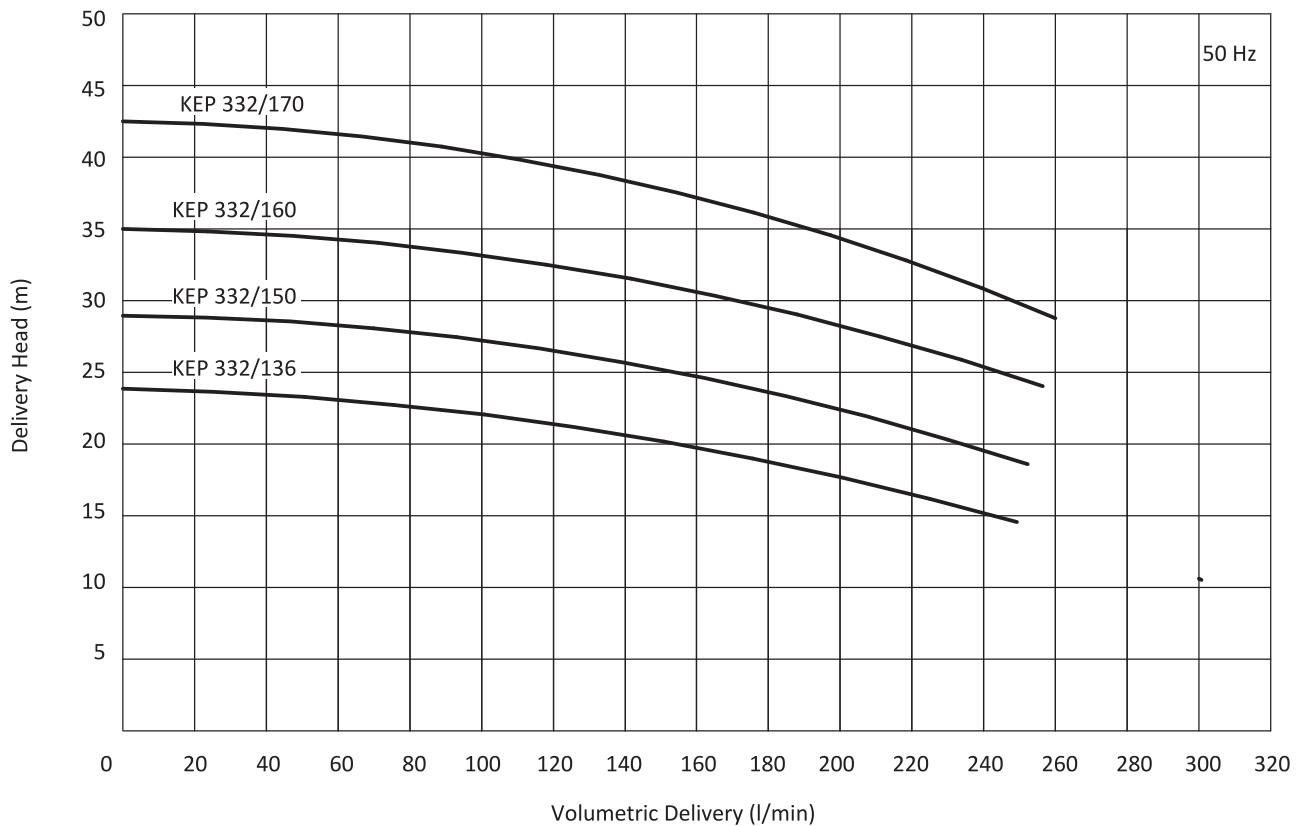

KEP 450 PUMP



Applications:

- Cutting, turning, milling, boring, grinding and similar applications of the machine tools,
- Filtration systems,
- Circulation systems.
- KEP Pumps are used for pumping of cutting / cooling fluids.

Fluid Specifications:

- Coolants,
- Cutting oils,
- Grinding oils,
- Water
- Chip containing liquids (max. 12 mm)
- Fluid temperature 0...60 °C
- Kinematic viscosity 1...30 mm²/s

Materials:

Pump body	: Cast iron - DIN GG25
Motor Flange	: Cast iron - DIN GG25
Impeller	: Cast iron - DIN GG25
Shaft	: Stainless steel - AISI 420 (DIN 1.4021)
Mechanical Seal	: C-SiC-Viton
Electric motor	: 3 phase induction motor - 2 pole Optionally 4-pole, Protection degree IP 54

Suction Head and Priming Time

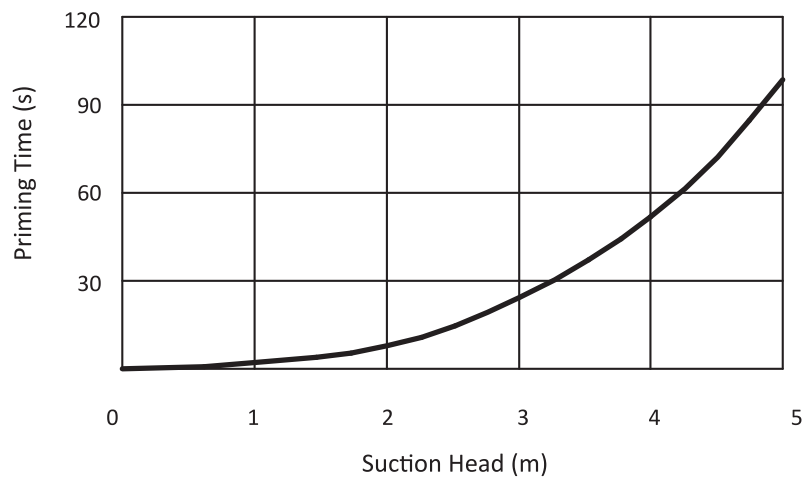

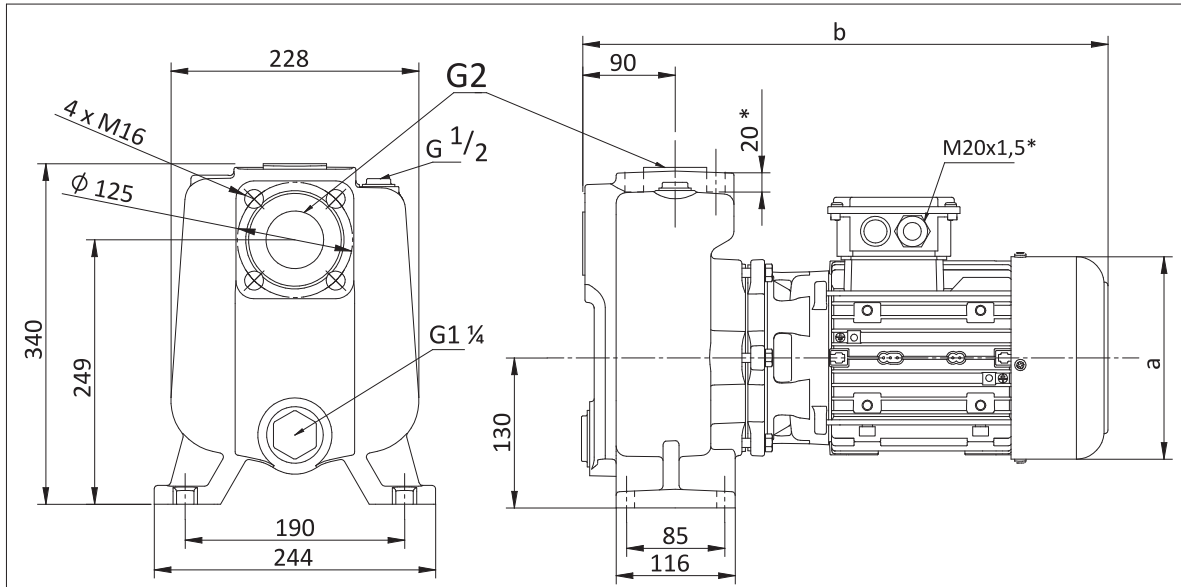

DIMENSIONS & NOMINAL VALUES

TYPE	a	b	Weight kg	Power kW	Voltage V(Δ/Y)	Frequency Hz	Rated current A	Speed rpm
	mm							
KEP 450/135-4	176	485	44	1.1	230/400	50	4,85/2,8	1440
KEP 450/120			45	2.2			7.79/4.5	2905
KEP 450/128	194	515	52	3.0			10.39/6.0	2905
KEP 450/135			54	4.0			13.68/7.9	2900

* The performance curves are based on 1 mm²/s (cSt) kinematic viscosity values and 997 kg/m³ density
 ** Curve tolerance according to ISO 9906:2012 Grade 3B.

Performance Curve

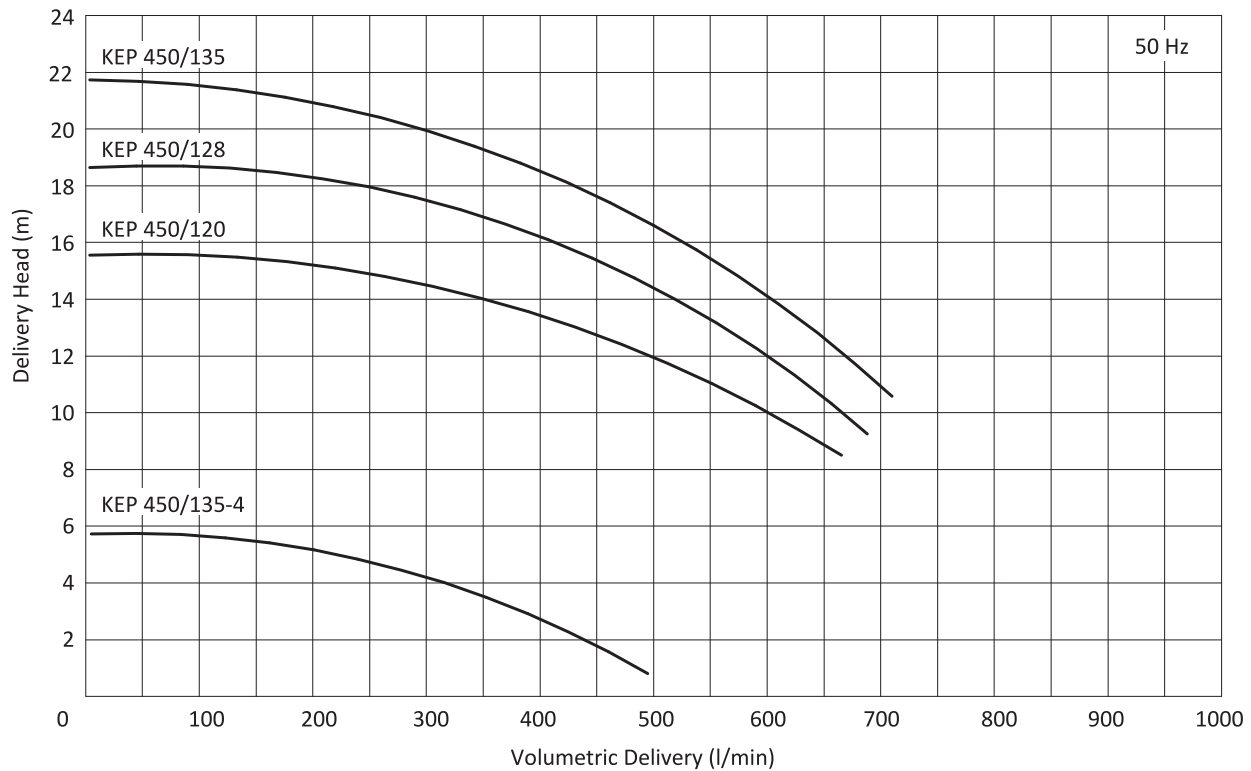

LP SERIES PUMPS

LP series pumps designed as a single stage and pumps inlet and outlet port is aligned (inline design). Therefore pump has compact design and requires small installation space.

Application Fields;

- Filter systems and recirculation applications,
- Contaminated liquids,
- Liquids containing solid particles,
- Surface washing, cleaning, degreasing,
- Machine-tool industry,
- Air-conditioning systems,
- Circulation of coolant,

Fluids;

- Water,
- Emulsions,
- Cutting oils,

Specifications;

- Due to the compact design lower installation space required.
- No back flow valve required.
- Chip size max. 8 mm,
- Easy to discharge the fluid via drain plug.
- All pumps include single mechanical seal.

Materials;

Pump Body	- GG 25
Motor Flange	- GG 25
Impeller	- GG 25
Pump Shaft	- AISI 420
Mechanical Seal	- SiC-SiC-Viton
	- TC-TC-Viton (optional for grinding app.)
O - ring	- Viton

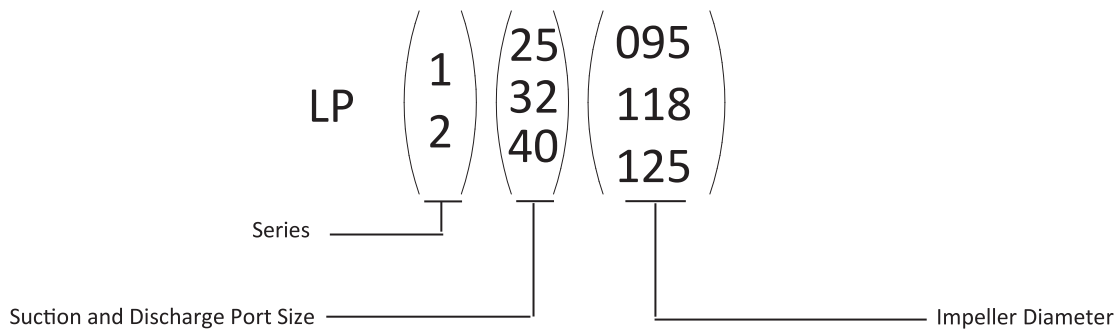

Figure 32 - LP Series Pumps

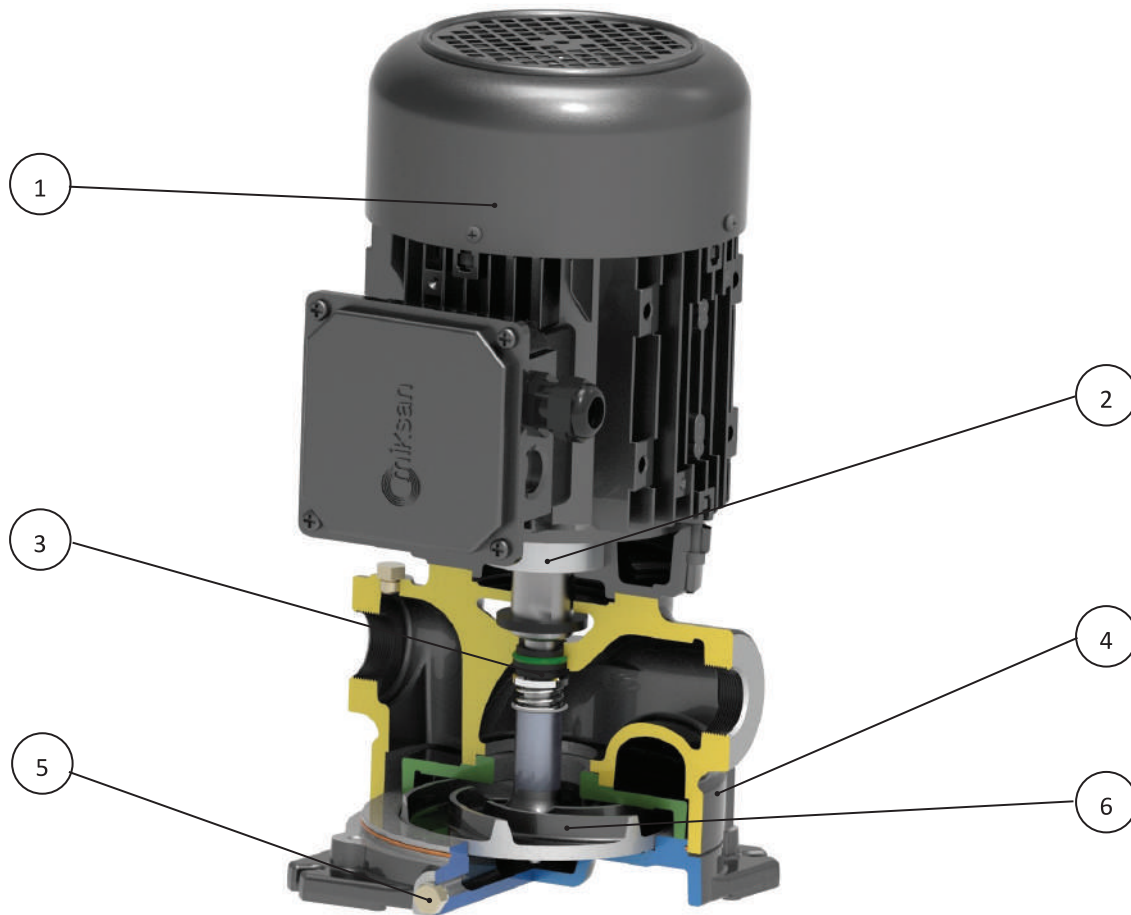

Figure 33 - LP Series Pumps Section View

1. Electric Motor

Special shaft and flange mounted electric motors are used on LP series. Impeller is directly mounted to the motor shaft.

Power of 3 phase electric motors are 2,2 kW and 1,5 kW in frame size of 90; 1,1 kW in frame size of 80; 0,75 kW and 0,55 kW in the frame size of 71; 0,37 kW and 0,25 kW in frame size of 63.

2. Bearings

Motor flange is made of cast iron and the front bearing is bigger than standard electric motors so it offers increased strength against to axial forces.

3. Mechanical Seal

Standard mechanical seal material is SiC-SiC-Viton. TC-TC-Viton mechanical seal is available upon request.

4. Pump Body

Compact design requires lower installation space.

5. Drain Plug

The fluid inside the pump can easily discharge via drain plug without dismantling the pump from the system.

6. Impeller

Special impeller design provides high efficiency.

LP 125 PUMP



Applications:

- Machine tools,
- Filtration systems,
- Circulation systems,
- Air conditioning systems,

Fluid Specifications:

- Coolants,
- Cutting oils,
- Grinding oils,
- Water
- Chip containing liquids (max. 5 mm)
- Fluid temperature 0...60 °C
- Kinematic viscosity 1...90 mm²/s

Materials:

Pump body	: Cast iron - DIN GG25
Motor Flange	: Cast iron - DIN GG25
Impeller	: Cast iron - DIN GG25
Shaft	: Stainless steel - AISI 420 (DIN 1.4021)
O-ring	: Viton
Mechanical Seal	: SiC-SiC-Viton
	: TC-TC-Viton (optional for grinding application)
Electric motor	: 3 phase induction motor
	2 pole
	Protection degree IP 54



DIMENSIONS & NOMINAL VALUES

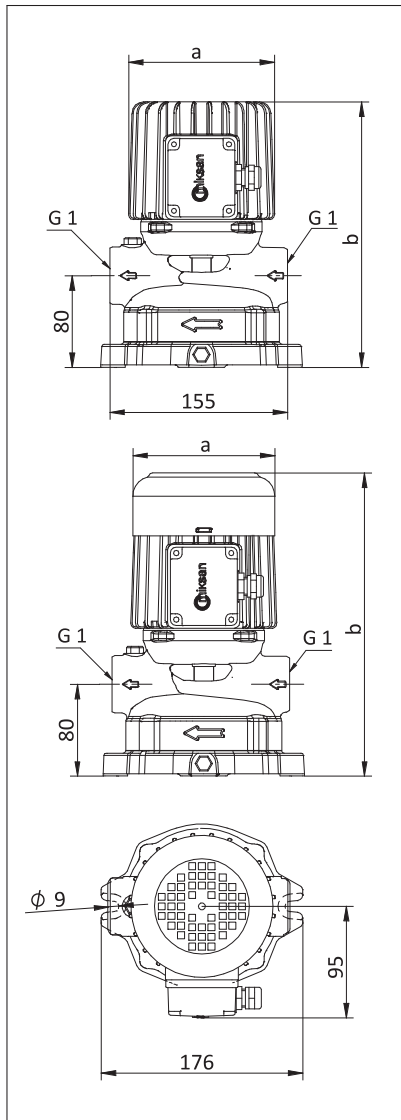

TYPE	a	b	Weight kg	Power kW	Voltage V(Δ/Y)	Frequency Hz	Rated current A	Speed rpm
	mm							
LP 125/088	127	232	9.0	0.25	230/400	50	1.26/0.73	2760
LP 125/095	124	265	9.5	0.37			2.16/1.25	2820

* The performance curves are based on 1 mm²/s (cSt) kinematic viscosity values and 997 kg/m³ density.

** Curve tolerance according to ISO 9906:2012 Grade 3B.

*** LP 125/088 is provided without coolant fan.

Performance Curve

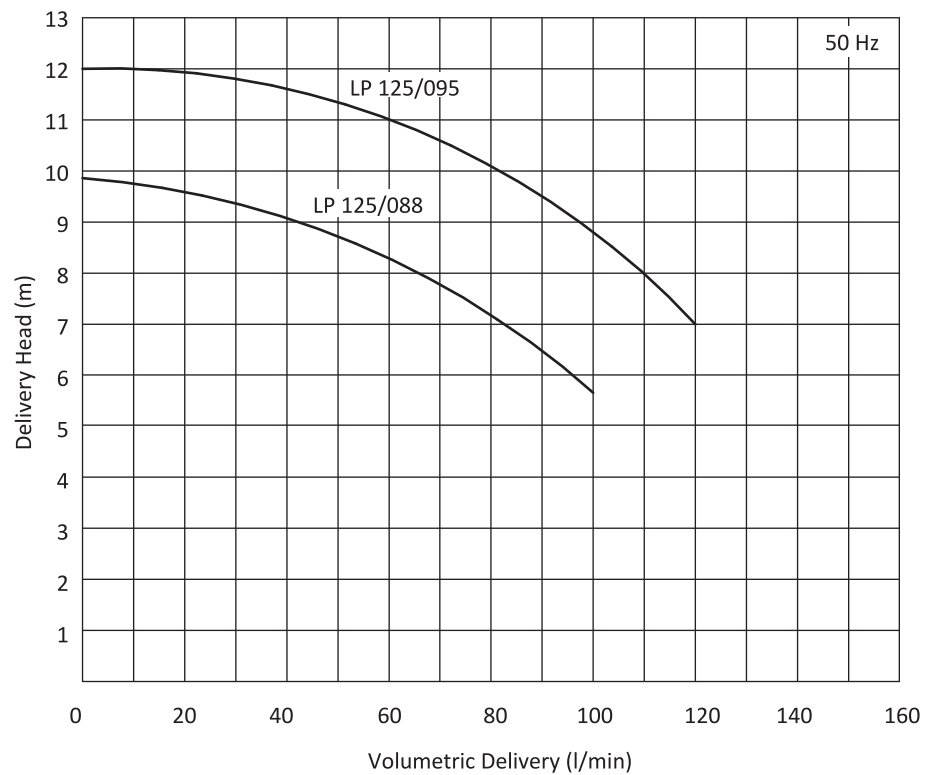



LP 225 PUMP

Applications:

- Machine tools,
- Filtration systems,
- Circulation systems,
- Air conditioning systems,

Fluid Specifications:

- Coolants,
- Cutting oils,
- Grinding oils,
- Water
- Chip containing liquids (max. 5 mm)
- Fluid temperature 0...60 °C
- Kinematic viscosity 1...90 mm²/s

Materials:

Pump body	: Cast iron - DIN GG25
Motor Flange	: Cast iron - DIN GG25
Impeller	: Cast iron - DIN GG25
Shaft	: Stainless steel - AISI 420 (DIN 1.4021)
O-ring	: Viton
Mechanical Seal	: SiC-SiC-Viton
	: TC-TC-Viton (optional for grinding application)
Electric motor	: 3 phase induction motor
	2 pole, 2900 rpm
	Protection degree IP 54

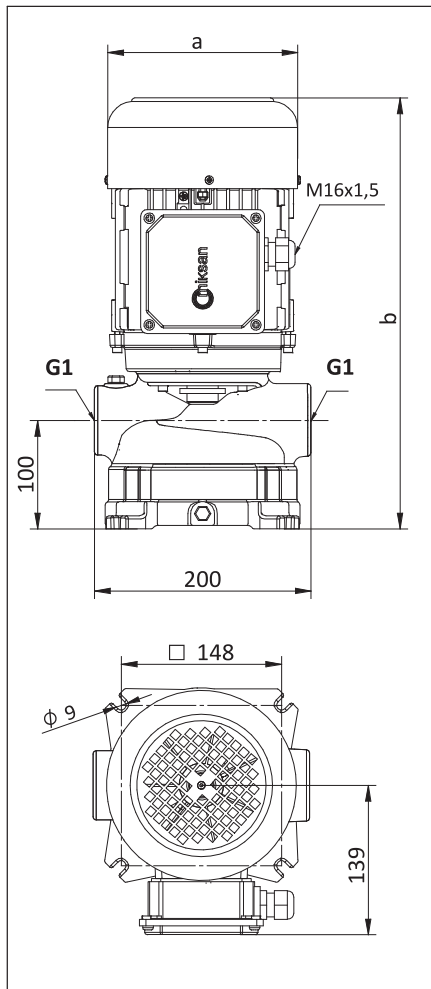

DIMENSIONS & NOMINAL VALUES

TYPE	mm			Weight	Power	Voltage	Frequency	Rated current	Speed
	a	b	c	kg	kW	V(Δ/Y)	Hz	A	rpm
LP 225/110	138	350	111	17.0	0.55	230/400	50	2.25/1.3	2780
LP 225/118				17.5	0.75			3.12/1.8	2820
LP 225/125	157	380	118	20.0	1.10			4.16/2.4	2890

* The performance curves are based on 1 mm²/s (cSt) kinematic viscosity values and 997 kg/m³ density

** Curve tolerance according to ISO 9906:2012 Grade 3B.

Performance Curve

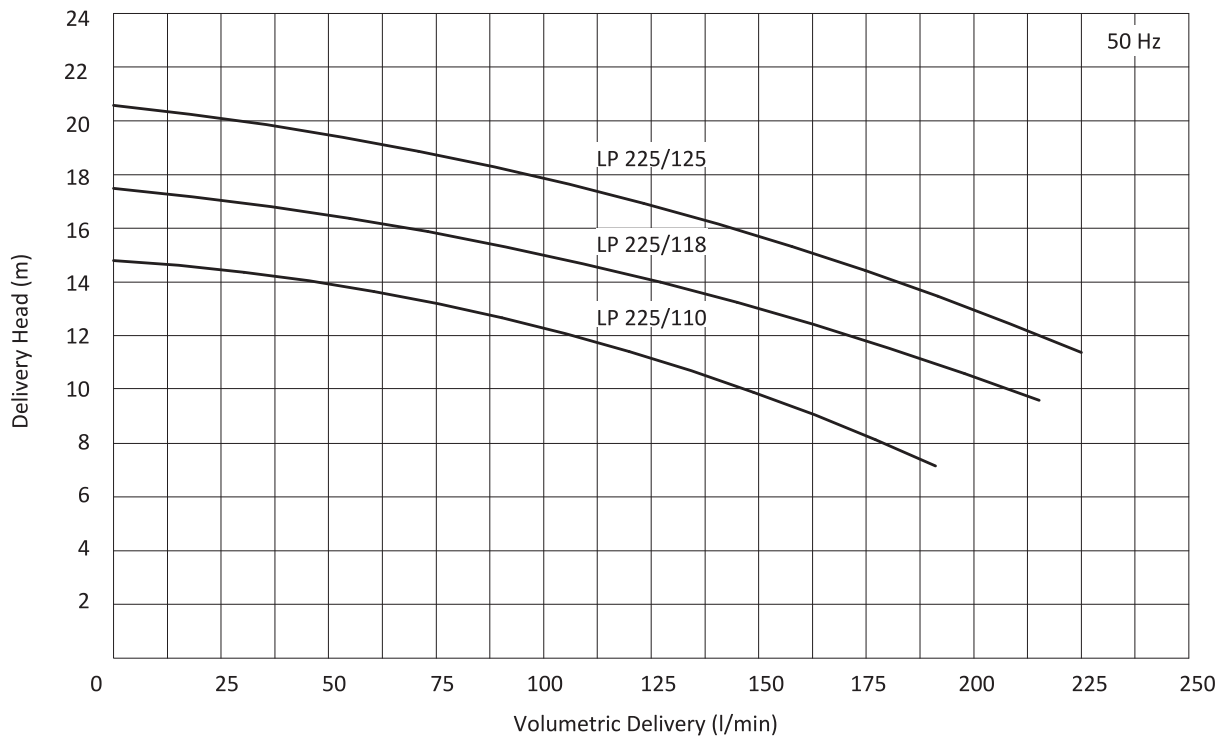



LP 232 PUMP

Applications:

- Machine tools,
- Filtration systems,
- Circulation systems,
- Air conditioning systems,

Fluid Specifications:

- Coolants,
- Cutting oils,
- Grinding oils,
- Water
- Chip containing liquids (max. 8 mm)
- Fluid temperature 0...60 °C
- Kinematic viscosity 1...90 mm²/s

Materials:

Pump body	: Cast iron - DIN GG25
Motor Flange	: Cast iron - DIN GG25
Impeller	: Cast iron - DIN GG25
Shaft	: Stainless steel - AISI 420 (DIN 1.4021)
O-ring	: Viton
Mechanical Seal	: SiC-SiC-Viton
	: TC-TC-Viton (optional for grinding application)
Electric motor	: 3 phase induction motor
	2 pole
	Protection degree IP 54

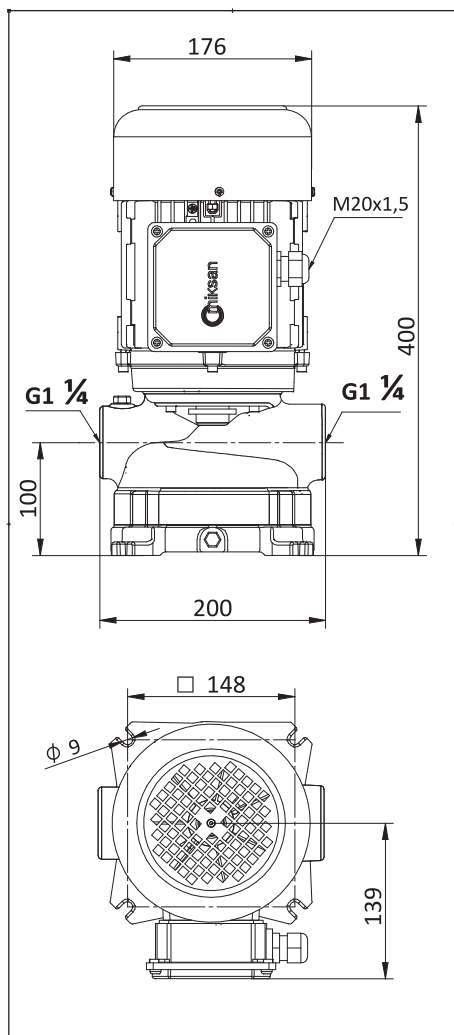

DIMENSIONS & NOMINAL VALUES

	Weight	Power	Voltage	Frequency	Rated current	Speed
TYPE	kg	kW	V(ΔY)	Hz	A	rpm
LP 232/125	23.5	1.5	230/400	50	5.72/3.3	2910

* The performance curves are based on 1 mm²/s (cSt) kinematic viscosity values and 997 kg/m³ density
 ** Curve tolerance according to ISO 9906:2012 Grade 3B.

Performance Curve

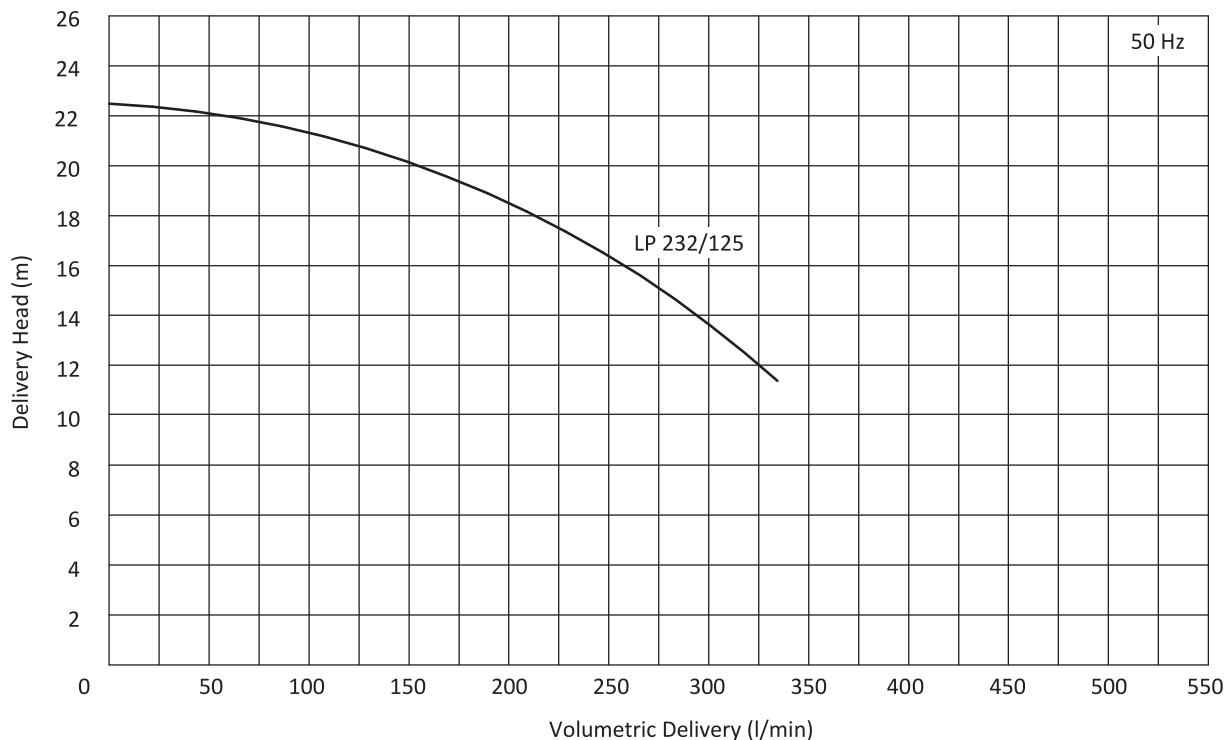



LP 240 PUMP

Applications:

- Machine tools,
- Filtration systems,
- Circulation systems,
- Air conditioning systems,

Fluid Specifications:

- Coolants,
- Cutting oils,
- Grinding oils,
- Water
- Chip containing liquids (max. 8 mm)
- Fluid temperature 0...60 °C
- Kinematic viscosity 1...90 mm²/s

Materials:

Pump body	: Cast iron - DIN GG25
Motor Flange	: Cast iron - DIN GG25
Impeller	: Cast iron - DIN GG25
Shaft	: Stainless steel - AISI 420 (DIN 1.4021)
O-ring	: Viton
Mechanical Seal	: SiC-SiC-Viton
	: TC-TC-Viton (optional for grinding application)
Electric motor	: 3 phase induction motor
	2 pole
	Protection degree IP 54

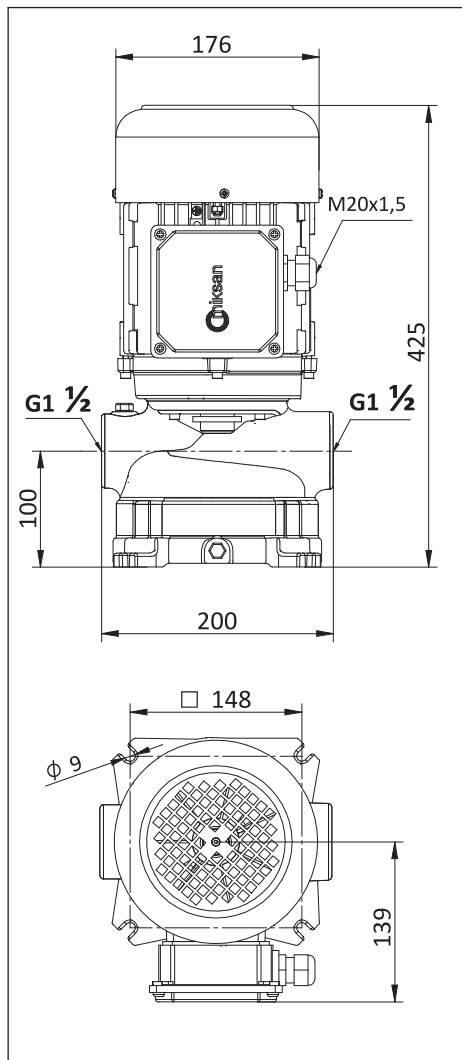

DIMENSIONS & NOMINAL VALUES

	Weight	Power	Voltage	Frequency	Rated current	Speed
TYPE	kg	kW	V(Δ/Y)	Hz	A	rpm
LP 240/125	26.0	2.2	230/400	50	7.79/4.5	2905

* The performance curves are based on 1 mm²/s (cSt) kinematic viscosity values and 997 kg/m³ density
 ** Curve tolerance according to ISO 9906:2012 Grade 3B.

Performance Curve

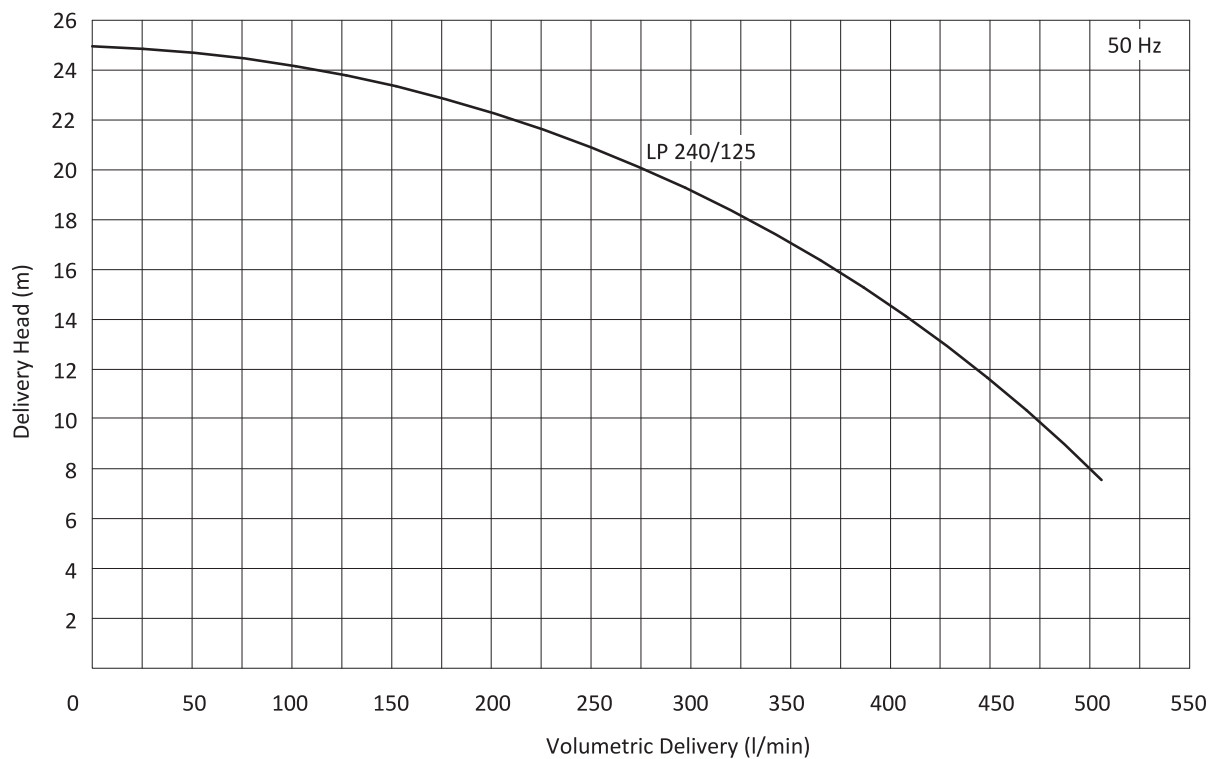

DP SERIES PLASTIC PUMP

DP series plastic pumps can be used traditional machine tools applications. But also, it is perfectly suitable for clean water and chemical solutions because of the pump's materials.

Materials of the pump parts;

- Pump body : PPS
- Stages : PPS
- Diffusers : PPS
- Impellers : PPS
- Cover: PPS
- Axial Impellers: PPS
- Bushing : PPS
- Shaft : DIN 1.4301 (AISI 304)
- Strainer (Optional): PE
- Bearing Rings : Tungsten Carbide - Ceramic

There are three different pump at same modular design;

- 1 - DP 60 Series : $Q_{max} = 60$ l/min , $H_{max} = 6$ m (per stage)
- 2 - DP 100 Series : $Q_{max} = 110$ l/min , $H_{max} = 6$ m (per stage)
- 3 - DP 150 Series : $Q_{max} = 160$ l/min , $H_{max} = 7$ m (per stage)

DP Series pumps can be supply low and medium pressure because of their multistage design.

Specifications;

- Pump shaft is AISI 304 stainless steel as a standard.
- Perfectly suitable for chemical liquids.
- Pump materials are durable for high corrosion.
- Chip size max. 4 mm.
- Small space requirements due to the compact design.
- All pumps are seal-less.
- It can be produced with single-phase motor as an option.

Application Fields;

- Dehumidification systems,
- Liquids containing solid particles,
- Alkaline, solvents, coolants and lubricants etc.
- Surface washing, cleaning, degreasing,
- Recycling in Machine-tool industry,
- Circulation of coolant,
- Circulation beverage systems,
- Printing industry.



Figure 34- DP Series Pumps



Figure 35- DP Series Exploded View

Pump Parts :

1. Electric Motor
2. Pump Body
3. Stages
4. Diffuser
5. O-ring
6. Impeller
7. Cover
8. Axial impeller
9. Strainer



DP 60 PUMP

Applications:

- Circulation systems,
- Beverage industry,
- Printing industry.

Fluid Specifications:

- Coolants,
- Cutting oils,
- Chemical solutions,
- Distilled or deionize water,
- Chip contains liquids (max. 4mm)
- Fluid temperature 0...60 °C
- Kinematic viscosity 1...12 mm²/s

Materials:

Pump body	: PPS
Stages	: PPS
Diffusers	: PPS
Impeller	: PPS
Cover	: PPS
Axial impeller	: PPS
Strainer (Optional)	: PE
Pump shaft	: Stainless steel - AISI 304 (DIN 1.4301)
Electric motor	: 3 phase induction motor 1 phase induction motor (Optional) 2 pole, 2900 rpm Protection degree IP 54

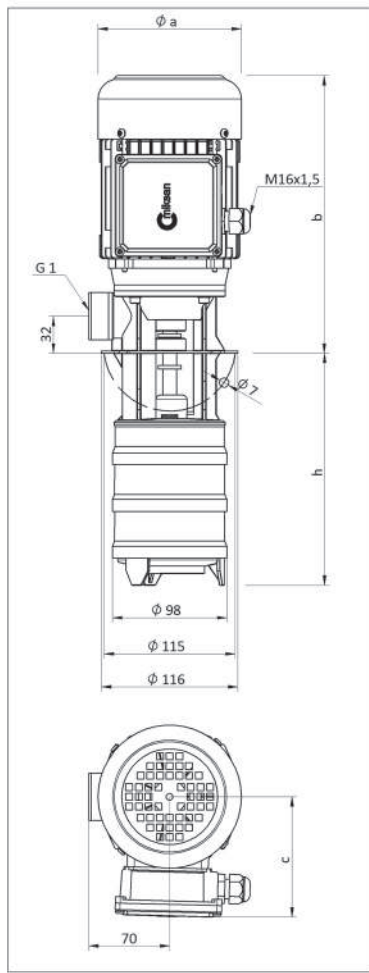

DIMENSIONS & NOMINAL VALUES

TYPE	Depth of Immersion h (mm)	mm			Weight kg	Power kW	Voltage V(Δ/Y)	Frequency Hz	Rated current A	Speed rpm
		a	b	c						
DP 61/120	120	113	216	87	3.2	0.09	230/400	50	0.48/0.28	2830
DP 61/170	170				3.3					
DP 61/220	220				3.4					
DP 61/270	270				3.5					
DP 62/160	160	113	216	87	3.9	0.15	230/400	50	0.80/0.46	2850
DP 62/210	210				4.0					
DP 62/260	260				4.1					
DP 62/310	310				4.2					
DP 63/200	200	124	240	104	4.6	0.25	230/400	50	1.26/0.73	2760
DP 63/250	250				4.7					
DP 63/300	300				4.8					
DP 63/350	350				4.9					
DP 64/240	240	124	240	104	5.3	0.28	230/400	50	1.73/1.0	2820
DP 64/290	290				5.4					
DP 64/340	340				5.5					
DP 64/390	390				5.6					
DP 65/280	280	124	240	104	6.1	0.37	230/400	50	2.16/1.25	2820
DP 65/330	330				6.2					
DP 65/380	380				6.3					

Performance Curve

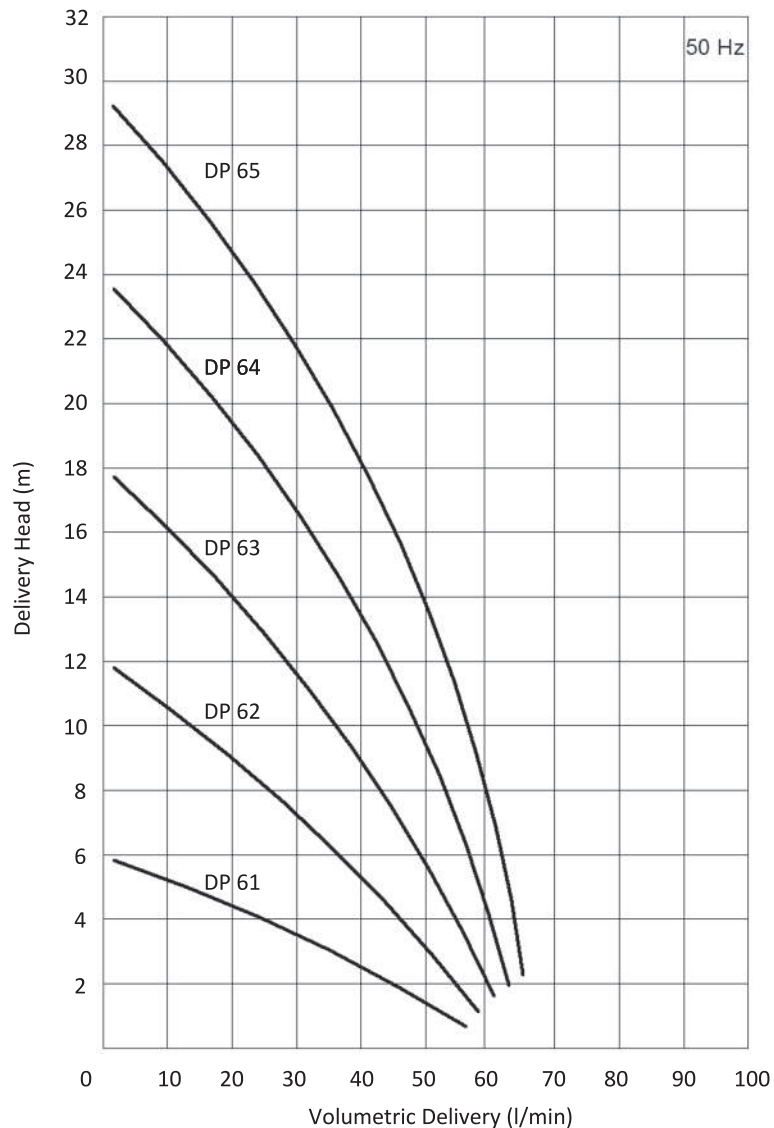

* Pump dimensions according to EN 12157.

** The performance curves are based on 1 mm²/s (cSt) kinematic viscosity values and 997 kg/m³ density

*** Curve tolerance according to ISO 9906:2012 Grade 3B.



DP 100 PUMP

Applications:

- Circulation systems,
- Beverage industry,
- Printing industry.

Fluid Specifications:

- Coolants,
- Cutting oils,
- Chemical solutions,
- Distilled or deionize water,
- Chip contains liquids (max. 4mm)
- Fluid temperature 0...60 °C
- Kinematic viscosity 1...12 mm²/s

Materials:

Pump body	: PPS
Stages	: PPS
Diffusers	: PPS
Impeller	: PPS
Cover	: PPS
Axial impeller	: PPS
Strainer (Optional)	: PE
Pump shaft	: Stainless steel - AISI 304 (DIN 1.4301)
Electric motor	: 3 phase induction motor 1 phase induction motor (Optional) 2 pole, 2900 rpm Protection degree IP 54

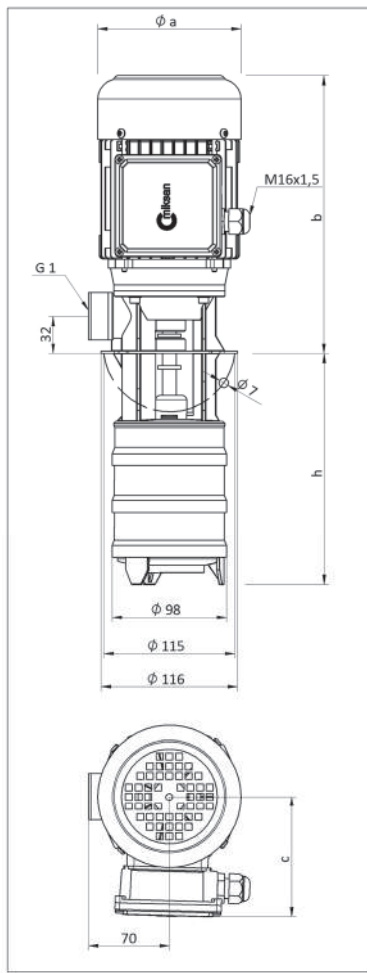

DIMENSIONS & NOMINAL VALUES

TYPE	Depth of Immersion h (mm)	mm			Weight kg	Power kW	Voltage V(Δ/Y)	Frequency Hz	Rated current A	Speed rpm
		a	b	c						
DP 101/120	120	113	216	87	3.5	0.12	230/400	50	0.61/0.35	2880
DP 101/170	170				3.6					
DP 101/220	220				3.7					
DP 101/270	270				3.8					
DP 102/160	160	113	216	87	4.0	0.18	230/400	50	0.85/0.49	2820
DP 102/210	210				4.1					
DP 102/260	260				4.2					
DP 102/310	310				4.3					
DP 103/200	200	124	240	104	4.7	0.25	230/400	50	1.26/0.73	2760
DP 103/250	250				4.8					
DP 103/300	300				4.9					
DP 103/350	350				5.0					
DP 104/240	240	124	240	104	5.4	0.37	230/400	50	2.16/1.25	2820
DP 104/290	290				5.5					
DP 104/340	340				5.6					
DP 104/390	390				5.7					
DP 105/280	280	138	265	111	7.3	0.55	230/400	50	2.25/1.3	2780
DP 105/330	330				7.4					
DP105/380	380				7.5					

Performance Curve

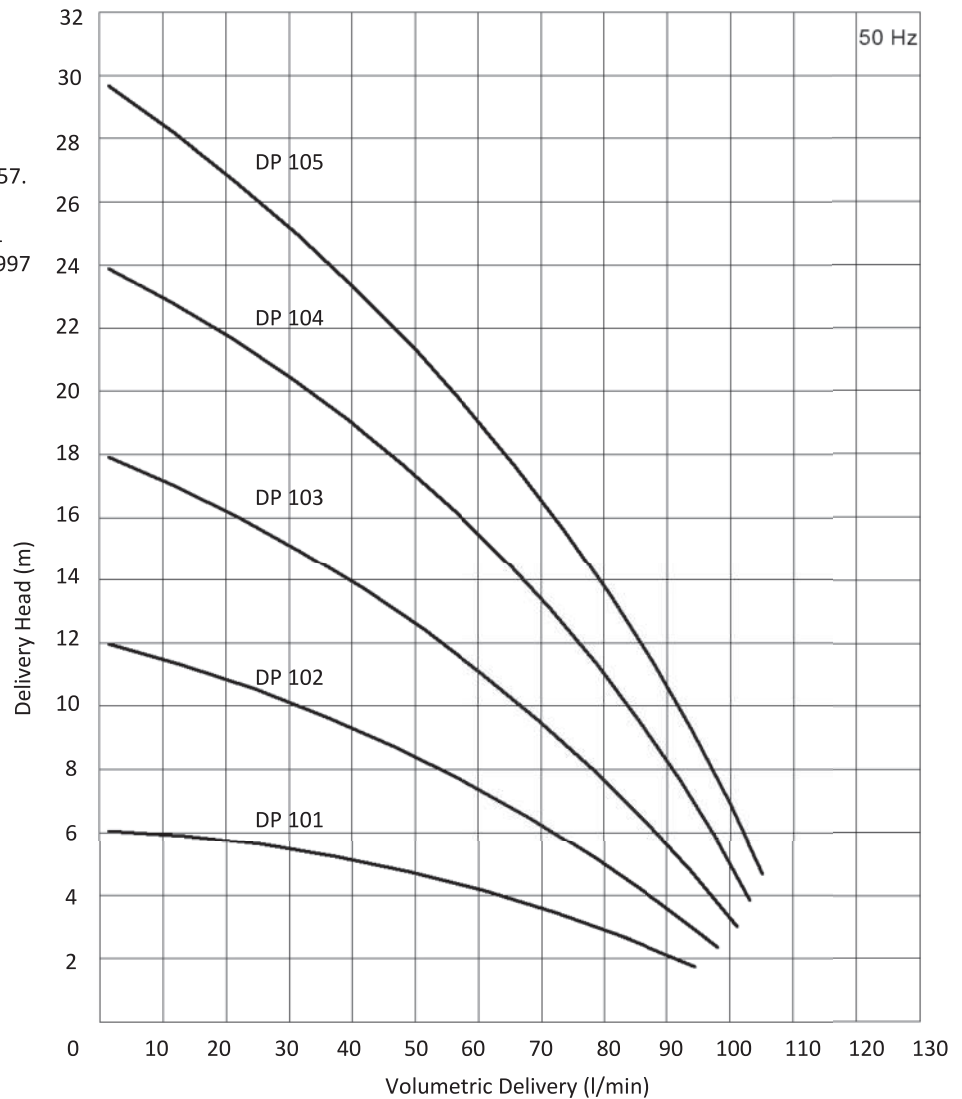

* Pump dimensions according to EN 12157.

** The performance curves are based on 1 mm²/s (cSt) kinematic viscosity values and 997 kg/m³ density

*** Curve tolerance according to ISO 9906:2012 Grade 3B.



DP 150 PUMP

Applications:

- Circulation systems,
- Beverage industry,
- Printing industry.

Fluid Specifications:

- Coolants,
- Cutting oils,
- Chemical solutions,
- Distilled or deionize water,
- Chip contains liquids (max. 4mm)
- Fluid temperature 0...60 °C
- Kinematic viscosity 1...12 mm²/s

Materials:

Pump body	: PPS
Stages	: PPS
Diffusers	: PPS
Impeller	: PPS
Cover	: PPS
Axial impeller	: PPS
Strainer (Optional)	: PE
Pump shaft	: Stainless steel - AISI 304 (DIN 1.4301)
Electric motor	: 3 phase induction motor 1 phase induction motor (Optional) 2 pole, 2900 rpm Protection degree IP 54

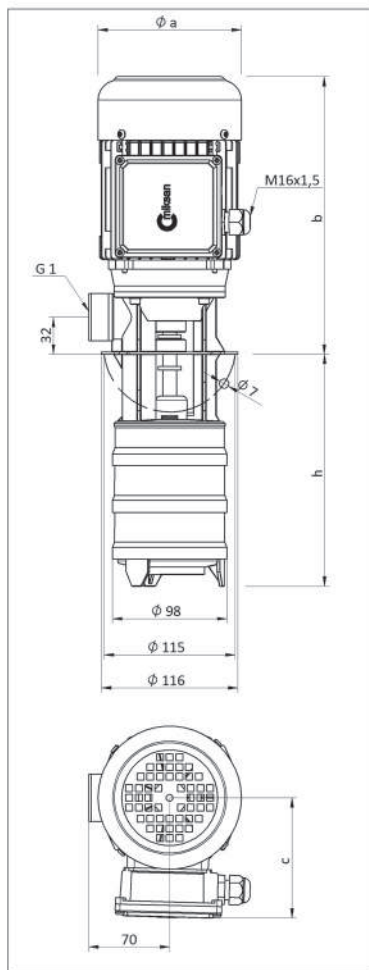

DIMENSIONS & NOMINAL VALUES

TYPE	Depth of Immersion h (mm)	mm			Weight kg	Power kW	Voltage V(Δ/Y)	Frequency Hz	Rated current A	Speed rpm
		a	b	c						
DP 151/120	120	113	216	87	3.8	0.18	230/400	50	0.85/0.49	2820
DP 151/170	170				3.9					
DP 151/220	220				4.0					
DP 151/270	270				4.1					
DP 152/160	160	124	240	104	4.9	0.37	230/400	50	2.16/1.25	2820
DP 152/210	210				5.0					
DP 152/260	260				5.1					
DP 152/310	310				5.2					
DP 153/200	200	138	265	111	7.0	0.55	230/400	50	2.25/1.3	2780
DP 153/250	250				7.1					
DP 153/300	300				7.2					
DP 153/350	350				7.3					
DP 154/240	240	138	265	111	7.1	0.55	230/400	50	2.25/1.3	2780
DP 154/290	290				7.2					
DP 154/340	340				7.3					
DP 154/390	390				7.4					
DP 155/280	280	138	265	111	8.1	0.75	230/400	50	3.12/1.8	2820
DP 155/330	330				8.2					
DP 155/380	380				8.3					

Performance Curve

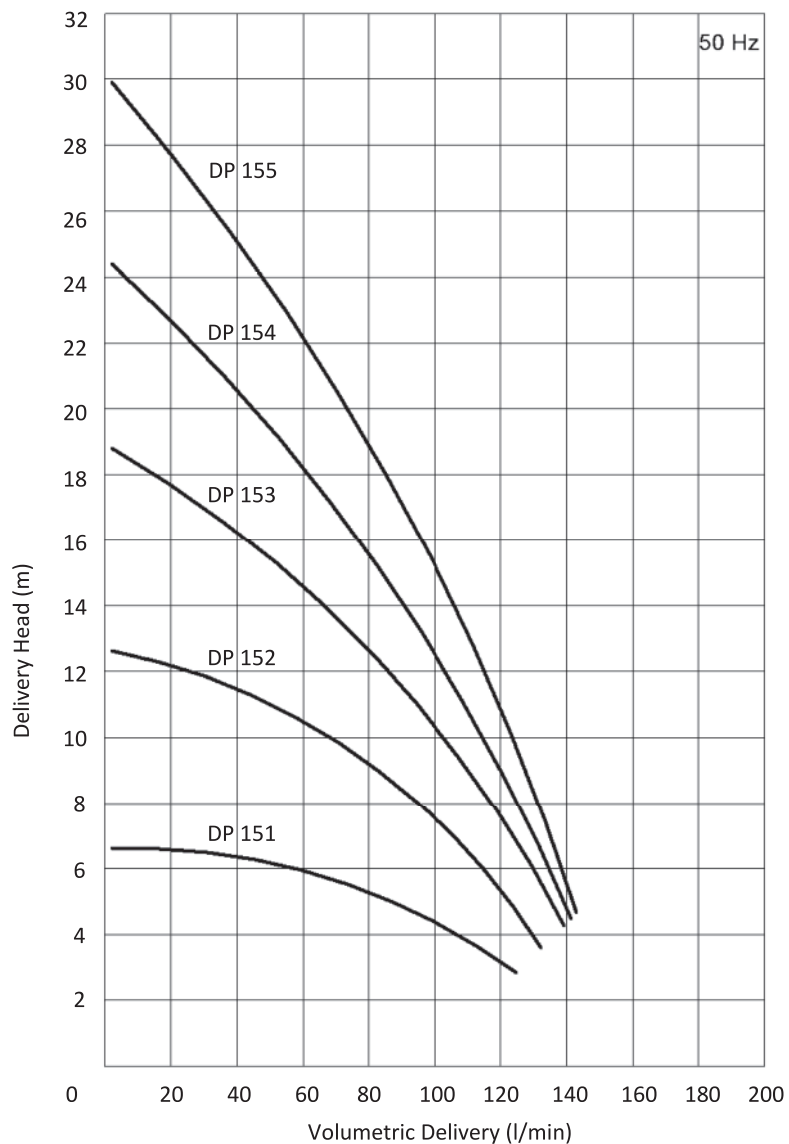

* Pump dimensions according to EN 12157.

** The performance curves are based on 1 mm²/s (cSt) kinematic viscosity values and 997 kg/m³ density

*** Curve tolerance according to ISO 9906:2012 Grade 3B.



T PUMP

Applications:

- Cutting, turning, milling, boring, grinding and similar applications of the machine tools,
- Band sawing machines,
- Circulation systems. T Pumps are used for pumping of cutting / cooling fluids.

Fluid Specifications:

- Coolants,
- Cutting oils,
- Grinding oils,
- Fluid temperature 0...80 °C
- Kinematic viscosity 1...60 mm²/s

Materials:

Pump body	: Cast iron - DIN GG 25
Volute	: Cast iron - DIN GG 25
Impeller	: Brass
Pump shaft	: Engineering steel - AISI 1040 (DIN C35)
Mechanical seal	: C - SiC - Viton
Electric motor	: 3 phase induction motor 2 pole, 2900 rpm Protection degree IP 55

DIMENSIONS & NOMINAL VALUES

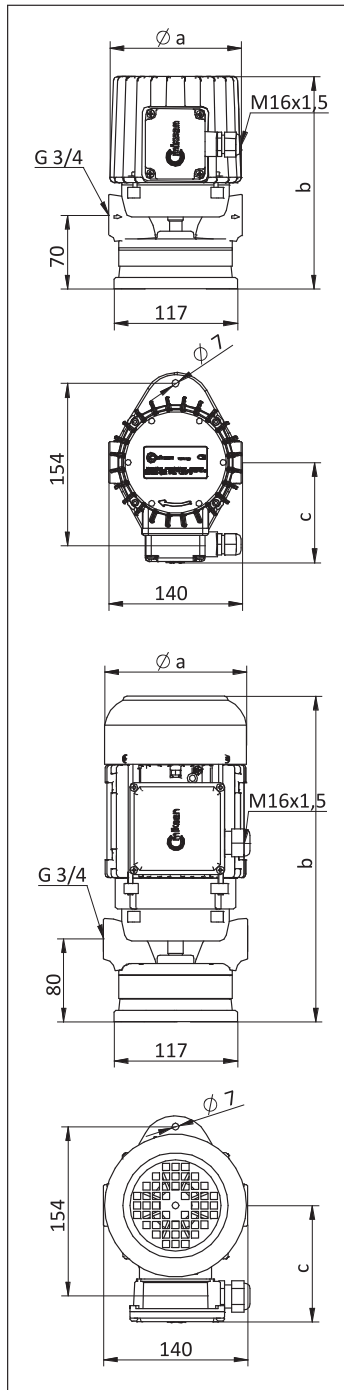

TYPE	a	b	c	Weight	Power	Voltage	Frequency	Rated current	Speed
	mm			kg	kW	V(Δ/Y)	Hz	A	rpm
T 37	127	206	95	7.2	0.25	230/400	50	1.26/0.73	2760
T 65	138	305	111	10.0	0.55			2.25/1.30	2780

- * Pump dimensions according to EN 12157.
- ** The performance curves are based on $1 \text{ mm}^2/\text{s}$ (cSt) kinematic viscosity values and 997 kg/m^3 density
- *** Curve tolerance according to ISO 9906:2012 Grade 3B

Performance Curve

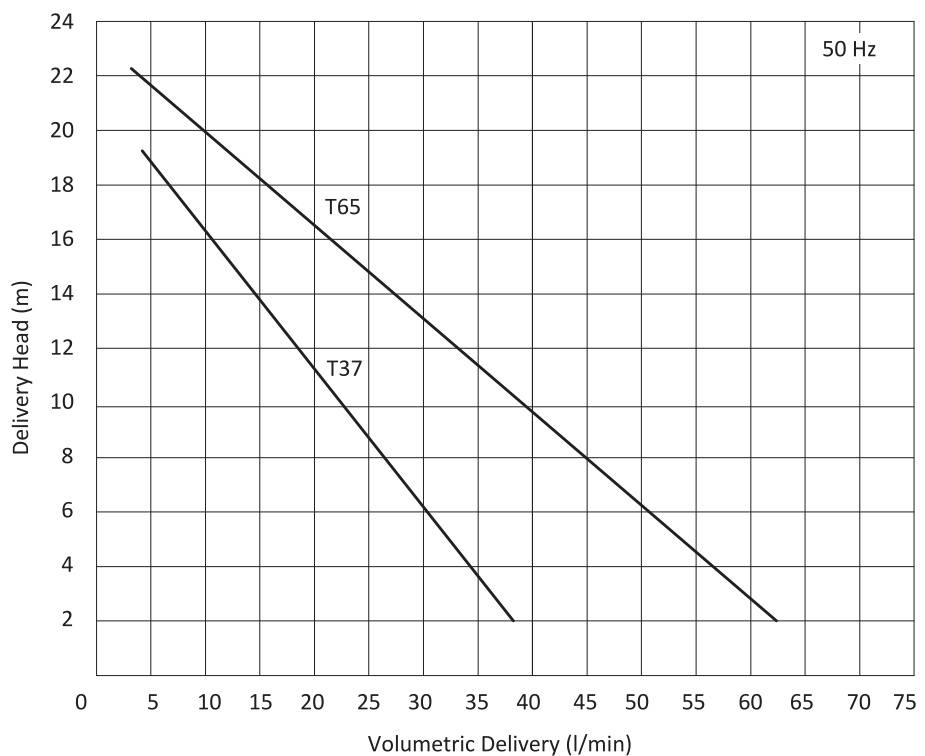



CP EX PUMP - ATEX Certificated



Applications:

- Printing machines,
- Painting processes
- CP Ex Pump is used as circulation pump at the zones which required using Ex-proof materials.
- Pump has an Ex-proof electric motor and all components of it are suitable for ATEX certificate.
- Electric motor is easily detachable with a top holder so it allow to easy washing/cleaning of pump parts before paint congeal.
- It is suitable for different paint application by using this detachable type electric motor.

Fluid Specifications:

- Paint,
- Ink,
- Fluid temperature 0...60 °C
- Kinematic viscosity 1...90 mm²/s

Materials:

Pump body	: Cast iron - DIN GG 25
Volute	: Cast iron - DIN GG 25
Impeller	: Brass
Pump shaft	: Engineering steel - AISI 1040 (DIN C35)
Electric motor	: 3 phase induction motor 2 pole, 2900 rpm Protection degree IP 55



II 2G c IIA T4

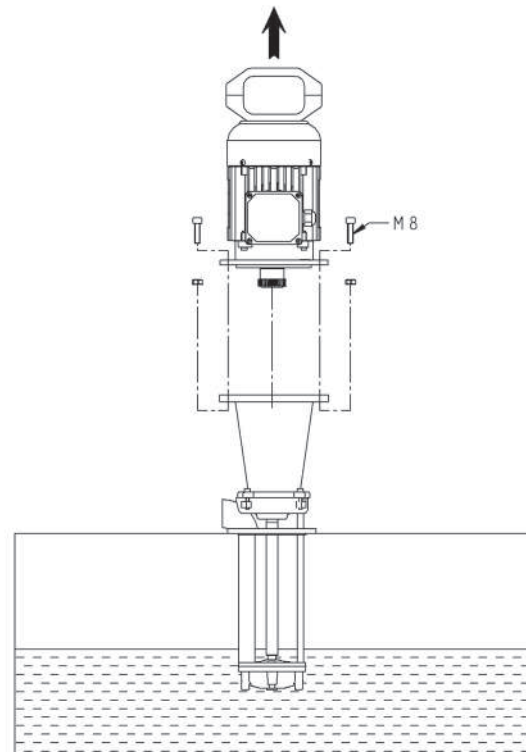

CP Ex pump with a detachable electric motor

DIMENSIONS & NOMINAL VALUES

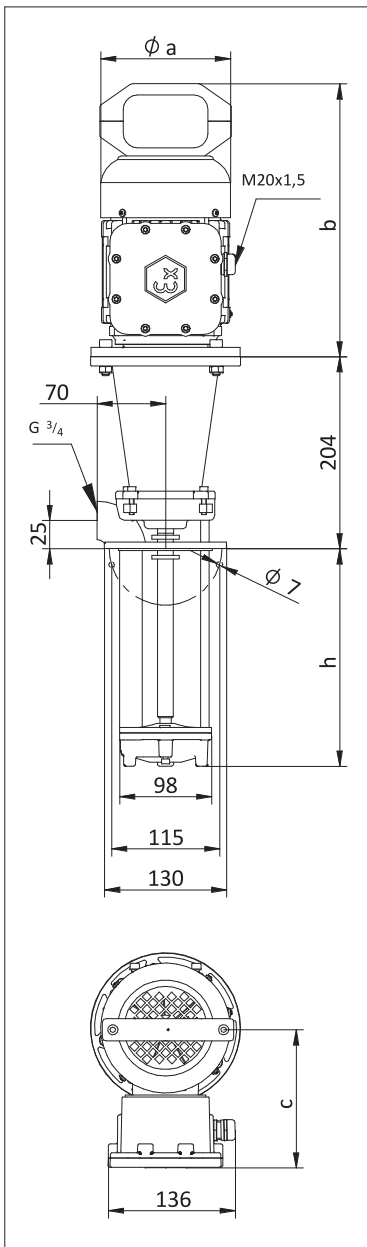

TYPE	Depth of immersion h (mm)	mm			Weight kg	Power kW	Voltage V(Δ/Y)	Frequency Hz	Rated current A	Speed rpm
		a	b	c						
CP Ex 12	130	138	290	147	13.0	0.37	230/400	50	1.9/1.1	2790
CP Ex 17	180				13.3					
CP Ex 22	230				13.5					
CP Ex 27	280				13.9					
CP Ex 35	350				14.5					

* Pump dimensions according to EN 12157.

** The performance curves are based on $1 \text{ mm}^2/\text{s}$ (cSt) kinematic viscosity values and $997 \text{ kg}/\text{m}^3$ density

*** Curve tolerance according to ISO 9906:2012 Grade 3B.

Performance Curve

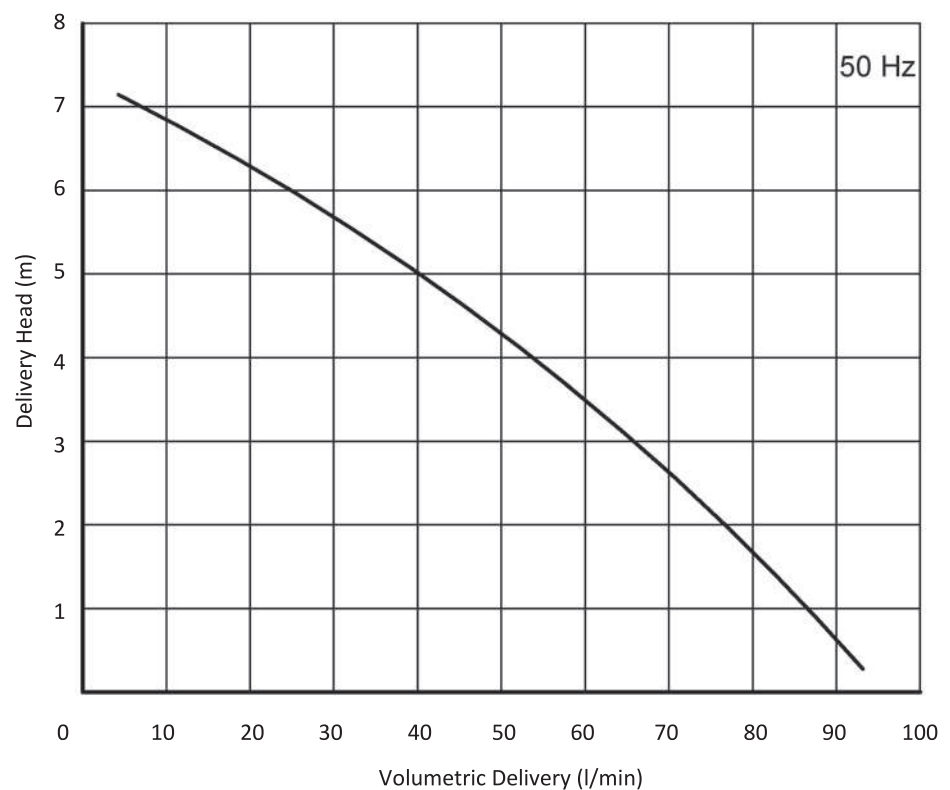

VP SERIES SCREW PUMPS

VP series pumps provide high pressure (up to 100 bar) at low volumetric delivery (up to 50lt/min).

VP Screw pumps are mostly used on deep hole drilling applications on CNC machine tools. On deep hole drilling applications, while work-piece are drilled by cutting tool, coolant liquid are sprayed to the work-piece through the cutting tool. So work-piece and cutting tool can be cooled and metal chips can be thrown out enhancing the quality of machining. It also accelerates the process and prolongs the lifetime of cutting tool. Only high pressure pumps can overcome the high flow resistance of the system and provide required flow rate.

The medium is compressed by a set of spindles in VP series self-priming pumps. Rotation of the driving (main) screw provides the pumped medium to move continuously from suction to the discharge port. The special profile formation of the spindles leads to a minimum leakage between the spindles and provides a high level of efficiency. VP series screw pumps have a pressure control and a regulation valve that is required for the safety of the system.

VP series features:

- High efficiency,
- High reliability,
- Low noise level,
- Self-priming capacity,
- Near-zero pulsation.

Primary application areas of VP series screw pumps:

- Machine tools and machining centres,
 - Pumping of the coolant and lubricant fluid (minimum 5% oil)
 - Deep hole drilling applications for cooling machine tool and work-piece and to remove the chips out of the hole.
- Hydraulic systems,
 - Pumping for coolants and fluids with high viscosity (between 1-400 cSt)
- Central units for heat exchange and energy recover,
 - Circulation of the system fluid
- Due to its wear-resistant design
 - Processes that difficult to mill materials such as titanium and stainless steel,
 - High precision applications such as aerospace industry,
 - Grinding applications.

Properties of the medium Fluids with lubricating properties such as

- Oil in water emulsions with minimum 5% oil.
- Cooling and cutting oils are suggested. Also, pumped fluid should not include abrasives or long fibre components. Installation of a strainer on the suction port of the pump has to be avoided. Usage of strainer creates additional forces on the suction port of the pump and as a result power consumption of the motor increases.

- Generally acceptable contamination:
 - Maximum solids contents: 120mg/l
 - Maximum grain size: 0.05mm (50µm) for machining (turning, milling, drilling) Special values can be applied on request. Recommended filtration quality and max. solid content of pumped fluid is shown in Figure 39.
- Kinematic viscosity: 1-400 mm²/s (cSt)
- Operation temperature: 0 °C to 80 °C

VP type screw pumps are self-priming pumps with 4m geodesic suction head. Running dry and operation with closed valve is not permissible.

VP series screw pumps are delivered with tank lid, valve block and manometer shown in Figure 36.

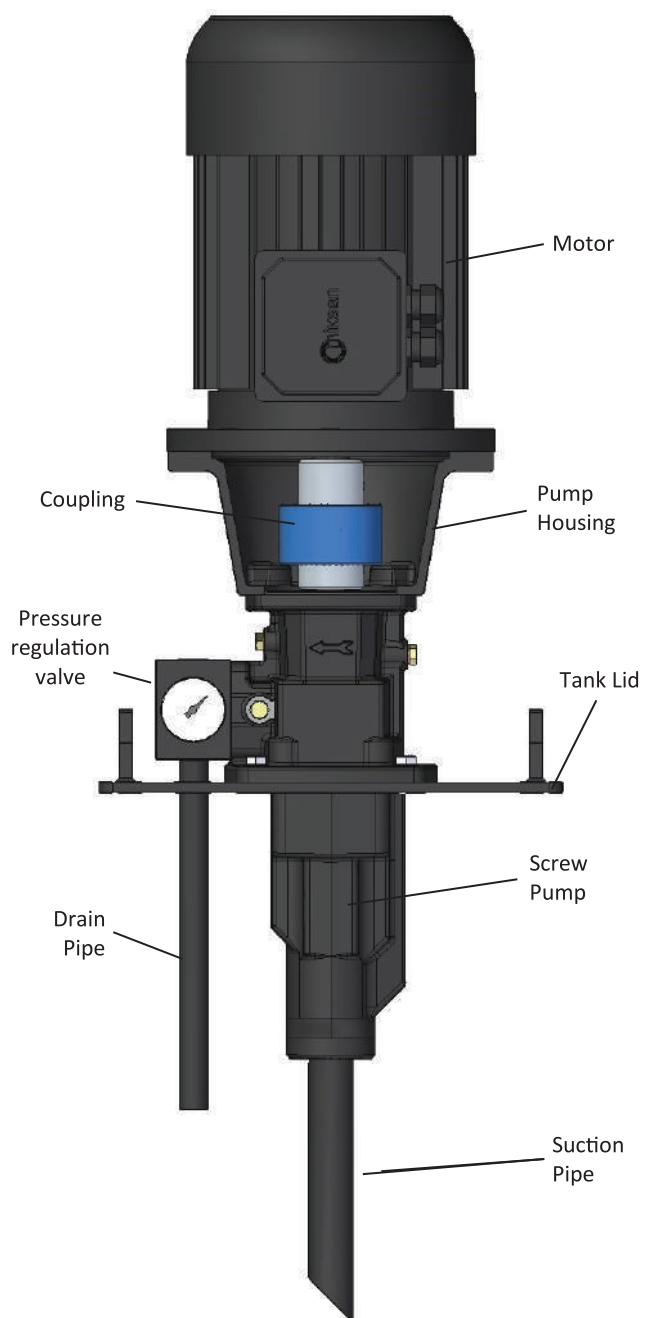
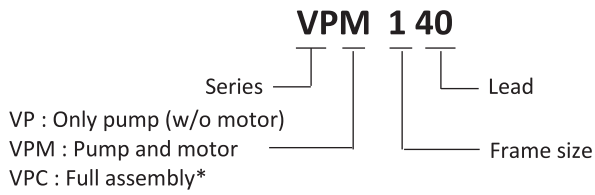

Figure 36. Configuration of VPC series screw pump

VP screw pumps are offered in various pumps within a single frame size, combination with various motors is possible. Identification of the pump is given in Figure 37.



* Full assembly includes motor, screw pump, pressure regulation valve, pressure gauge, tank lid, suction and drain valve

Figure 37. Identification of VP series screw pumps

Performance curves of the VP series screw pumps at 2900RPM and viscosity of 1 cSt is given in Figure 38. Please contact us for higher volumetric deliveries.

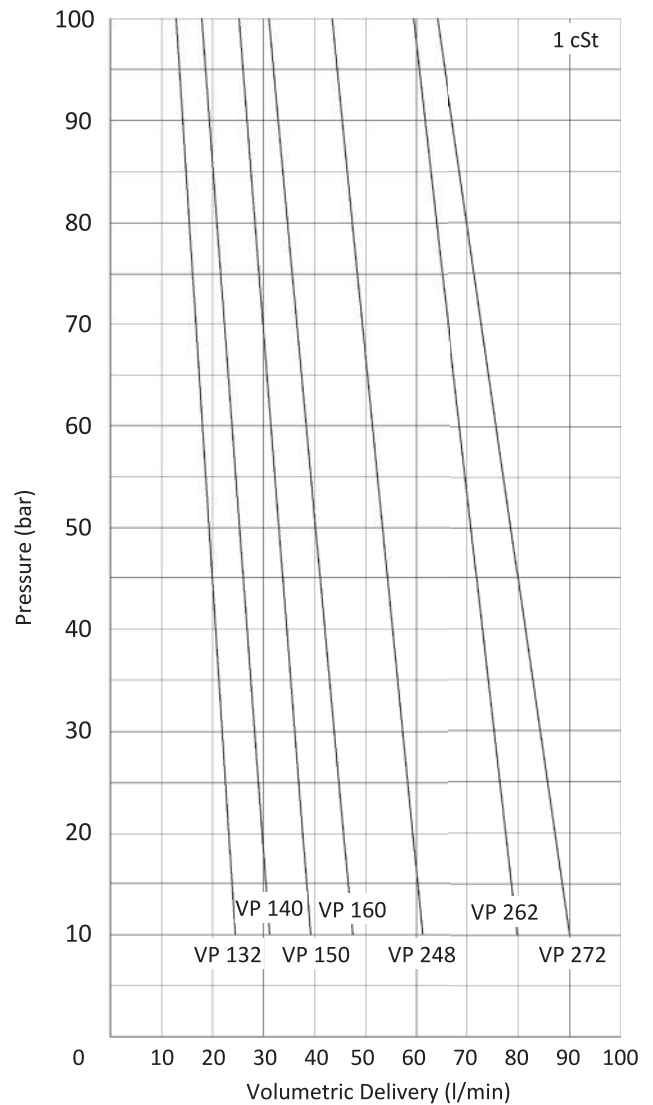

Figure 38. Performance curve of VP series screw pumps

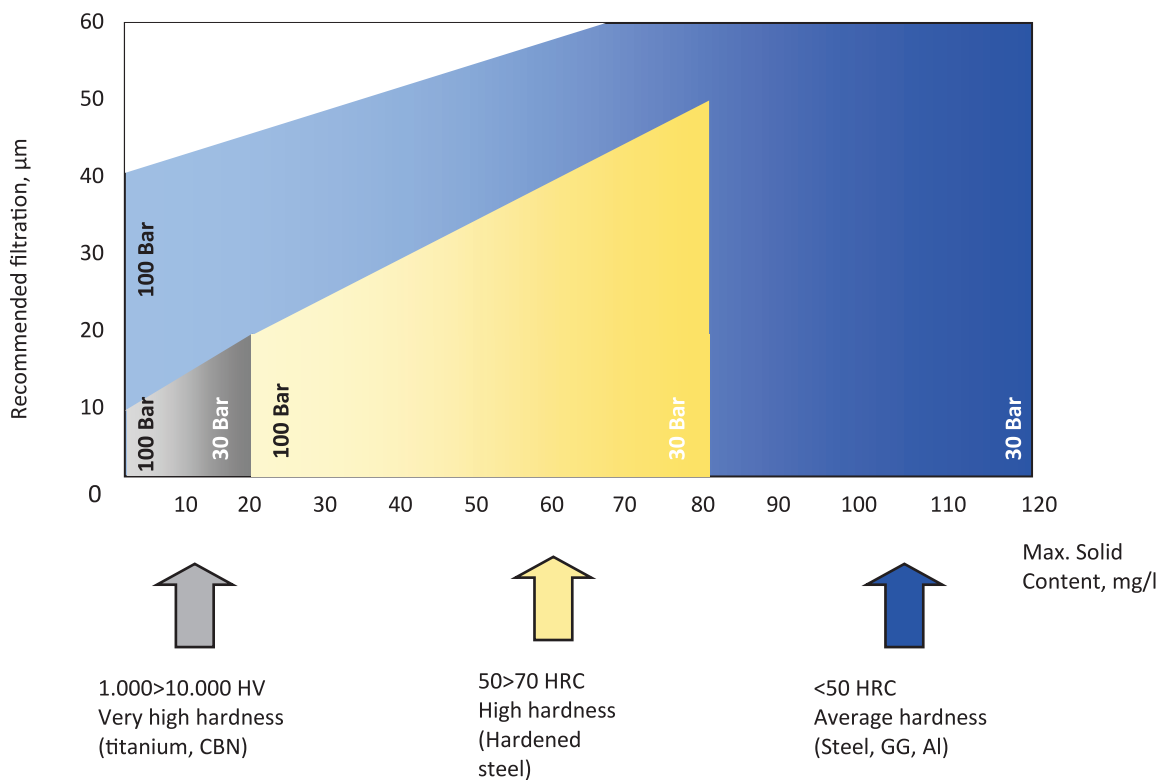

Figure 39. Recommended filtration quality of VP screw pumps

1 Screws

Special alloy steel, hardened 62 HRC, highly wear-resistant spindles extend the pump's service life

2 Housing

Special heat treatment of pump housing to minimize friction and wear

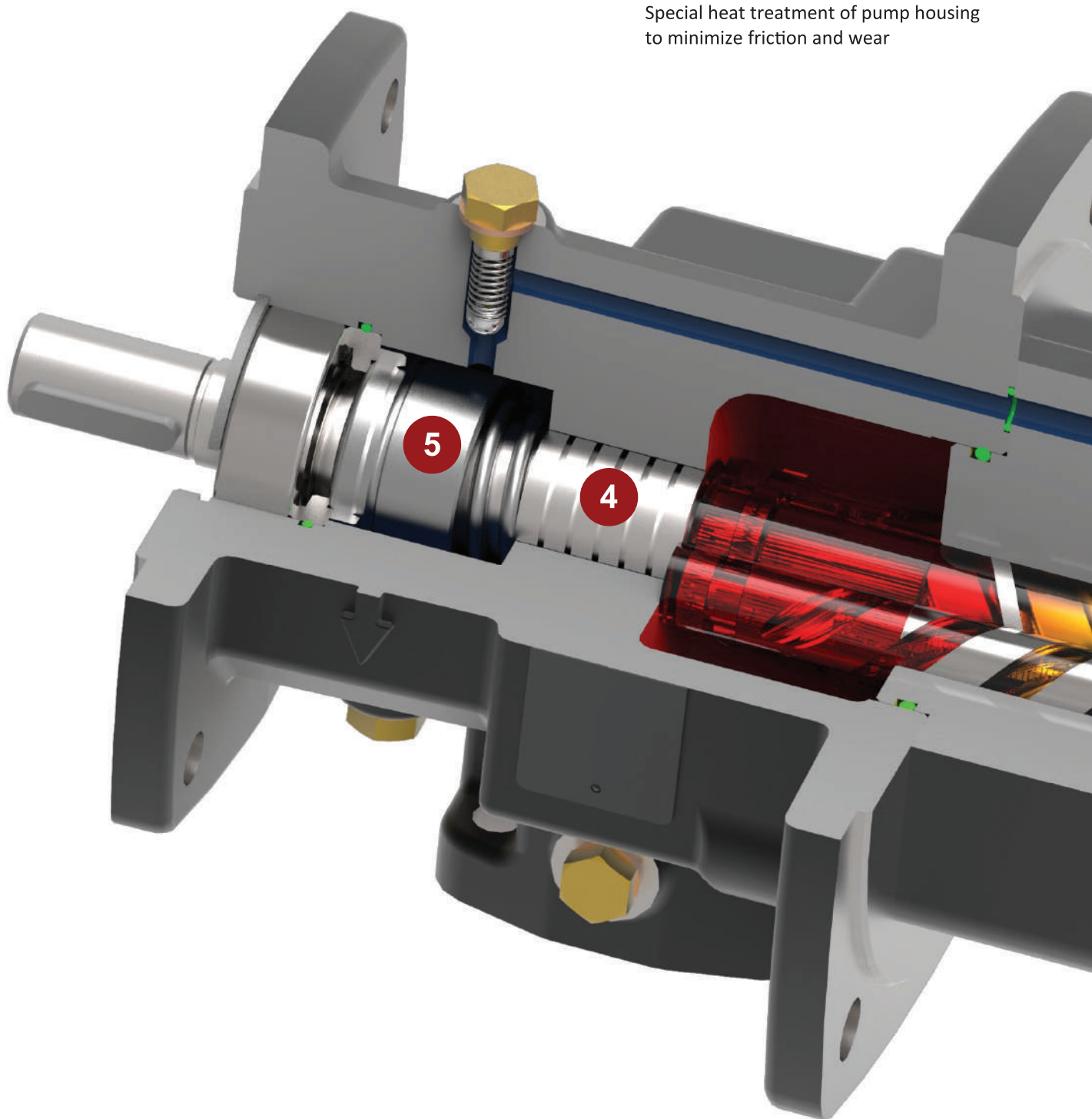

3 Seal flushing

Back-flow from seal zone to pump inlet via safety valve when pressure exceeds 0.5 Bar

5 Sealing

Maintenance-free SiC mechanical seal and Viton O-rings

4 Balancing piston

Ensures proper cooling and lubrication of mechanical seal surfaces and minimizes flow losses for higher efficiency

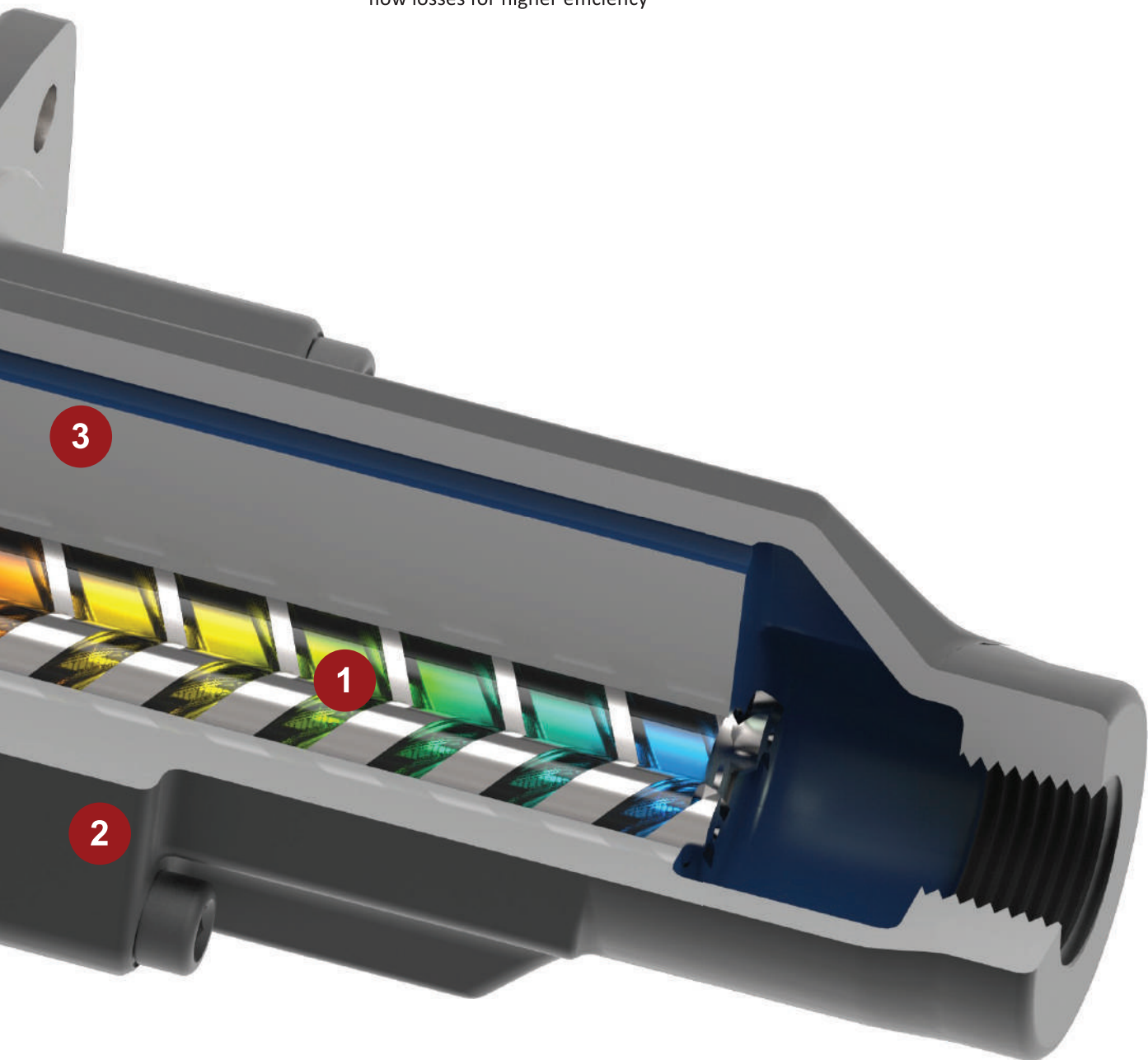

VP 132 SCREW PUMP

VPM

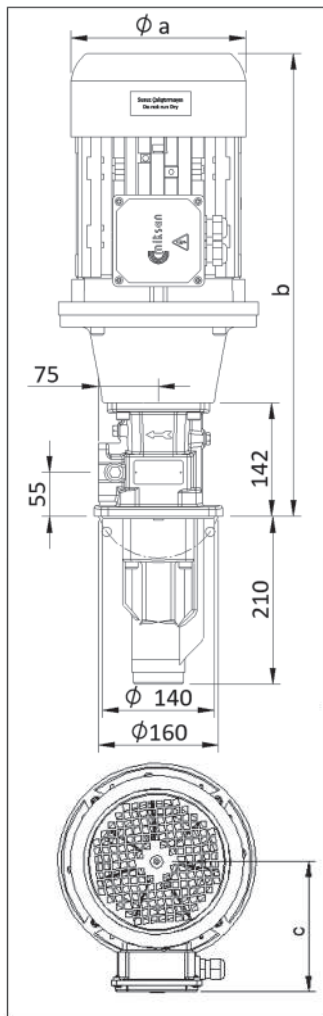

Applications:

- High pressure pumps with low volumetric delivery,
- Cutting, turning milling, boring, grinding and similar applications of the machine tools,
- Especially used for deep hole boring operations due to the high pressure up to 100 bar,
- Pumping cutting/cooling fluids in circulation systems,

Fluid Specifications:

- Coolants,
- Cutting oils,
- Grinding oils,
- Emulsions (minimum 5% oil),
- Thermal oils (contact for detailed information)
- Kinematic viscosity 1...400 mm²/s (contact for higher viscosities)

Materials:

Spindles	: High performance steel, hardened steel
Pump body	: Cast iron - DIN GG 26, specially heat treated
Discharge casing	: Cast iron - DIN GG 26
Housing	: Aluminium
Mechanical seal	: SiC-SiC-Viton
O-ring	: Viton
Suction pipe	: Steel

VPM 132

- * VP 132 Screw pump,
- * Electrical Motor , coupling and pump-housing.

VPC 132

- * VP 132 Screw pump,
- * Electrical Motor , coupling and pump-housing.
- * Pressure regulation valve,
- * Pressure gauge,
- * Tank lid
- * Suction and drain pipes.

VPC

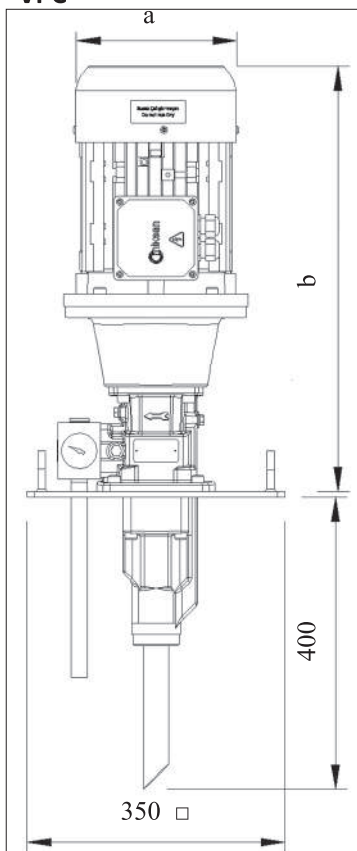

Motor

: 3-phase IE3 induction motor
2-pole, 2900 RPM;
4-pole, 1450 RPM (Optional)
Protection degree, IP 55
Insulation class F

NOMINAL SIZE

Motor		Dimensions			Cable Gland
2 Pole	4 Pole	a	b	c	
kW		mm			
1,1	0,55/0,75	157	485	105	M16x1,5
1,5	1,1	176	495	124	M20x1,5
2,2	1,5	176	520	124	M20x1,5
3	2,2/3	194	560	145	M20x1,5
4	4	194	560	145	M20x1,5
5,5	-	218	580	157	M20x1,5

* VPM and VPC series have the same hydraulic and electrical values.

PUMP PERFORMANCE AND ELECTRICAL VALUES

Type $Q_{TH}=26,7$ l/min	50 Hz	2900 RPM				Weight kg
	Max. Pressure bar	Flow Rate l/min		Motor kW		
		1 cSt	20 cSt	1 cSt	20 cSt	
VPM 132	10	23,8	26,3	1,1	1,1	32
	20	22,2	25,4	1,5	1,5	36
	30	20,9	24,3	2,2	2,2	37.5
	40	19,5	23,5	2,2	2,2	37.5
	50	18,2	22,6	3	3	43.5
	60	17,1	21,8	3	3	43.5
	70	15,9	21,2	4	4	46.5
	80	14,6	20,4	4	4	46.5
	90	13,8	20,1	5,5	5,5	53
	100	12,9	19,6	5,5	5,5	53



*Performance curves of the VP 132 series screw pumps at 2900 rpm and viscosity of 1 cSt and 20 cSt. VP 132 can also be operated at 1450 RPM.

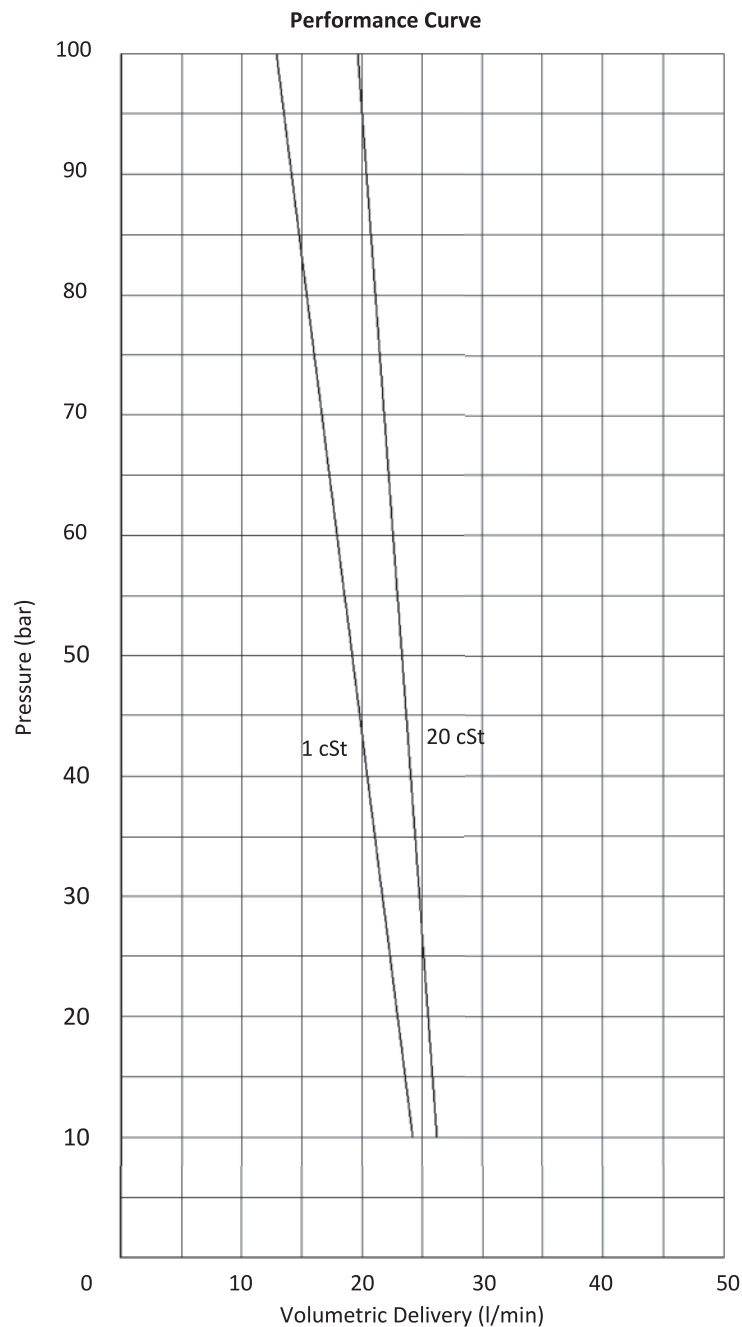

VPM

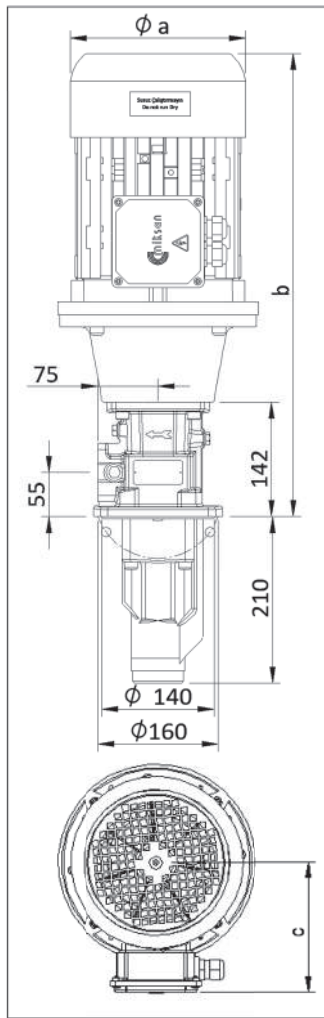

VP 140 SCREW PUMP

Applications:

- High pressure pumps with low volumetric delivery,
- Cutting, turning milling, boring, grinding and similar applications of the machine tools,
- Especially used for deep hole boring operations due to the high pressure up to 100 bar,
- Pumping cutting/cooling fluids in circulation systems,

Fluid Specifications:

- Coolants,
- Cutting oils,
- Grinding oils,
- Emulsions (minimum 5% oil),
- Thermal oils (contact for detailed information)
- Kinematic viscosity 1...400 mm²/s (contact for higher viscosities)

Materials:

Spindles	: High performance steel, hardened steel
Pump body	: Cast iron - DIN GG 26, specially heat treated
Discharge casing	: Cast iron - DIN GG 26
Housing	: Aluminium
Mechanical seal	: SiC-SiC-Viton
O-ring	: Viton
Suction pipe	: Steel

VPM 140

- * VP 140 Screw pump,
- * Electrical Motor , coupling and pump-housing.

VPC 140

- * VP 140 Screw pump,
- * Electrical Motor , coupling and pump-housing.
- * Pressure regulation valve,
- * Pressure gauge,
- * Tank lid
- * Suction and drain pipes.

VPC

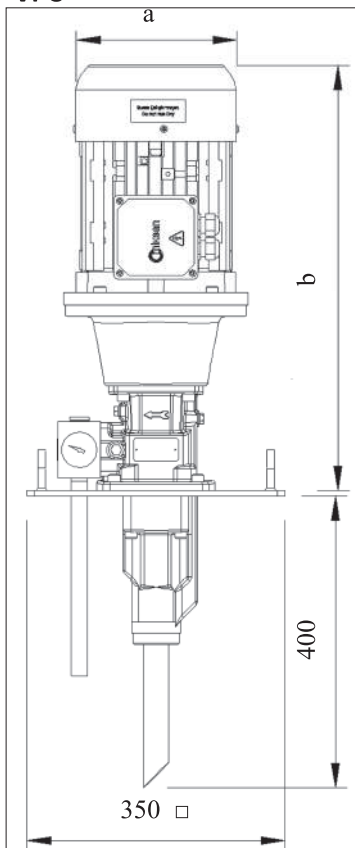

Motor

: 3-phase IE3 induction motor
 2-pole, 2900 RPM;
 4-pole, 1450 RPM (Optional)
 Protection degree, IP 55
 Insulation class F

NOMINAL SIZE

Motor		Dimensions			Cable Entry
2-Pole	4-Pole	a	b	c	
kW		mm			
1,1	0,55	157	485	105	M16x1,5
-	1,1	176	495	124	M20x1,5
2,2	1,5	176	520	124	M20x1,5
3	2,2/3	194	560	145	M20x1,5
4	4	194	580	145	M20x1,5
5,5	-	218	630	157	M20x1,5
7,5	-	258	705	198	M25x1,5

* VPM and VPC series have the same hydraulic and electrical values.

PUMP PERFORMANCE AND ELECTRICAL VALUES

Type $Q_{TH}=32,7$ l/min	50 Hz Max. Pressure bar	2900 RPM				Weight kg
		Flow Rate l/min		Motor kW		
		1 cSt	20 cSt	1 cSt	20 cSt	
VPM 140	10	30,4	32,4	1,1	1,1	32,0
	20	28,7	31,8	2,2	2,2	37,5
	30	26,9	31,2	2,2	2,2	37,5
	40	25,8	30,6	3,0	3,0	43,5
	50	23,9	30,3	4,0	4,0	46,5
	60	22,9	30	4,0	4,0	46,5
	70	21,5	29,5	5,5	5,5	53,0
	80	20,1	29	5,5	5,5	53,0
	90	18,9	28,6	7,5	7,5	74,0
	100	17,9	28,2	7,5	7,5	74,0

Performance Curve

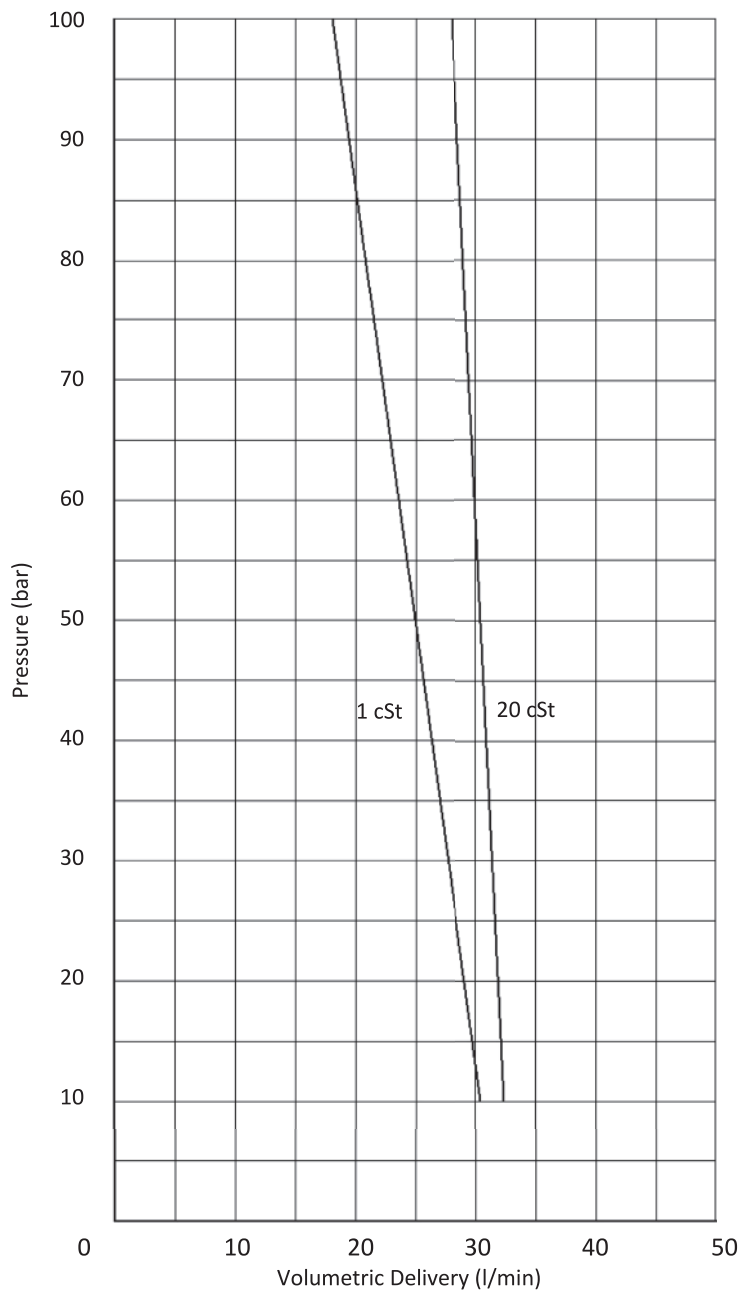

*Performance curves of the VP 140 series screw pumps at 2900 rpm and viscosity of 1 cSt and 20 cSt. VP 140 can also be operated at 1450 RPM.

VPM

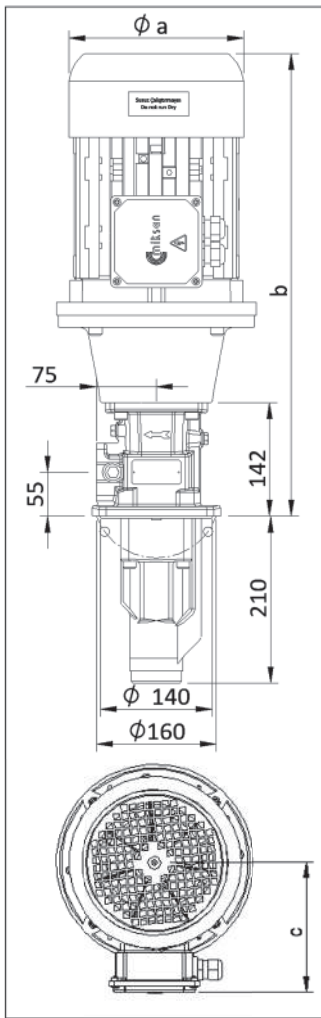

VP 150 SCREW PUMP

Applications:

- High pressure pumps with low volumetric delivery,
- Cutting, turning milling, boring, grinding and similar applications of the machine tools,
- Especially used for deep hole boring operations due to the high pressure up to 100 bar,
- Pumping cutting/cooling fluids in circulation systems,

Fluid Specifications:

- Coolants,
- Cutting oils,
- Grinding oils,
- Emulsions (minimum 5% oil),
- Thermal oils (contact for detailed information)
- Kinematic viscosity 1...400 mm²/s (contact for higher viscosities)

Materials:

- Spindles : High performance steel, hardened steel
- Pump body : Cast iron - DIN GG 26, specially heat treated
- Discharge casing : Cast iron - DIN GG 26
- Housing : Aluminium
- Mechanical seal : SiC-SiC-Viton
- O-ring : Viton
- Suction pipe : Steel

VPM 150

- * VP 150 Screw pump,
- * Electrical Motor , coupling and pump-housing.

VPC 150

- * VP 150 Screw pump,
- * Electrical Motor , coupling and pump-housing.
- * Pressure regulation valve,
- * Pressure gauge,
- * Tank lid
- * Suction and drain pipes.

VPC

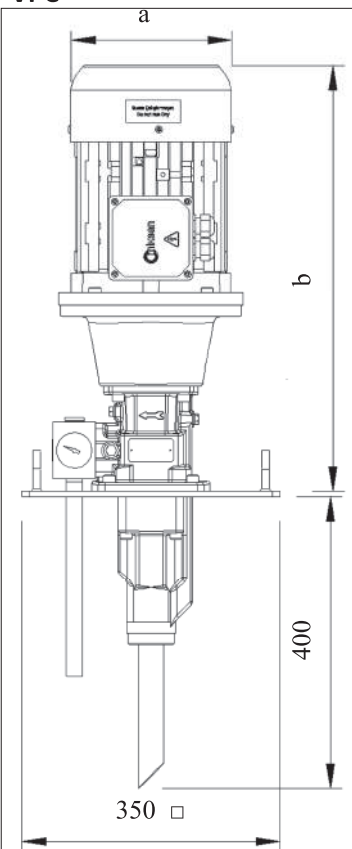

Motor

- : 3-phase IE3 induction motor
- 2-pole, 2900 RPM;
- 4-pole, 1450 RPM (Optional)
- Protection degree, IP 55
- Insulation class F

NOMINAL SIZE

Motor		Dimensions			Cable Entry
2-Pole	4-Pole	a	b	c	
kW		mm			
1,5	1,1	176	495	124	M20x1,5
2,2	1,5	176	520	124	M20x1,5
3	2,2	194	560	145	M20x1,5
4	3	194	580	145	M20x1,5
5,5	4	218	630	157	M20x1,5
7,5	5,5	258	705	198	M25x1,5

* VPM and VPC series have the same hydraulic and electrical values.

PUMP PERFORMANCE AND ELECTRICAL VALUES

Type Q _{TH} =41,3 l/min	50 Hz	2900 RPM				Weight kg
	Max. Pressure bar	Flow Rate l/min		Motor kW		
		1 cSt	20 cSt	1 cSt	20 cSt	
VPM 150	10	37,6	40,5	1,5	1,5	36,0
	20	35,4	39,6	2,2	2,2	37,5
	30	33,5	38,8	3	3	43,5
	40	31,8	38,3	4	4	46,5
	50	30,2	38	4	4	46,5
	60	28,9	37,7	5,5	5,5	53,0
	70	27,8	37,5	5,5	5,5	53,0
	80	26,2	37,2	7,5	7,5	74,0
	90	25	37	7,5	7,5	74,0
	100	23,9	36,7	7,5	7,5	74,0

Performance Curve

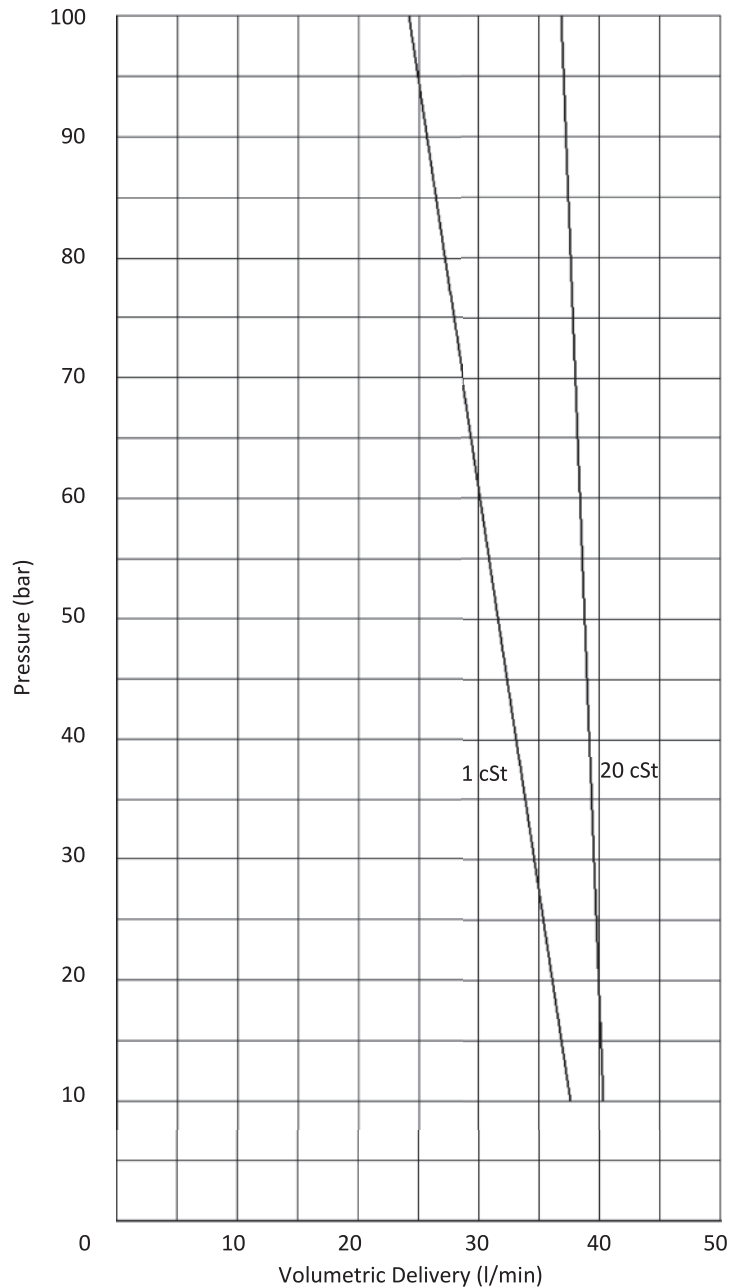

*Performance curves of the VP 150 series screw pumps at 2900 rpm and viscosity of 1 cSt and 20 cSt. VP 150 can also be operated at 1450 RPM.

VPM

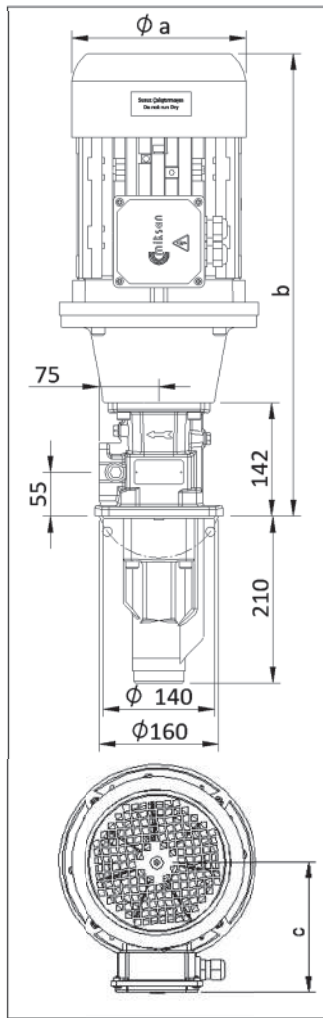

VP 160 SCREW PUMP

Applications:

- High pressure pumps with low volumetric delivery,
- Cutting, turning milling, boring, grinding and similar applications of the machine tools,
- Especially used for deep hole boring operations due to the high pressure up to 100 bar,
- Pumping cutting/cooling fluids in circulation systems,

Fluid Specifications:

- Coolants,
- Cutting oils,
- Grinding oils,
- Emulsions (minimum 5% oil),
- Thermal oils (contact for detailed information)
- Kinematic viscosity 1...400 mm²/s (contact for higher viscosities)

Materials:

- Spindles : High performance steel, hardened steel
- Pump body : Cast iron - DIN GG 26, specially heat treated
- Discharge casing : Cast iron - DIN GG 26
- Housing : Aluminium
- Mechanical sea : SiC-SiC-Viton
- O-ring : Viton
- Suction pipe : Steel

VPM 160

- * VP 160 Screw pump,
- * Electrical Motor , coupling and pump-housing.

VPC 160

- * VP 160 Screw pump,
- * Electrical Motor , coupling and pump-housing.
- * Pressure regulation valve,
- * Pressure gauge,
- * Tank lid
- * Suction and drain pipes.

VPC

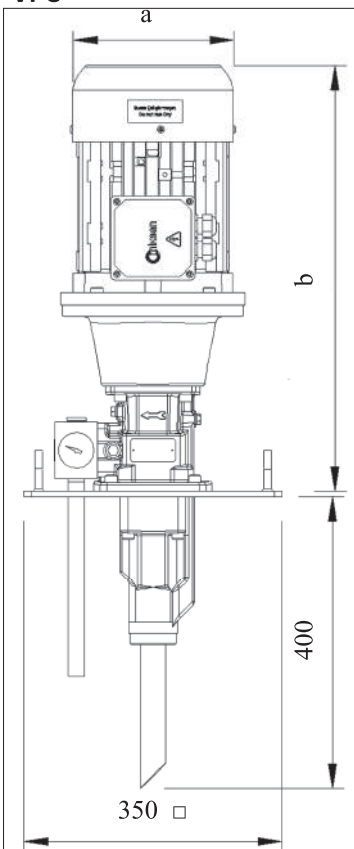

Motor

- : 3-phase IE3 induction motor
- 2-pole, 2900 RPM;
- 4-pole, 1450 RPM (Optional)
- Protection degree, IP 55
- Insulation class F

NOMINAL SIZE

Motor		Dimensions			Cable Entry
2-Pole	4-Pole	a	b	c	
kW		mm			
1,5	1,1	176	495	124	M20x1,5
2,2	-	176	520	124	M20x1,5
3	2,2	194	560	145	M20x1,5
4	3	218	580	157	M20x1,5
5,5	4	258	630	198	M20x1,5
7,5	5,5	258	705	198	M25x1,5
11	-	258	705	198	M25x1,5

* VPM and VPC series have the same hydraulic and electrical values.

PUMP PERFORMANCE AND ELECTRICAL VALUES

Type Q _{TH} =49,2 l/min	50 Hz	2900 RPM				Weight kg
	Max. Pressure bar	Flow Rate l/min		Motor kW		
		1 cSt	20 cSt	1 cSt	20 cSt	
VPM 160	10	45,5	47,6	1,5	1,5	36,0
	20	43,9	44,5	2,2	2,2	37,5
	30	41,2	42,7	3	3	43,5
	40	39,6	41,6	4	4	46,5
	50	38,1	41	5,5	5,5	53,0
	60	36	40,5	5,5	5,5	53,0
	70	34,5	40,2	7,5	7,5	74,0
	80	33,4	39,8	7,5	7,5	74,0
	90	31,9	39,5	11	11	81,0
	100	31,3	39,2	11	11	81,0

Performance Curve

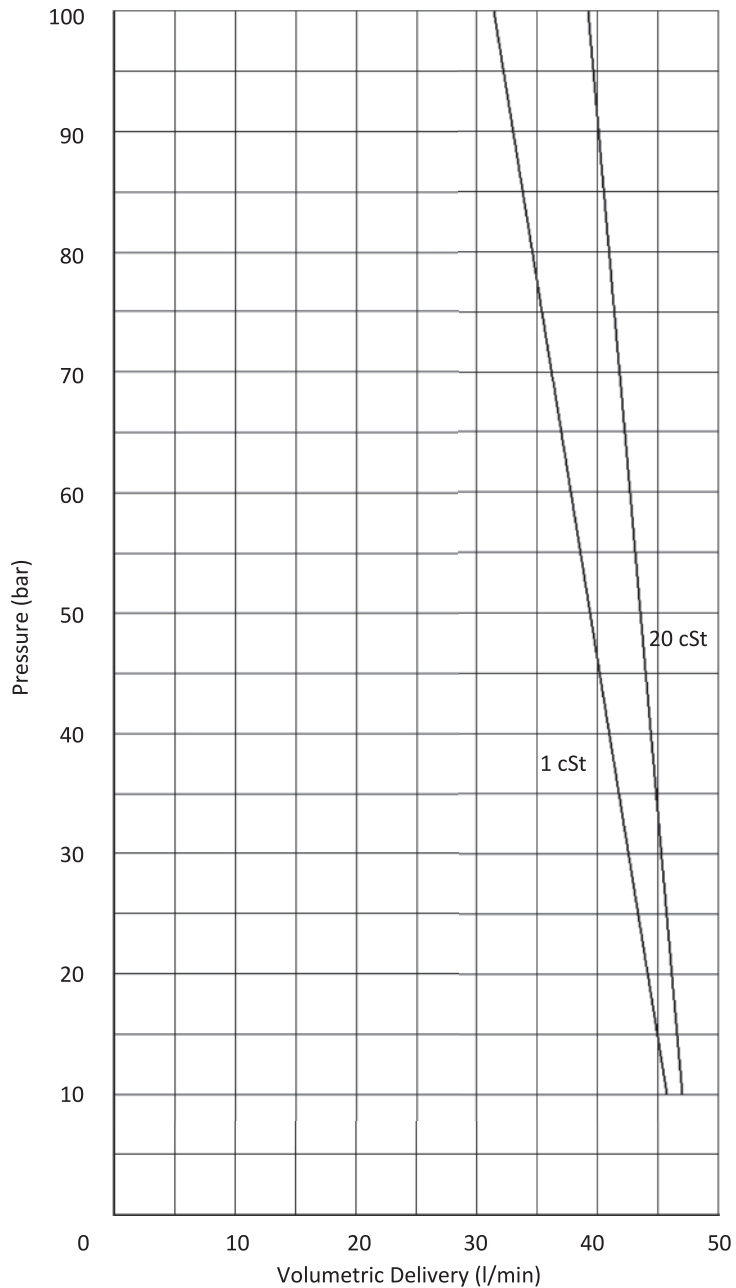

*Performance curves of the VP 160 series screw pumps at 2900 rpm and viscosity of 1 cSt and 20 cSt. VP 160 can also be operated at 1450 RPM.

VPM

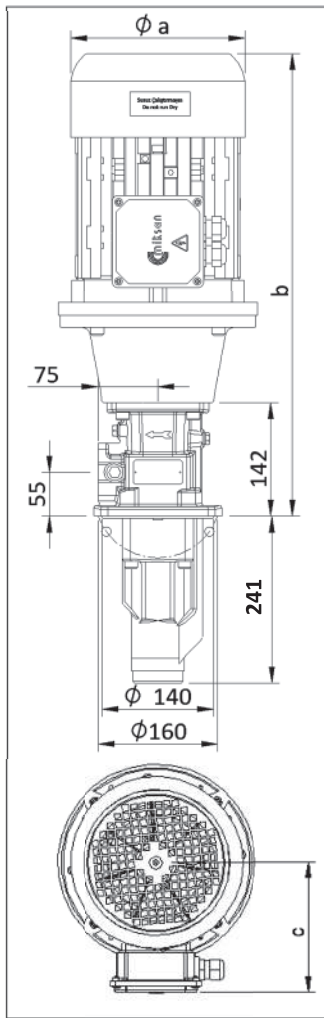

VPC

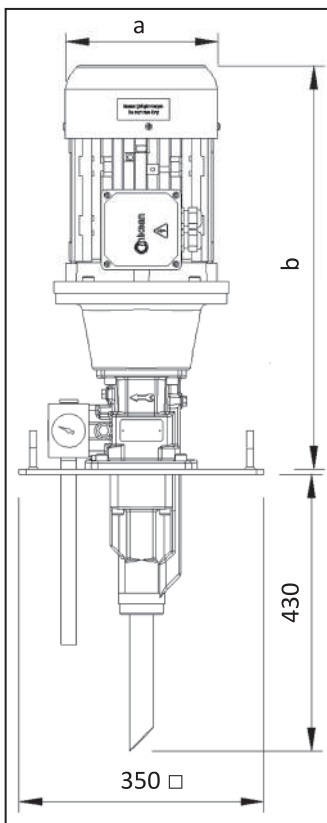

VP 248 SCREW PUMP

Applications:

- High pressure pumps with low volumetric delivery,
- Cutting, turning milling, boring, grinding and similar applications of the machine tools,
- Especially used for deep hole boring operations due to the high pressure up to 100 bar,
- Pumping cutting/cooling fluids in circulation systems,

Fluid Specifications:

- Coolants,
- Cutting oils,
- Grinding oils,
- Emulsions (minimum 5% oil),
- Thermal oils (contact for detailed information)
- Kinematic viscosity 1...400 mm²/s (contact for higher viscosities)

Materials:

- Spindles : High performance steel, hardened steel
- Pump body : Cast iron - DIN GG 26, specially heat treated
- Discharge casing : Cast iron - DIN GG 26
- Housing : Aluminium
- Mechanical sea : SiC-SiC-Viton
- O-ring : Viton
- Suction pipe : Steel

VPM 248

- * VP 248 Screw pump,
- * Electrical Motor , coupling and pump-housing.

VPC 248

- * VP 248 Screw pump,
- * Electrical Motor , coupling and pump-housing.
- * Pressure regulation valve,
- * Pressure gauge,
- * Tank lid
- * Suction and drain pipes.

Motor

- : 3-phase IE3 induction motor
- 2-pole, 2900 RPM;
- 4-pole, 1450 RPM (Optional)
- Protection degree, IP 55
- Insulation class F

NOMINAL SIZE

Motor		Dimensions			Cable Entry
2-Pole	4-Pole	a	b	c	
kW		mm			
1,5	1,1	176	495	124	M20x1,5
2,2	-	176	520	124	M20x1,5
3	2,2	194	560	145	M20x1,5
4	3	218	580	157	M20x1,5
5,5	4	258	630	198	M20x1,5
7,5	5,5	258	705	198	M25x1,5
11	-	258	705	198	M25x1,5

* VPM and VPC series have the same hydraulic and electrical values.

PUMP PERFORMANCE AND ELECTRICAL VALUES

Type Q _{TH} =64,2 l/min	50 Hz	2900 RPM				Weight kg
	Max. Pressure bar	Flow Rate l/min		Motor kW		
		1 cSt	20 cSt	1 cSt	20 cSt	
VPM 248	10	61,5	63,3	2,2	2,2	40,5
	20	58,5	62,1	3	3	46,5
	30	56,5	60,8	4	4	49,5
	40	54,1	60,2	5,5	5,5	56,0
	50	52,5	59,8	7,5	7,5	77,0
	60	50,6	59,5	7,5	7,5	77,0
	70	48,7	59	11	11	84,0
	80	47	58,6	11	11	84,0
	90	44,7	58,5	11	11	84,0
	100	43,3	58,3	15	15	98,0



*Performance curves of the VP 248 series screw pumps at 2900 rpm and viscosity of 1 cSt and 20 cSt. VP 248 can also be operated at 1450 RPM.

Performance Curve

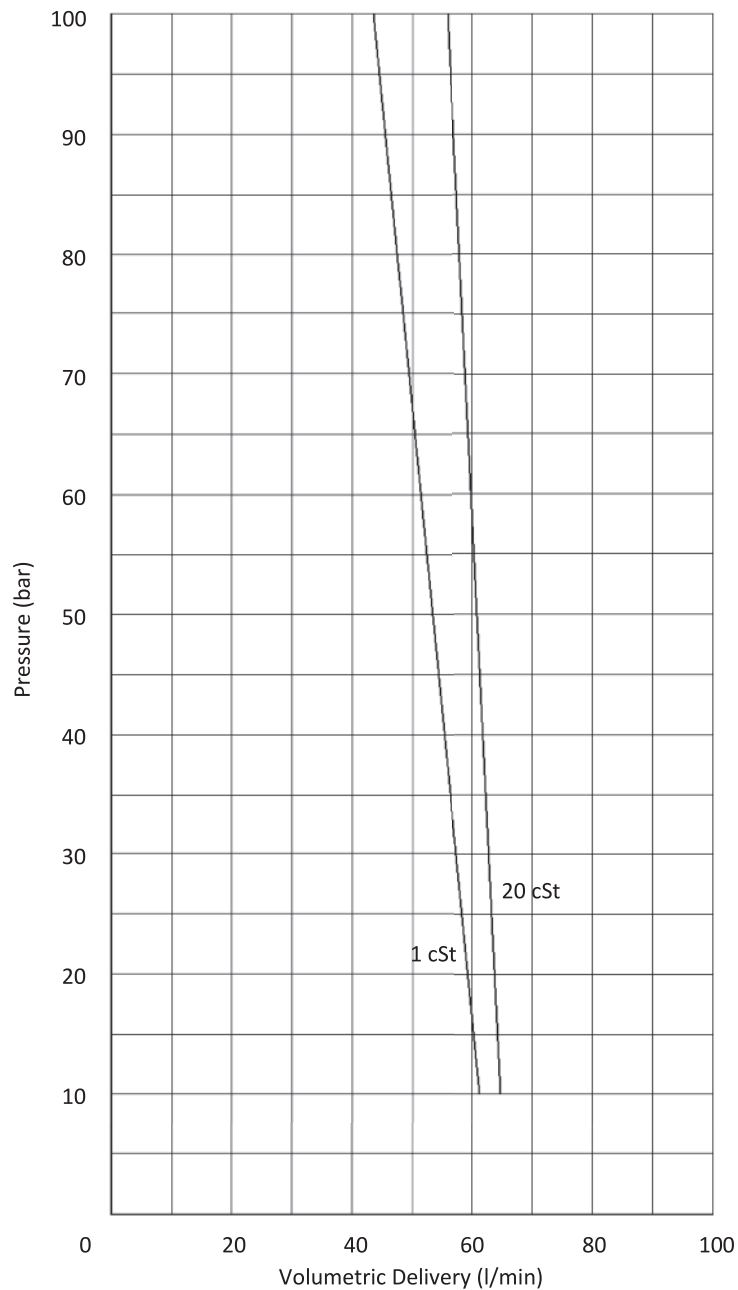

VPM

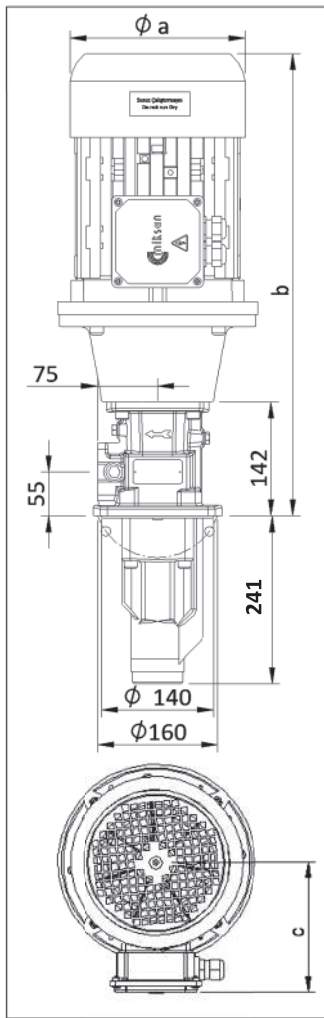

VP 262 SCREW PUMP

Applications:

- High pressure pumps with low volumetric delivery,
- Cutting, turning milling, boring, grinding and similar applications of the machine tools,
- Especially used for deep hole boring operations due to the high pressure up to 100 bar,
- Pumping cutting/cooling fluids in circulation systems,

Fluid Specifications:

- Coolants,
- Cutting oils,
- Grinding oils,
- Emulsions (minimum 5% oil),
- Thermal oils (contact for detailed information)
- Kinematic viscosity 1...400 mm²/s (contact for higher viscosities)

Materials:

Spindles	: High performance steel, hardened steel
Pump body	: Cast iron - DIN GG 26, specially heat treated
Discharge casing	: Cast iron - DIN GG 26
Housing	: Aluminium
Mechanical sea	: SiC-SiC-Viton
O-ring	: Viton
Suction pipe	: Steel

VPM 262

- * VP 262 Screw pump,
- * Electrical Motor , coupling and pump-housing.

VPC 262

- * VP 262 Screw pump,
- * Electrical Motor , coupling and pump-housing.
- * Pressure regulation valve,
- * Pressure gauge,
- * Tank lid
- * Suction and drain pipes.

VPC

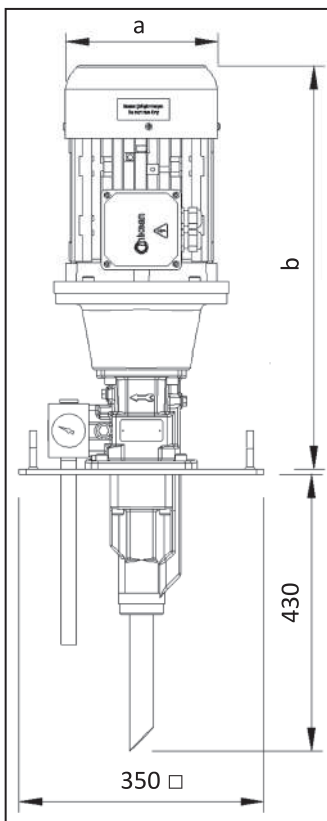

Motor

: 3-phase IE3 induction motor
 2-pole, 2900 RPM;
 4-pole, 1450 RPM (Optional)
 Protection degree, IP 55
 Insulation class F

NOMINAL SIZE

Motor		Dimensions			Cable Entry
2-Pole	4-Pole	a	b	c	
kW		mm			
1,5	1,1	176	495	124	M20x1,5
2,2	-	176	520	124	M20x1,5
3	2,2	194	560	145	M20x1,5
4	3	218	580	157	M20x1,5
5,5	4	258	630	198	M20x1,5
7,5	5,5	258	705	198	M25x1,5
11	-	258	705	198	M25x1,5

* VPM and VPC series have the same hydraulic and electrical values.

PUMP PERFORMANCE AND ELECTRICAL VALUES

Type Q _{TH} =83,1 l/min	50 Hz	2900 RPM				Weight kg
	Max. Pressure bar	Flow Rate l/min		Motor kW		
		1 cSt	20 cSt	1 cSt	20 cSt	
VPM 262	10	79,7	82,6	2,2	2,2	40,5
	20	76,5	80,9	4	4	46,5
	30	73,9	80,1	5,5	5,5	56,0
	40	71,1	79,4	7,5	7,5	77,0
	50	69	78,3	11	11	84,0
	60	66,5	77,3	11	11	84,0
	70	64,6	76,9	11	11	84,0
	80	62,5	76,1	15	15	98,0
	90	60,4	75,5	15	15	98,0
	100	59,2	74,9	18,5	18,5	105,0



Performance Curve

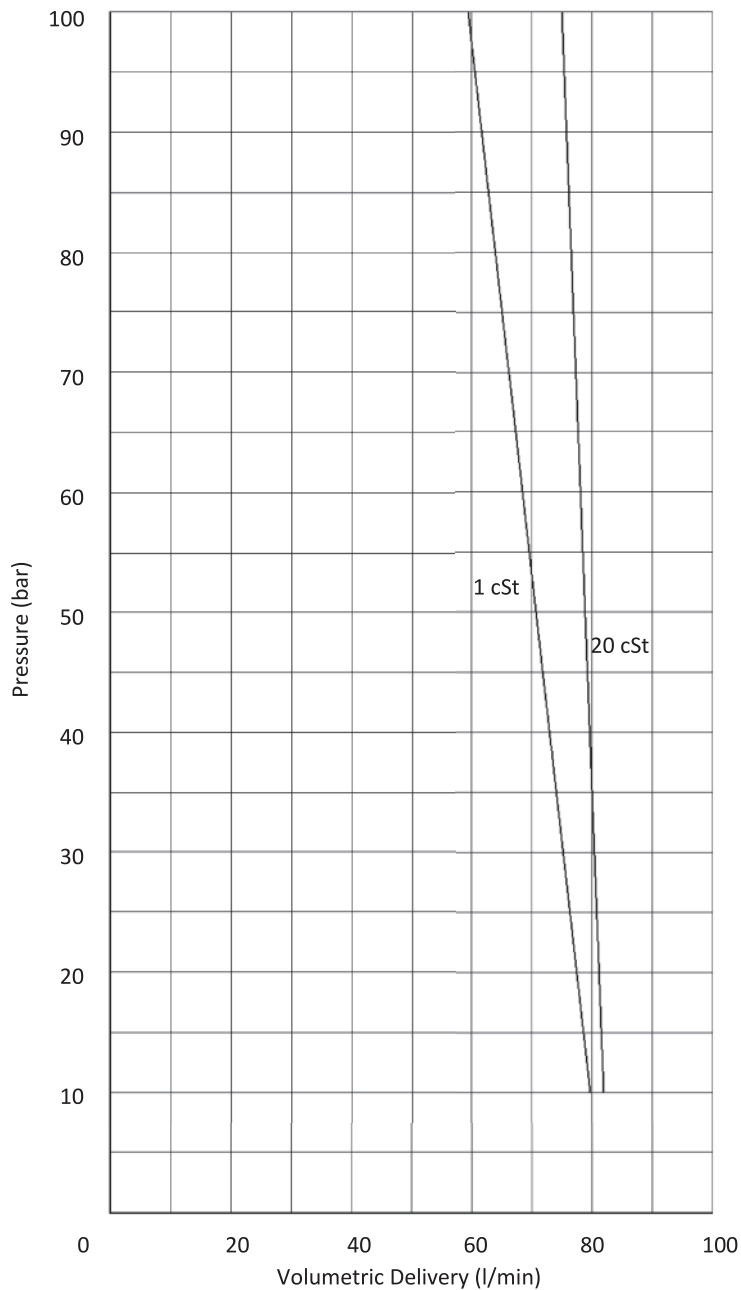

*Performance curves of the VP 260 series screw pumps at 2900 rpm and viscosity of 1 cSt and 20 cSt. VP 260 can also be operated at 1450 RPM.

VPM

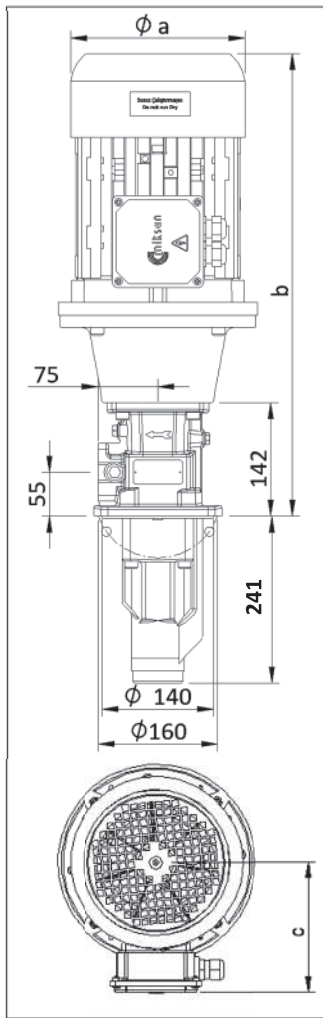

VPC

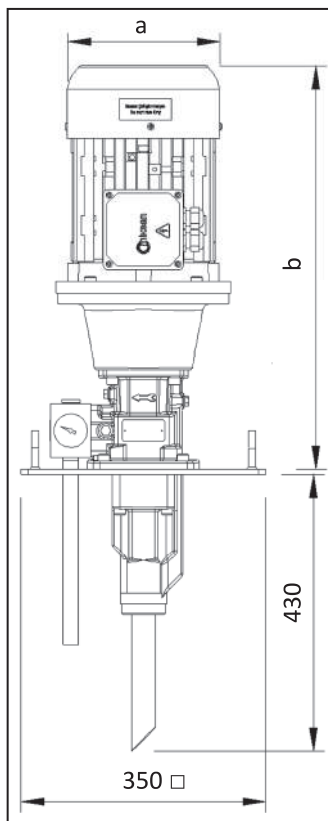

VP 272 SCREW PUMP

Applications:

- High pressure pumps with low volumetric delivery,
- Cutting, turning milling, boring, grinding and similar applications of the machine tools,
- Especially used for deep hole boring operations due to the high pressure up to 100 bar,
- Pumping cutting/cooling fluids in circulation systems,

Fluid Specifications:

- Coolants,
- Cutting oils,
- Grinding oils,
- Emulsions (minimum 5% oil),
- Thermal oils (contact for detailed information)
- Kinematic viscosity 1...400 mm²/s (contact for higher viscosities)

Materials:

- Spindles : High performance steel, hardened steel
- Pump body : Cast iron - DIN GG 26, specially heat treated
- Discharge casing : Cast iron - DIN GG 26
- Housing : Aluminium
- Mechanical sea : SiC-SiC-Viton
- O-ring : Viton
- Suction pipe : Steel

VPM 272

- * VP 272 Screw pump,
- * Electrical Motor , coupling and pump-housing.

VPC 272

- * VP 272 Screw pump,
- * Electrical Motor , coupling and pump-housing.
- * Pressure regulation valve,
- * Pressure gauge,
- * Tank lid
- * Suction and drain pipes.

Motor

- : 3-phase IE3 induction motor
- 2-pole, 2900 RPM;
- 4-pole, 1450 RPM (Optional)
- Protection degree, IP 55
- Insulation class F

NOMINAL SIZE

Motor		Dimensions			Cable Entry
2-Pole	4-Pole	a	b	c	
kW		mm			
1,5	1,1	176	495	124	M20x1,5
2,2	-	176	520	124	M20x1,5
3	2,2	194	560	145	M20x1,5
4	3	218	580	157	M20x1,5
5,5	4	258	630	198	M20x1,5
7,5	5,5	258	705	198	M25x1,5
11	-	258	705	198	M25x1,5

* VPM and VPC series have the same hydraulic and electrical values.

PUMP PERFORMANCE AND ELECTRICAL VALUES

Type Q _{TH} =96,3 l/min	50 Hz	2900 RPM				Weight kg
	Max. Pressure bar	Flow Rate l/min		Motor kW		
		1 cSt	20 cSt	1 cSt	20 cSt	
VPM 272	10	90	93,1	2,2	2,2	40,5
	20	86	90,2	4	4	46,5
	30	82,3	88,9	5,5	5,5	56,0
	40	79	88	7,5	7,5	77,0
	50	76,2	87	11	11	84,0
	60	73,5	86,1	11	11	84,0
	70	71	85,3	15	15	98,0
	80	67,6	84,2	15	15	98,0
	90	65,4	83,5	18,5	18,5	105,0
	100	63,3	82,8	22	22	117,0



Performance Curve

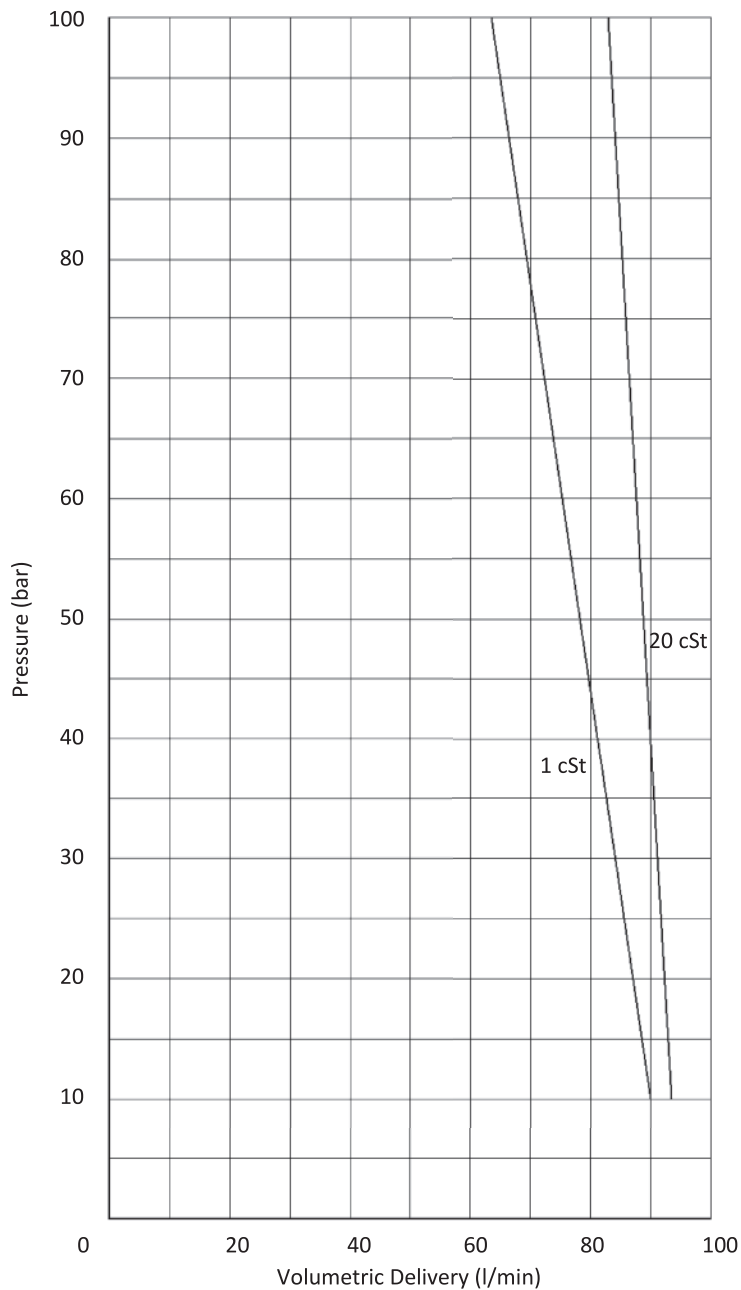

*Performance curves of the VP 272 series screw pumps at 2900 rpm and viscosity of 1 cSt and 20 cSt. VP 272 can also be operated at 1450 RPM.

Unit Conversion Tables

Volumetric Delivery (Q)	L / min	L / s	m ³ / s	m ³ / h	GPM (USA)	GPM (UK)
1 l / min	x	0.0167	1.6667e-5	0.06	0.264	0.22
1 l / s	60	x	0.001	3.6	15.85	13.2
1 m ³ / s	60000	1000	x	3600	15850.32	13198.18
1 m ³ / h	16.667	0.278	2.78e-4	x	4.403	3.666
1 GPM (USA)	3.785	0.063	6.3e-5	0.227	x	0.833
1 GPM (UK)	4.546	0.0758	7.5768e-5	0.2728	1.201	x

Delivery Head (H _m)	mwc	Bar	MPa	feet
1 mwc	x	0.09807	0.009807	3.2808
1 bar	10.2	x	0.1	33.4553
1 MPa	101.97	10	x	334.553
1 feet	0.3048	0.02989	0.002989	x

Power (P)	kW	HP
1 kW	x	1.341
1 HP	0.746	x

* We reserve the right to change dimensions and terms without notice.



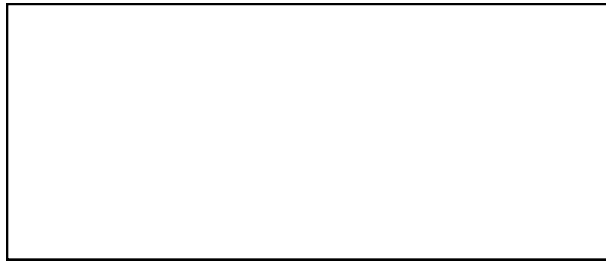

MİKSAN MOTOR SAN. VE TİC. A.Ş.
B.O.S.B. Bakır ve Pirinç Sanayicileri Sitesi
Menekşe Cad. No:1 Beylikdüzü - İstanbul / TÜRKİYE
Tel: +90 212 284 64 00
Fax: +90 212 279 55 67
e-mail: info@miksanmotor.com
web: www.miksanmotor.com